

# ***Ditch Witch***<sup>®</sup>

## **JT2720 Mach 1 All Terrain**

ISSUE NO. 12PL-07/11

For Replacement Copy Order **P/N 053-081**

**This product is covered by one or more of the following patents:**

**US** B1 4,858,704; 4,953,638; 5,148,880; 5,242,026; 5,341,887; 5,490,569; 5,684,466; 5,713,423, 5,794,719; 5,880,680; 5,941,322; 6,085,852; 6,109,371; 6,179,065; 6,216,803; 6,250,403; 6,250,404; 6,290,606; 6,311,790; 6,411,094; 6,543,551; 6,550,547; 6,672,409; 6,739,413; 6,776,246; 6,808,210; 6,827,158; RE37,450; RE37,923; RE37,975; RE38,418

**AU** 689,533; 706,544; 718,034, 755,862

**CA** 2,156,398

**FR** 674,093

**DE** 694 17 019; 695 29 634; 297 01 406

**EP** 0683845; 0674093; 0817901; 0846841

**GB** 2,209,239; 2,312,006; EP674,093; EP846,841

**JP** 3,458,247

**Other U.S. and foreign patents pending**

This manual contains information concerning the following models:  
**JT2720 Mach 1 All Terrain Directional Drilling System**

Copyright 2004, 2005, 2006, 2007, 2008, 2011 by The Charles Machine Works, Inc.



**Ditch Witch**, Ditch Witch, CMW, AutoCrowd, Jet Trac, Roto Witch, Subsite, Fluid Miser, Power Pipe, Super Witch, Pierce Arrow, The Underground, The Underground Authority Worldwide, and Zahn are registered trademarks of The Charles Machine Works, Inc.

ID0134854



# FOREWORD

---

This manual contains illustrated parts lists to help you select quality ProTech<sup>®</sup> Replacement parts for your Ditch Witch<sup>®</sup> equipment. Using other replacement parts will lessen the productivity of your equipment.

- ◆ Part numbers enclosed in a box are no longer available from The Charles Machine Works, Inc. Your local Ditch Witch dealer may be able to locate the part for you.
- ◆ Footnotes provide more information to help you identify parts shown in the manual.
- ◆ Assembly instructions and Tech Bits articles referenced in footnotes are available through your local Ditch Witch dealer.
- ◆ Description and specifications in this book were current at publication. However, The Charles Machine Works, Inc. reserves the right to improve equipment, so this manual might not reflect the most current improvements.
- ◆ Instructions on recommended equipment use and maintenance are in the Operator's Manual that was shipped with your equipment.

**Keep the following in mind when ordering ProTech replacement parts:**

- ◆ Specify parts you need by part number and description, not by illustration reference numbers.
- ◆ Have equipment model and serial number on hand to help ensure you get the right parts for your machine whether it's old or new.

**Thank you for buying and using Ditch Witch equipment and ProTech replacement parts.**

# WARRANTY

---

DW WARRANTY Policy  
July, 2005

## **POLICY 1: DITCH WITCH® EQUIPMENT AND REPLACEMENT PARTS LIMITED WARRANTY POLICY**

Subject to the limitation and exclusions herein, free replacement parts will be provided at any authorized Ditch Witch dealership for any Ditch Witch equipment or parts manufactured by The Charles Machine Works, Inc. (CMW) that fail due to a defect in material or workmanship within one (1) year of first commercial use (Exception: 2 years for all SK500 Attachments). Free labor will be provided at any authorized Ditch Witch dealership for installation of parts under this warranty during the first year following "initial commercial" use of the serial numbered Ditch Witch equipment on which it is installed. The customer is responsible for transporting their equipment to an authorized Ditch Witch dealership for all warranty work.

### **EXCLUSIONS FROM PRODUCT WARRANTY**

- All incidental or consequential damages.
- All defects, damages, or injuries caused by misuse, abuse, improper installation, alteration, neglect, or uses other than those for which products were intended.
- All defects, damages, or injuries caused by improper training, operation, or servicing of products in a manner inconsistent with manufacturer's recommendations.
- All engines and engine accessories (these are covered by original manufacturer's warranty).
- Tires, belts, and other parts which are subject to another manufacturer's warranty. (Such warranty will be available to purchaser.)
- ALL IMPLIED WARRANTIES NOT EXPRESSLY STATED HEREIN, INCLUDING ANY WARRANTY OF FITNESS FOR A PARTICULAR PURPOSE AND MERCHANTABILITY.

IF THE PRODUCTS ARE PURCHASED FOR COMMERCIAL PURPOSES, AS DEFINED BY THE UNIFORM COMMERCIAL CODE, THEN THERE ARE NO WARRANTIES WHICH EXTEND BEYOND THE FACE HEREOF AND THERE ARE NO IMPLIED WARRANTIES OF ANY KIND WHICH EXTEND TO A COMMERCIAL BUYER. ALL OTHER PROVISIONS OF THIS LIMITED WARRANTY APPLY INCLUDING THE DUTIES IMPOSED.

Ditch Witch products have been tested to deliver acceptable performance in most conditions. This does not imply they will deliver acceptable performance in all conditions. Therefore, to assure suitability, products should be operated under anticipated working conditions prior to purchase.

Defects will be determined by an inspection within thirty (30) days of the date of failure of the product or part by CMW or its authorized dealer. CMW will provide the location of its inspection facilities or it's nearest authorized dealer upon inquiry. CMW reserves the right to supply remanufactured replacement parts under this warranty as it deems appropriate.

Extended warranties are available upon request from your local Ditch Witch dealer or CMW.

Some states do not allow exclusion or limitation of incidental or consequential damages, so the above limitation or exclusion may not apply. Further, some states do not allow exclusion of or limitation of how long an implied warranty lasts, so the above limitation may not apply. This limited warranty gives product owner specific legal rights and the product owner may also have other rights which vary from state to state.

For information regarding this limited warranty, contact CMW's Product Support Department, P.O. Box 66, Perry, OK 73077-0066, or contact your local Ditch Witch dealer.



# CONTENTS

---

## Decals

Decal Location - AT/JT2720 Mach 1 .....	8
---	---

## Engine Components

Air Filter System .....	26
Cold Start Kit .....	30
Coolant System .....	24
Engine .....	16
Engine Oil Drain - Remote .....	28
Fan Clutch .....	22
Radiator - Begins .....	20
Radiator - Ends .....	18

## Frame Components

Battery Support .....	120
Carriage - All Terrain .....	48
Carriage - JT2720 Mach 1 .....	46
Carriage Chain .....	40
Clamp Assembly .....	76
Coolant System Mounting - Begins .....	110
Covers .....	106
Cylinder Grease .....	96
Front Guide/Wiper .....	82
Front Sprocket .....	44
Fuel Tank .....	108
Gearbox - Rotation - All Terrain - Begins .....	72
Gearbox - Rotation - All Terrain - Ends .....	68
Gearbox - Rotation - Mach 1 - Begins .....	64
Gearbox - Rotation - Mach 1 - Ends .....	60
Gearbox - Track Drive - Plntry .....	88
Ground Drive Brake .....	90
Hoods .....	98
Hose Track - All Terrain .....	38
Hose Track - JT2720 Mach 1 .....	36
Idler - Front .....	92
Idler - Roller .....	94
Internal Water Swivel - All Terrain - Begins .....	52
Pivot .....	34
Relay Panel - All Terrain .....	118
Relay Panel - JT2720 Mach 1 .....	116
Side Panels .....	100
Sound Insulation - Cover .....	112
Sound Insulation - Lower .....	104
Sound Insulation - Upper .....	102
Spindle Drive - All Terrain - Begins .....	54
Spindle Drive - All Terrain - Ends .....	50
Spindle Drive - JT2720 Mach 1 - Begins .....	58
Spindle Drive - JT2720 Mach 1 - Ends .....	56
Stabilizer - Rear .....	84
Thrust Drive .....	42
Track Group .....	86
Wrench - Pipe Guide .....	80

## Operator's Station

Console - Aux. - All Terrain - Begins .....	142
Console - Auxiliary - All Terrain .....	140
Console - Auxiliary - Mach 1 .....	138
Console - Right Electrical .....	136
Dual Axis Joystick .....	134
Operator's Station Gauges .....	130
Seat Mount .....	126
Step .....	124
Tool Box Gauges .....	144

## Hydraulics

Auxiliary Pressure Hydraulics .....	172
Auxiliary Pump Inlet Hydraulics .....	170
Brake Line .....	198
Charge Filter/Shifting Solenoid .....	168
Console Hydraulics - Right .....	208
Cooler Hydraulics .....	166
Drill Frame Pivot Hydraulics .....	224
Ground Drive Control Hydraulics .....	196
Hydraulic Cylinder (2x1) .....	226
Hydraulic Cylinder (2x1.25) .....	228
Hydraulic Cylinder (4x2) .....	230
Hydraulic Cylinder (4.5x2.25x2.75) .....	232
Hydraulic Diagram - All Terrain .....	158
Hydraulic Diagram - JT2720 Mach 1 .....	156
Hydraulic Pumps .....	160
Hydraulic Reservoir - Begins .....	164
Hydraulic Schematic - All Terrain .....	152
Hydraulic Schematic - Mach 1 .....	148
Load Sense Hydraulics .....	200
Load Sense Pressure Hydraulics .....	202
Load Sense Pump/Case Drain .....	204
Load Sense Return Hydraulics .....	206
Pipe Gripper Hydraulics .....	218
Pipe Gripper Hydraulics - Begins .....	220
Pump Inlet .....	162
Rotation Brake Hydraulics .....	194
Rotation Hydraulics - Inner .....	184
Rotation Hydraulics - Outer - All Terrain .....	188
Rotation Hydraulics - Outer - Mach 1 .....	186
Rotation Motor Hot Oil - All Terrain .....	192
Rotation Motor Hot Oil - Mach 1 .....	190
Rotation Pressure Gauge .....	180
Rotation Pressure Gauge - Inner .....	182
Stabilizer Hydraulics .....	222
Thrust Drive Hydraulics .....	178
Thrust Limiter .....	176
Thrust Pressure Gauge .....	174
Wrench - Front Hydraulics .....	212
Wrench - Front Pressure/Return Hydraulics .....	210
Wrench - Rear .....	214
Wrench - Rotation Hydraulics .....	216

**Continued**

# CONTENTS

---

## **Electrical**

Coil Mount .....	270
Electric Diagram - Console .....	254
Electric Diagram - Engine .....	250
Electric Diagram - Fan Clutch.....	246
Electric Diagram - Gauge - All Terrain .....	260
Electric Diagram - Gauge - JT .....	262
Electric Diagram - Inner Rotation - Begins .....	248
Electric Diagram - Vice Wrench .....	264
Electric Diagram - Voltage Translator - Begins .....	244
Electric Diagram - Work Light .....	266
Electric Schematic .....	236
Electric Strike System .....	272
Ground Drive Control .....	274
Grounding Hardware - ESS .....	268

## **Anchor Systems**

Anchor .....	286
Anchor Motor Hydraulics - Left .....	290
Anchor Motor Hydraulics - Right .....	292
Anchor Pivot Frame .....	278
Anchor Thrust Cylinder - Left .....	294
Anchor Thrust Cylinder - Right .....	296
Anchor Valve Pressure/Return Hydraulics .....	288
Auger Anchor Drive - Left .....	280
Auger Anchor Drive - Right .....	282
Flange Hex Driver .....	284
Hydraulic Cylinder (2"x1.25"x24") .....	298

## **Fluid System**

Internal Water Swivel - All Terrain - Ends .....	312
Mud Pressure Hydraulics .....	304
Mud Pump - Begins .....	310
Mud Pump - Ends .....	308
Mud Pump Hydraulics .....	306
Mud Pump Inlet/Wash Wand Connection .....	314
Mud Pump/Antifreeze Kit - Begins .....	302
Wash Wand .....	316

## **Pipe Loader System**

Applicator .....	330
Auto-Luber Assembly .....	326
Auxiliary Valve/Pipe Lift Hydraulics .....	364
Electric Diagram - Pipe Loader .....	370
Grease Pump .....	328
Grease Pump - Mounting .....	320
Greaser Hydraulics .....	322
Pipe Loader .....	336
Pipe Loader - Cover .....	354
Pipe Loader - Mount .....	334
Pipe Loader Lifters .....	356
Pipe Shuttle - Front .....	342
Pipe Shuttle - Front - Begins .....	344
Pipe Shuttle - Rear .....	350
Pipe Shuttle - Rear - Begins .....	352

Proximity Switch .....	368
Selector Valve .....	324
Shuttle Guard Mount .....	332
Shuttle Motor Case Drain .....	362
Shuttle Motor Hydraulics .....	360
Shuttle Mount - Front .....	338
Shuttle Mount - Front - Begins .....	340
Shuttle Mount - Rear .....	346
Shuttle Mount - Rear - Begins .....	348
Shuttle Stop .....	358
Shuttle Stop Hydraulics .....	366

## **Accessories**

Drilling Fluid Transfer .....	386
Heated Hose Kit .....	384
Mud Mixing Accessories .....	378
Pipe Box - All Terrain .....	392
Pipe Box - All Terrain - Ends .....	388
Pipe Box - Mach 1 .....	390
Pipe Box - Mach 1 - Ends .....	394
Wire Line Assembly .....	380
Work Lights .....	382

## **Miscellaneous**

Bolt/Nut Torque Chart .....	398
Filters .....	402
Optional Kits .....	402
Parts Manual Change Request .....	403
Related Publications .....	402
Replacement O-Ring Chart.....	401
Warranty Registration .....	406

# DECALS

# DECAL LOCATION

JT2720 MACH 1  
JT2720 ALL TERRAIN

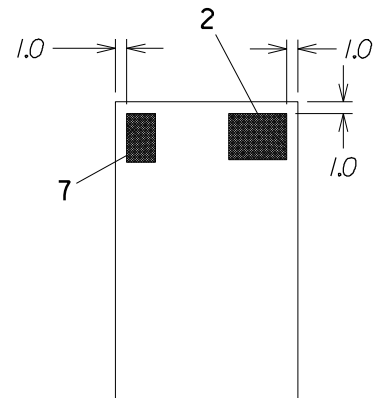
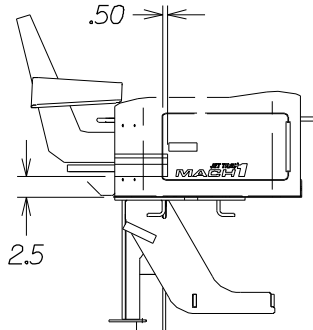
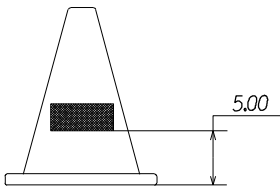
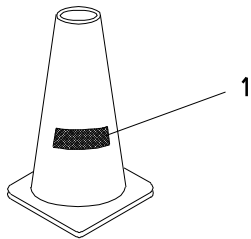
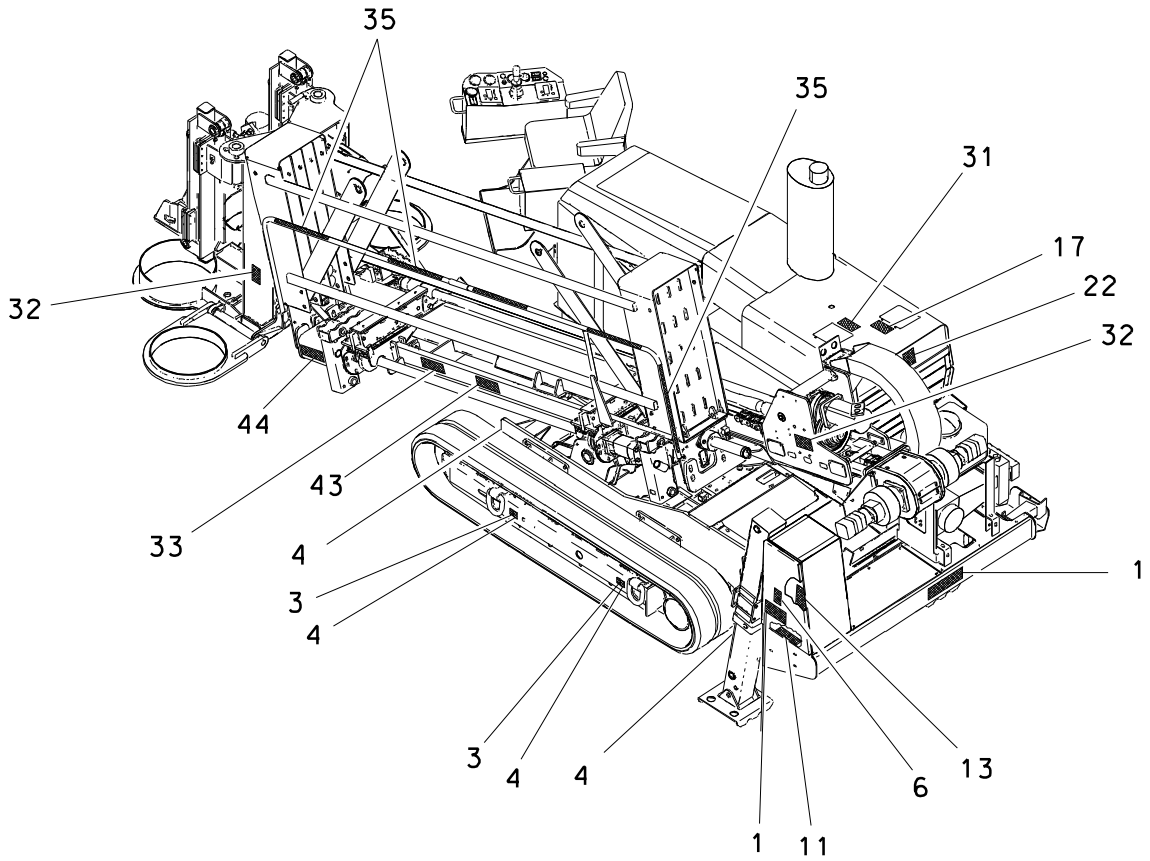

# DECAL LOCATION

JT2720 MACH 1  
JT2720 ALL TERRAIN

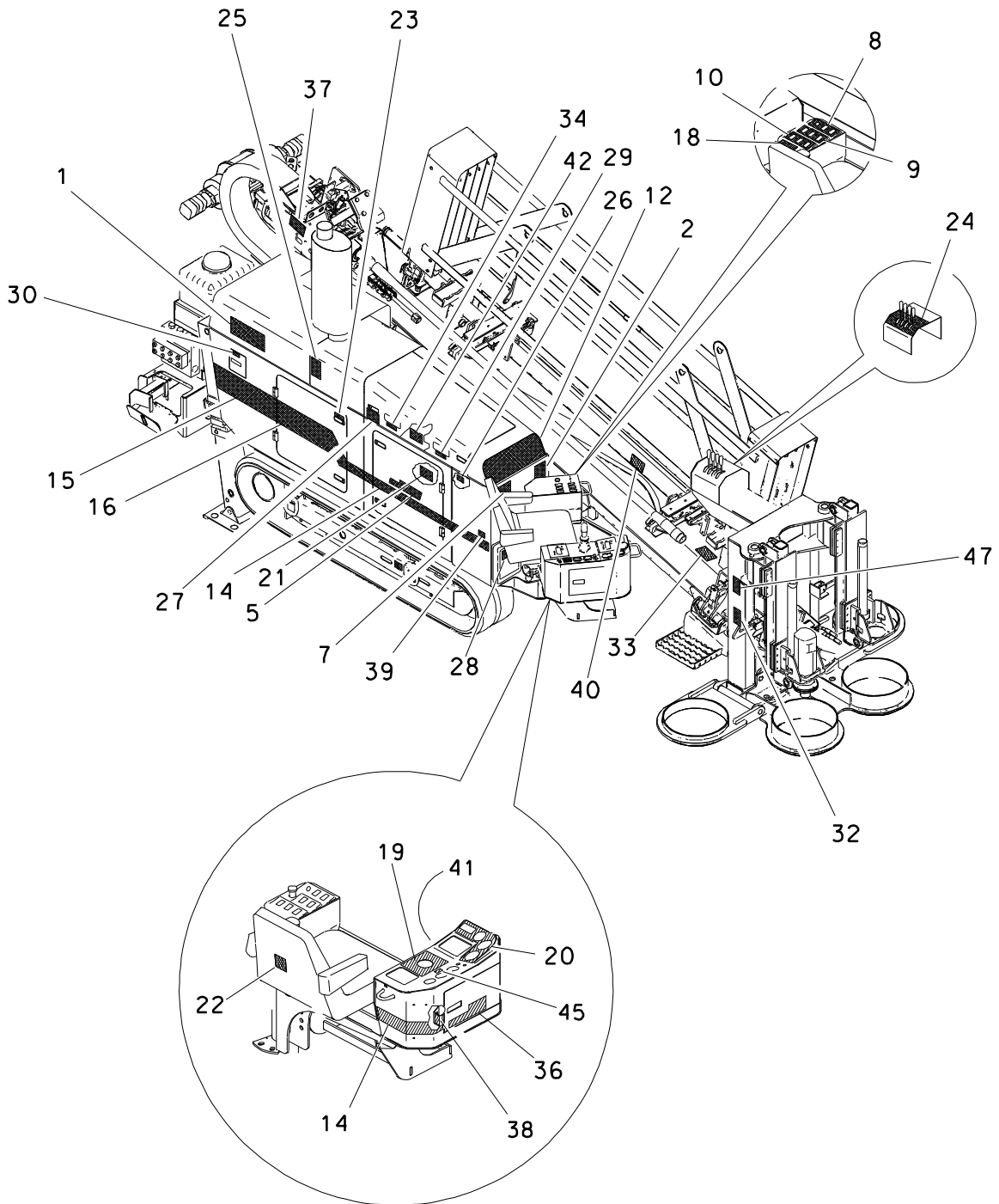

DECAL LOCATION  
 JT2720 MACH 1  
 JT2720 ALL TERRAIN

REF NO.	PART NUMBER	QTY	DESCRIPTION	REMARKS
	275-783		DECAL KIT	JT2720 ALL TERRAIN
	275-869		DECAL KIT	JT2720 MACH 1
1.	274-049	7	DANGER, ELECTROCUTION	4 PER TRAFFIC CONES
2.	274-050	1	DANGER, UNDERGROUND	
3.	274-318	4	TIE-DOWN LOCATION	
4.	274-442	8	LIFT LOCATION	
5.	273-187	1	JT2720 ALL-TERRAIN IDENTIFIER	SEE FOOTNOTE 2
	274-679	1	DECAL - MODEL ID {JT2720}	SEE FOOTNOTE 3
6.	274-724	1	ONE CALL NOTIFICATION	
7.	274-780	1	JET TRAC PATENT(S)	
8.	273-185	1	FRONT-BACK WRENCH	
9.	273-184	1	PIPE-LIFT-SHUTTLE	
10.	273-183	1	FLOW-LUBE-GRIPPER	
11.	274-865	1	SET UP CONTROL PANEL	
12.	273-124	1	ALL TERRAIN INSTRUMENTS	SEE FOOTNOTE 2
	700-051	1	JET TRAC INSTRUMENTS	SEE FOOTNOTE 3
	273-188	1	ALL-TERRAIN INSTRUMENTS	SEE FOOTNOTE 5
13.	273-012	1	AT/JT-IGNITION-COLD START	
14.	274-877	AR	GRAPHIC STRIPE	USE 65"
15.	274-883	1	"DITCH" GRAPHIC STRIPE	
16.	274-884	1	"WITCH" GRAPHIC STRIPE	
17.	273-138	1	NOTICE - COOLANT	
18.	273-182	1	BORE-PIPE-THROTTLE	
19.	273-190	1	JOYSTICK - INDICATOR LIGHTS	
20.	273-189	1	THRUST-ROTATION-FLUID	
21.	274-198	1	DECAL - NOTICE - OIL LEVEL	
22.	275-449	2	DITCH WITCH LOGO PLACARD	
23.	275-400	1	NOTICE OIL LEVEL DECAL	
24.	273-181	1	ANCHOR ROTATION-THRUST	
25.	275-355	1	CAUTION HOT PARTS DECAL	
26.	275-023	1	OIL LEVEL	
27.	275-033	1	NOTICE, ELECTRICAL SYSTEM	
28.	275-048	1	IMPORTANT, SAFETY RULES	
29.	275-120	1	RESERVOIR (THF)	
	274-672	1	ENVIRO HYDRAULIC RESERVOIR	SEE FOOTNOTE 1
30.	275-148	1	FUEL TANK (DIESEL)	
31.	273-146	1	NOTICE, ADD COOLANT	
32.	275-184	3	WARNING, MOVING PARTS	
33.	275-197	2	DANGER, ROTATING SHAFT	
34.	275-203	1	BATTERY DECAL	
35.	275-230	6	WARNING STRIPE (1.750" X 18")	
36.	273-186	1	MACH 1 IDENTIFIER	
37.	275-341	1	WARNING, SLIDING PARTS	
38.	273-198	1	TRACKER CONTROL	
39.	273-016	1	DECAL-SOUND POWER RATING (111 DBA)	SEE FOOTNOTE 4

FOOTNOTES

1. NOT PART OF KIT. SEE 256-030 ENVIRONMENTAL HYDRAULIC OIL.
2. PART OF KIT NUMBER 275-783
3. PART OF KIT NUMBER 275-869
4. NOT PART OF KIT. FOR EUROPEAN UNITS ONLY
5. NOT PART OF KIT. FOR EARLY STYLE INSTRUMENT PANELS

DECAL LOCATION  
JT2720 MACH 1  
JT2720 ALL TERRAIN

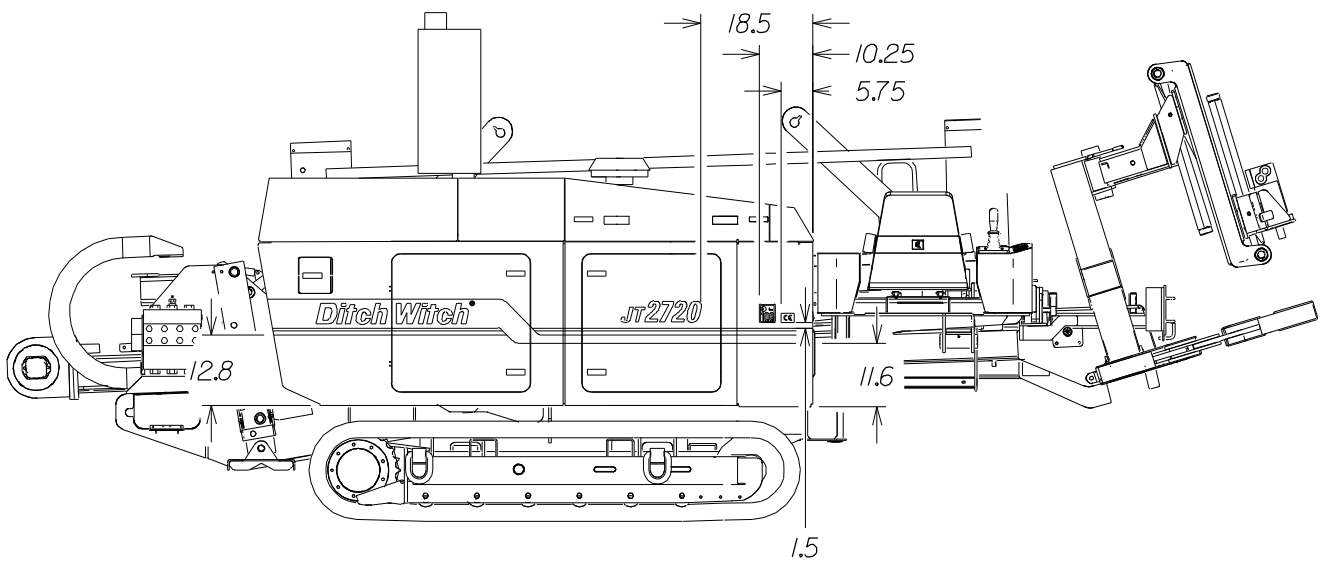

DECAL LOCATION  
JT2720 MACH 1  
JT2720 ALL TERRAIN

REF NO.	PART NUMBER	QTY	DESCRIPTION	REMARKS
40.	273-226	1	SHUTTLE STOP INDICATOR	
41.	273-235	1	CONSOLE ELECTRICAL CENTER	
42.	273-236	1	ENGINE ELECTRICAL CENTER	
43.	273-234	1	PIPELOADER VALVE	
44.	273-233	1	FRONT WRENCH VALVE	
45.	273-230	1	ENGINE - STOP	
46.	273-267	1	BATTERY WARRANTY	SEE FOOTNOTE 6
47.	273-278	1	DANGER WRENCH	

FOOTNOTES

6. LOCATE DECAL ON BATTERY SO THAT DECAL IS VISIBLE WHEN VIEWING BATTERY.







# **ENGINE COMPONENTS**

# ENGINE

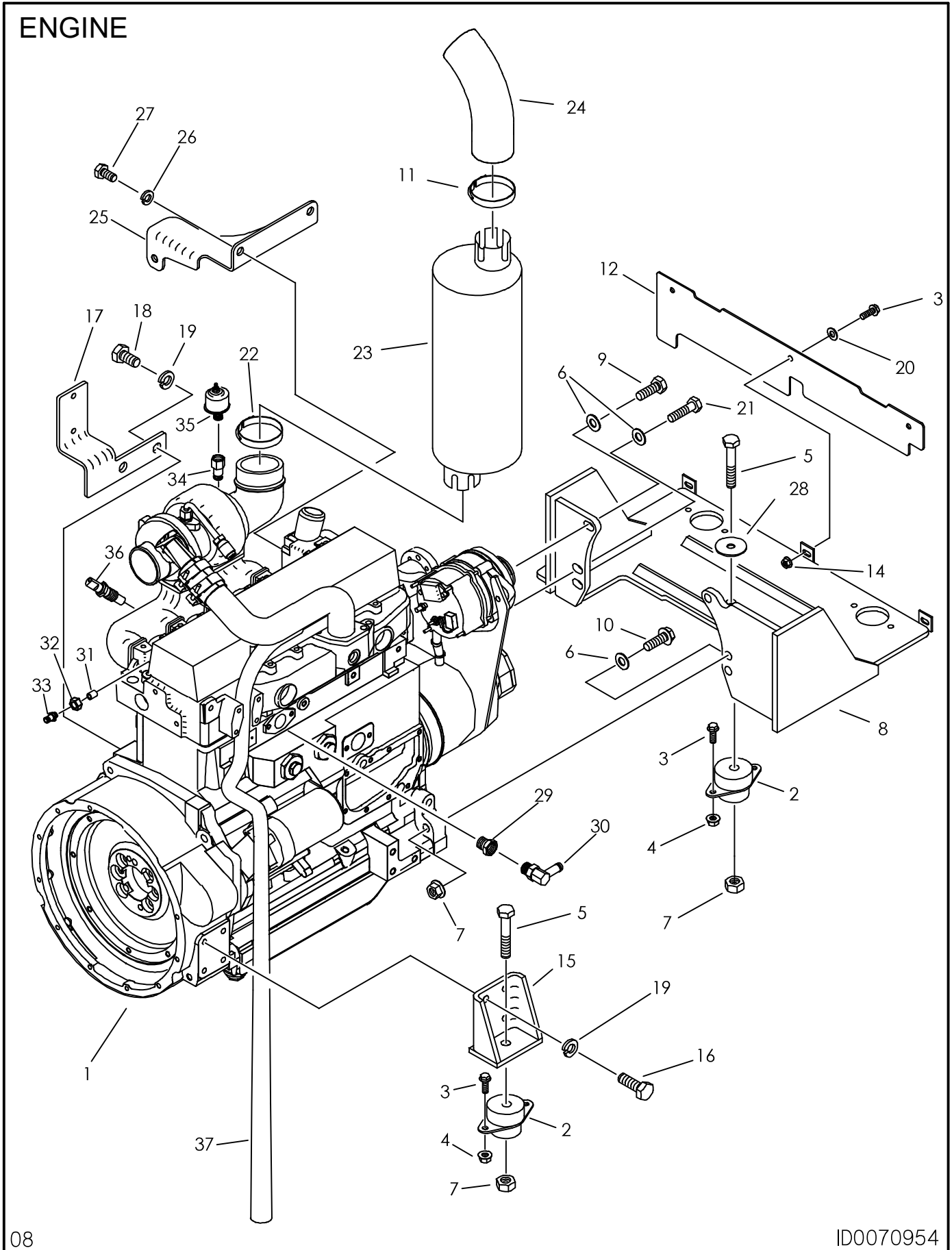

# ENGINE

REF NO.	PART NUMBER	QTY	DESCRIPTION	REMARKS
1.	194-020	1	ENGINE - JOHN DEERE DIESEL	OBSOLETE
	217-450		ALTERNATOR	
	195-897		STARTER	
	194-823		THERMOSTAT	
	165-883		GASKET, THERMOSTAT	
	194-815		OIL FILTER ELEMENT	
	159-231		FUEL FILTER ELEMENT (SPIN-ON)	
	194-493		PRIMARY FILTER SEDIMENT BOWL	BEGINS WITH S/N
	165-755		EXHAUST MUFFLER GASKET	
	165-769		AIR INLET GASKET	
2.	116-488	3	ISOLATION MOUNT	
3.	106-383	6	FLG LK SCREW (M10-1.5 X 30mm)	
4.	106-387	6	FLG LOCKNUT (M10-1.50)	
5.	106-342	3	SCREW (M16-2.00 X 90mm)	
6.	106-398	6	WASHER (M16, HARDENED)	
7.	106-545	5	LOCKNUT (M16-2.0, PRV TRQ, 10.9)	
8.	353-312	1	ENGINE MOUNT	
9.	105-998	4	SCREW (M16-2.00 X 40mm)	
10.	106-341	1	SCREW (M16-2.00 X 70mm)	
11.	194-049	1	MUFFLER CLAMP	
12.	343-416	1	RUBBER GUARD	
13.	106-162	3	FLG SCREW (M8-1.25 X 20mm)	
14.	107-096	3	LOCKNUT (M8-1.25, NLK)	
15.	353-313	2	REAR ENGINE MOUNT	
16.	105-247	8	SCREW (M12-1.75 X 35mm)	
17.	363-677	1	BRACKET	
18.	105-273	2	SCREW (M12-1.75 X 30mm)	
19.	105-070	8	LOCK WASHER (1/2")	
20.	105-117	6	WASHER (5/16")	
21.	106-074	1	SCREW (M16-2.00 X 60mm)	
22.	194-027	1	MUFFLER CLAMP (4.143")	
23.	196-372	1	MUFFLER OUTLINE	
24.	196-373	1	MUFFLER EXTENSION TUBE	
25.	354-661	1	THROTTLE BRACKET	
26.	106-090	2	LOCK WASHER (M10)	
27.	105-245	2	SCREW (M10-1.50 X 25mm)	
28.	106-398	4	WASHER (M16, HARDENED)	
29.	114-033	1	REDUCER (M10-1.00-02NF)	
30.	155-241	1	S/O COUPLER (02N-05H90)	LOCTITE 567
31.	156-277	1	COMPRESSION NUT (05T)	
32.	156-276	1	FERRULE (05T)	
33.	156-275	1	TUBE CONNECTOR (04H-05T)	
34.	156-226	1	REDUCER (02N-02NF)	
35.	215-183	1	SENDER, OIL PRESSURE HD	LOCTITE 567
36.	217-736	1	OIL PRESSURE SWITCH	LOCTITE 567
37.	117-378	AR	BULK HOSE, LOW PRESSURE (-12)	USE 1 @ 93.5"

FOOTNOTES:

# RADIATOR

ENDS WITH S/N 2V2484

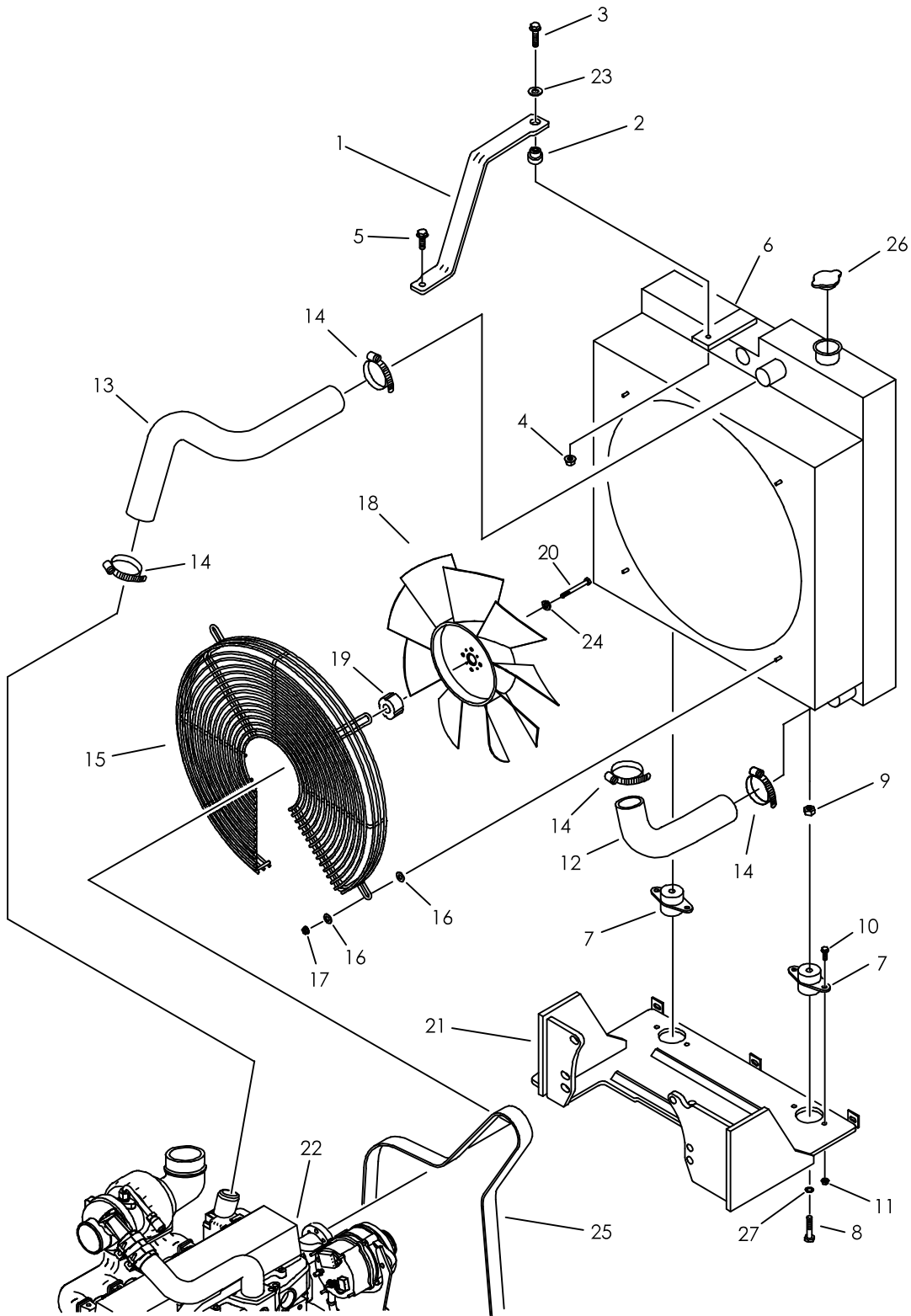

## RADIATOR ENDS WITH S/N 2V2484

REF NO.	PART NUMBER	QTY	DESCRIPTION	REMARKS
1.	343-683	1	TOP RADIATOR BRACKET	
2.	116-727	1	SHOCK MOUNT	
3.	106-628	1	SCREW (M10-1.5 X 60MM)	
4.	105-894	1	LOCKNUT (M10-1.5, PRV TRQ, 10.9)	
5.	107-004	1	FLG LK SCREW (M12-1.75 X 45MM)	
6.	194-245	1	RADIATOR	
7.	116-487	2	ISOLATION MOUNT	
8.	106-700	2	SCREW (M12-1.75 X 80mm)	
9.	106-685	2	LOCKNUT (M12-1.75, PRV TRQ, 10.9)	
10.	106-164	4	FLG LK SCREW (M10-1.50 X 30MM)	
11.	105-894	4	LOCKNUT (M10-1.5,PRV TRQ,10.9)	
12.	116-733	1	LOWER COOLANT HOSE	
13.	116-732	1	UPPER COOLANT HOSE	
14.	110-134	4	WORM CLAMP (2.062" TO 2.750")	
15.	308-867	1	FAN GUARD	
16.	105-117	4	WASHER (5/16")	
17.	107-096	4	LOCKNUT (M8-1.25, NLK)	
18.	194-818	1	FAN (23.0" OD, 2.50" BC)	
19.	184-190	1	COOLING FAN SPACER	
20.	107-078	4	SCREW (M8-1.25 X 90MM)	TORQUE TO 30 FT. LBS.
21.	353-312	-	ENGINE MOUNT	
22.	194-020	-	ENGINE - JOHN DEERE DIESEL	OBSOLETE
23.	106-397	1	WASHER (M12, HARDENED)	
24.	105-091	4	LOCK WASHER (5/16")	
25.	170-354	-	FAN BELT	
26.	111-091	1	CAP	
27.	106-397	1	WASHER (M12, HARDENED)	

NOT SHOWN:

FOOTNOTES:

NOTE:

**RADIATOR**  
BEGINS WITH S/N 2V2657

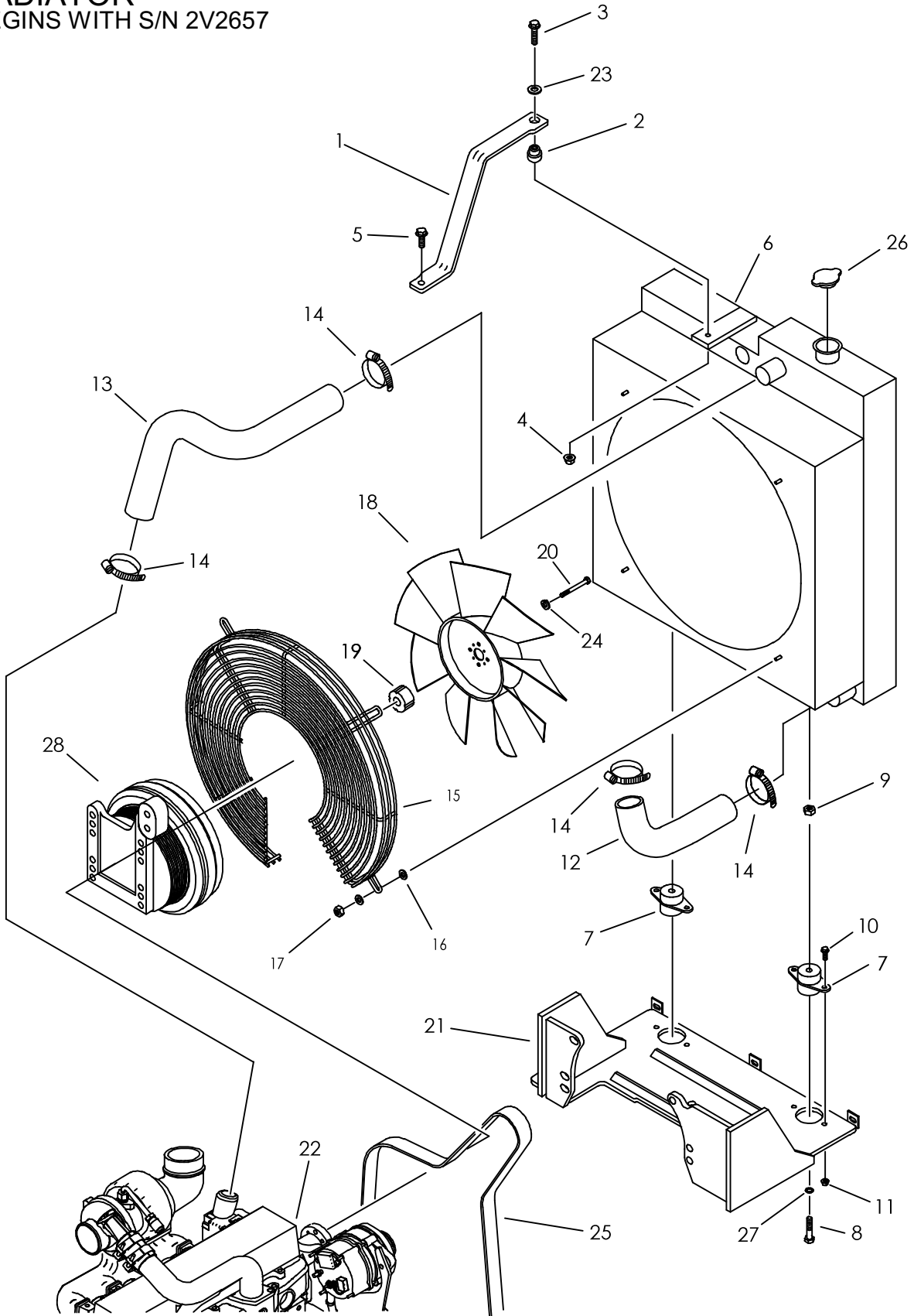



## RADIATOR BEGINS WITH S/N 2V2657

REF NO.	PART NUMBER	QTY	DESCRIPTION	REMARKS
1.	343-683	1	TOP RADIATOR BRACKET	
2.	116-727	1	SHOCK MOUNT	
3.	106-628	1	SCREW (M10-1.5 X 60MM)	
4.	105-894	1	LOCKNUT (M10-1.5, PRV TRQ, 10.9)	
5.	107-004	1	FLG LK SCREW (M12-1.75 X 45MM)	
6.	194-245	1	RADIATOR	
7.	116-487	2	ISOLATION MOUNT	
8.	106-700	2	SCREW (M12-1.75 X 80mm)	
9.	106-685	2	LOCKNUT (M12-1.75, PRV TRQ, 10.9)	
10.	106-164	4	FLG LK SCREW (M10-1.50 X 30MM)	
11.	105-894	4	LOCKNUT (M10-1.5, PRV TRQ, 10.9)	
12.	116-733	1	LOWER COOLANT HOSE	
13.	116-732	1	UPPER COOLANT HOSE	
14.	110-134	4	WORM CLAMP (2.062" TO 2.750")	
15.	318-646	1	FAN GUARD	
16.	105-117	4	WASHER (5/16")	
17.	107-096	4	LOCKNUT (M8-1.25, NLK)	
18.	194-818	1	FAN (23.0" OD, 2.50" BC)	
19.	178-991	1	COOLING FAN SPACER	
20.	106-063	4	SCREW (M8-1.25 X 40MM, 10.9)	TORQUE TO 30 FT. LBS.
21.	353-312	-	ENGINE MOUNT	
22.	194-020	-	ENGINE - JOHN DEERE DIESEL	OBSOLETE
23.	106-397	1	WASHER (M12, HARDENED)	
24.	105-091	4	LOCK WASHER (5/16")	
25.	170-378	1	FAN BELT	
26.	111-091	1	CAP	
27.	106-397	1	WASHER (M12, HARDENED)	
28.	194-251	-	FAN CLUTCH (154 MM PULLY)	

NOT SHOWN:

FOOTNOTES:

NOTE:

# FAN CLUTCH

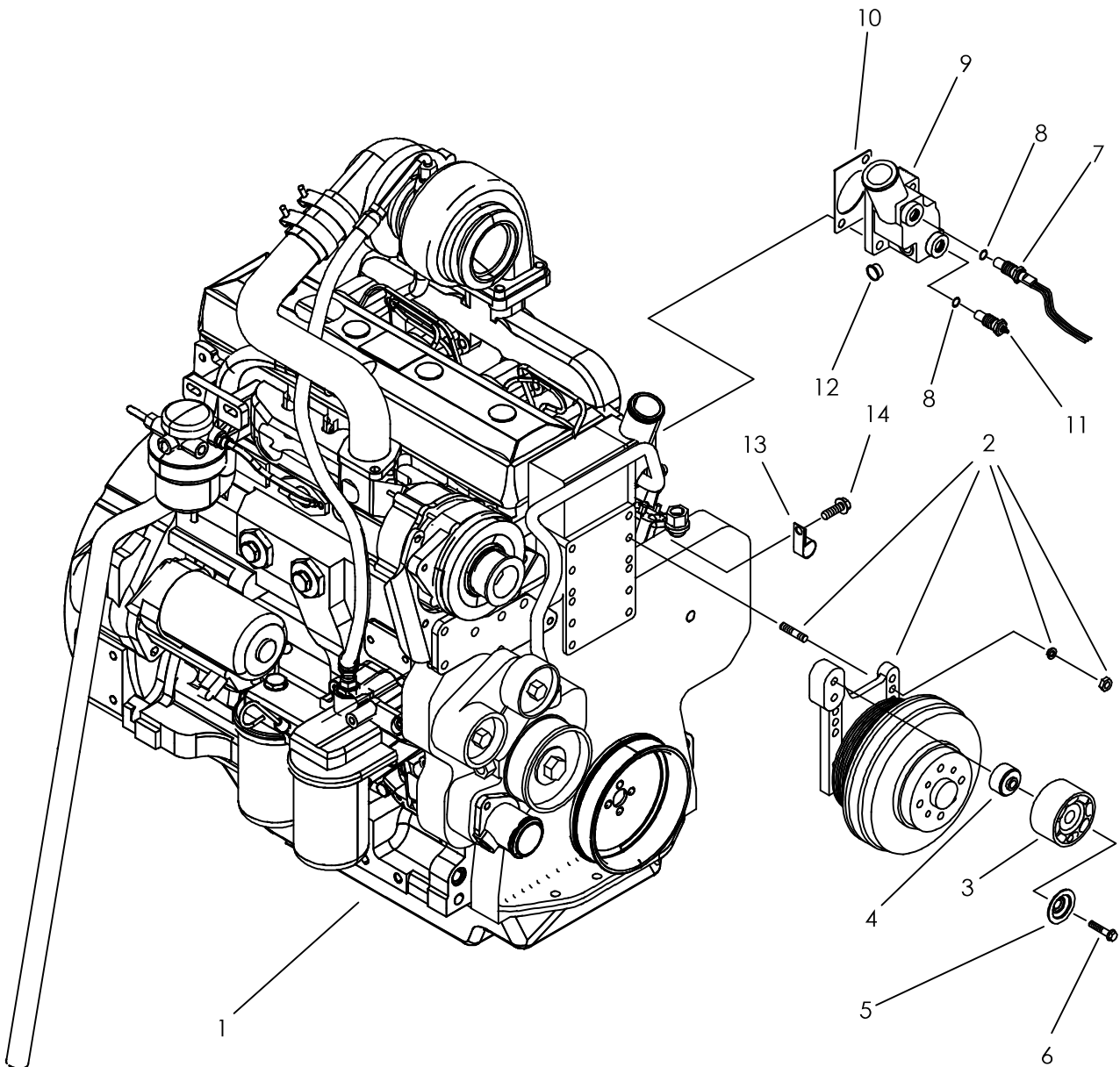

## FAN CLUTCH

REF NO.	PART NUMBER	QTY	DESCRIPTION	REMARKS
1.	194-020	-	ENGINE - JOHN DEERE DIESEL	OBSOLETE
2.	194-251	1	FAN DRIVE (JT/AT 2720)	
3.	170-372	1	IDLER PULLY	
4.	179-462	1	SPACER	
5.	179-461	1	SLEEVE	
6.	106-998	1	FLG HEX SCREW (M10-1.50 X 70MM)	
7.	214-895	1	TEMPERATURE SWITCH	
8.	155-705	2	O-RING (906 D90)	
9.	164-027	1	THERMOSTAT HOUSING	
10.	165-883	1	GASKET, THERMOSTAT	
11.	217-550	1	WATER TEMPERATURE SENDER	
12.	153-993	1	GASKET, THERMOSTAT TUBE	
13.	110-126	1	BOLT ON CLAMP (1/2")	
14.	106-382	1	FLG LK SCREW (M10-1.50 X 20MM)	

NOT SHOWN:

FOOTNOTES:

NOTE:

## COOLANT SYSTEM

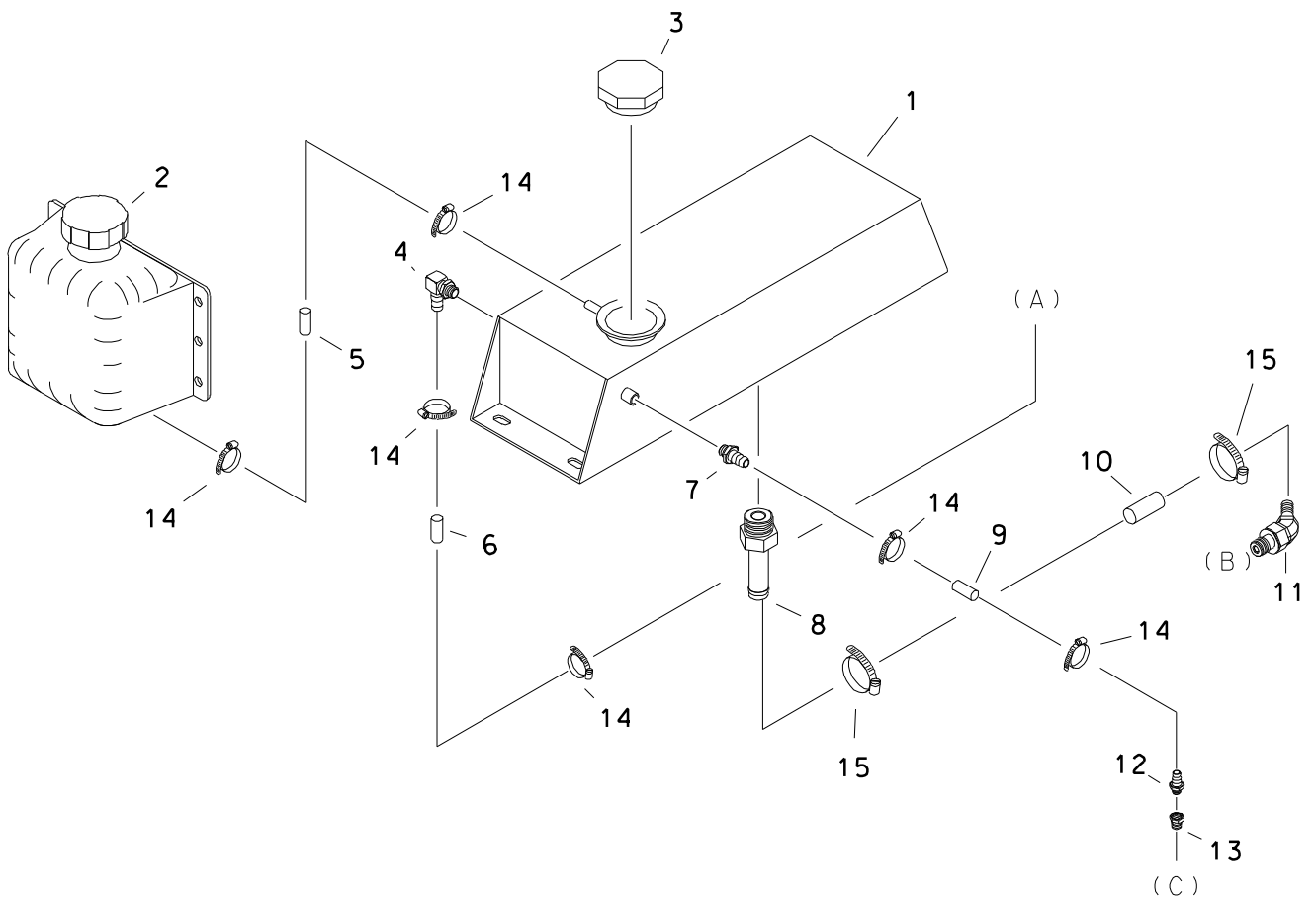

# COOLANT SYSTEM

REF NO.	PART NUMBER	QTY	DESCRIPTION	REMARKS
1.	364-543	-	EXPANSION TANK	
2.	364-229	-	OVERFLOW TANK (3 QT)	
	110-765	1	CAP (2-1/4")	
3.	111-084	1	RADIATOR CAP (16PSI)	
4.	155-164	1	S/O COUPLER (04N-05H90)	
5.	116-108	AR	BULK HOSE (5/16", SOLD PER 1")	USE 1 @ 24"
6.	116-108	AR	BULK HOSE (5/16", SOLD PER 1")	USE 1 @ 27"
7.	155-162	1	COUPLER (04N-5/16OD,STR)	
8.	514-140	1	S/O COUPLER (08N-10H)	
9.	116-108	AR	BULK HOSE (5/16", SOLD PER 1")	USE 1 @ 52"
10.	116-750	AR	BULK HOSE (5/8", SOLD PER 1")	USE 1 @ 68"
11.	153-160	1	ELBOW (45 DEG SPECIAL)	
12.	155-162	1	COUPLER (04N-5/16OD,STR)	
13.	115-286	1	PIPE BUSHING (1/2NMX1/4NF)	
14.	110-249	6	WORM CLAMP (1/4" TO 5/8")	
15.	110-217	2	WORM CLAMP (7/16" TO 1")	

FOOTNOTES

- (A) CONNECTS INTO RADIATOR OVERFLOW
- (B) CONNECTS INTO ENGINE WATER PUMP
- (C) CONNECTS INTO ENGINE CYLINDER HEAD

## AIR FILTER SYSTEM

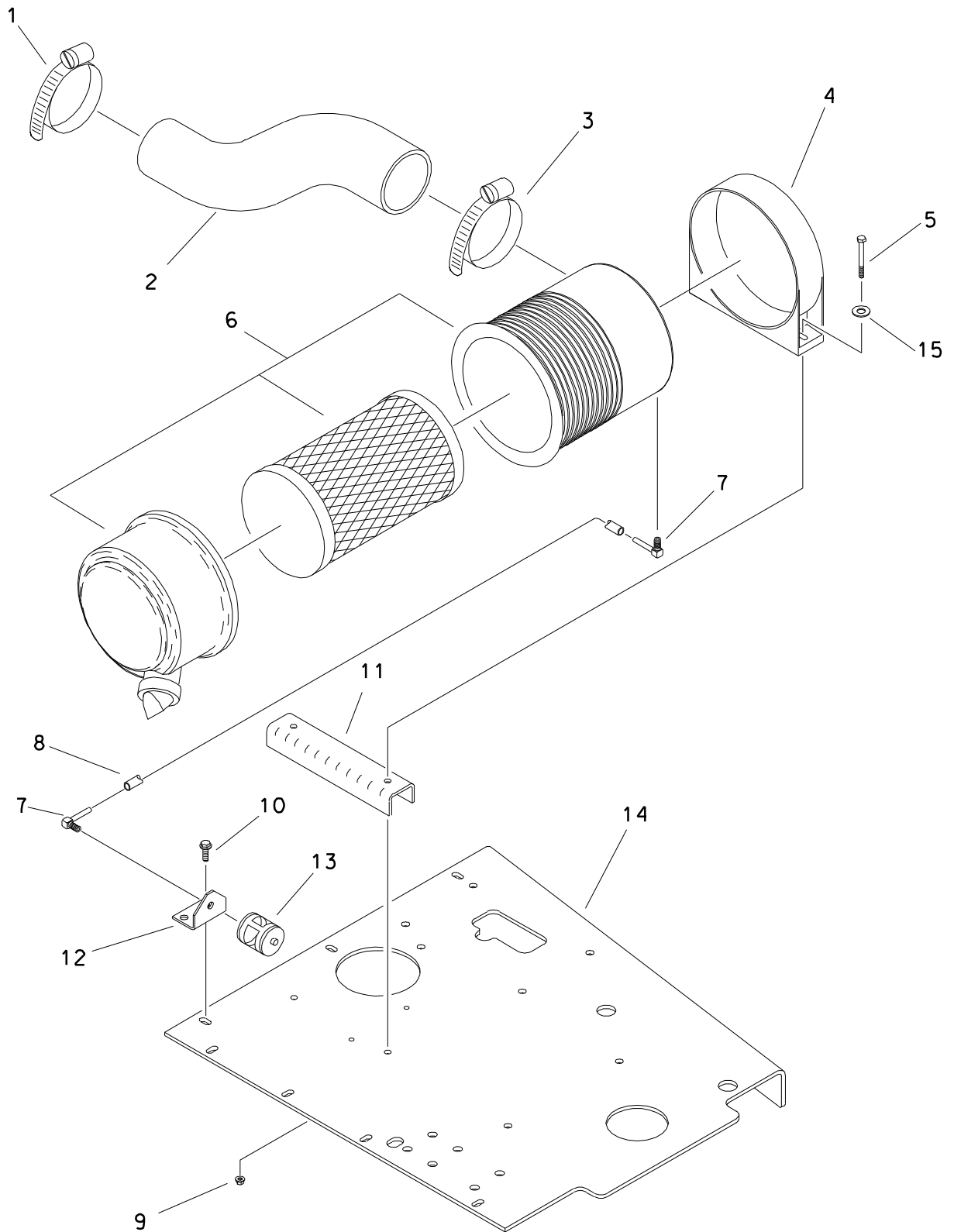

# AIR FILTER SYSTEM

REF NO.	PART NUMBER	QTY	DESCRIPTION	REMARKS
1.	110-169	1	WORM CLAMP (2.812" TO 3.750")	
2.	120-555	1	FILTER HOSE	
3.	110-367	1	WORM CLAMP (3.250" TO 4.125")	
4.	120-080	1	MOUNTING CLAMP (8.350")	
5.	106-330	2	SCREW (M8-1.25 X 70MM)	
6.	120-081	1	AIR FILTER	
	194-830		FILTER ELEMENT	
7.	155-241	2	SLIP-ON COUPLER (02N-05H90)	LOCTITE 567
8.	116-108	AR	BULK HOSE (5/16", SOLD PER 1')	USE 1 @ 20'
9.	106-561	2	LOCKNUT (M8-1.25, PRV TRQ, 10.9)	
10.	106-992	2	FLG LK SCREW (M8-1.25 X 25MM)	
11.	343-970	1	SPACER	
12.	348-846	1	RESTRICTION INDICATOR SUPPORT	
13.	194-788	1	RESTRICTION INDICATOR (25"H2O)	
14.	305-677	-	PLATE, BATTERY SUPPORT	
15.	105-117	2	WASHER (5/16")	

FOOTNOTES

# REMOTE ENGINE OIL DRAIN

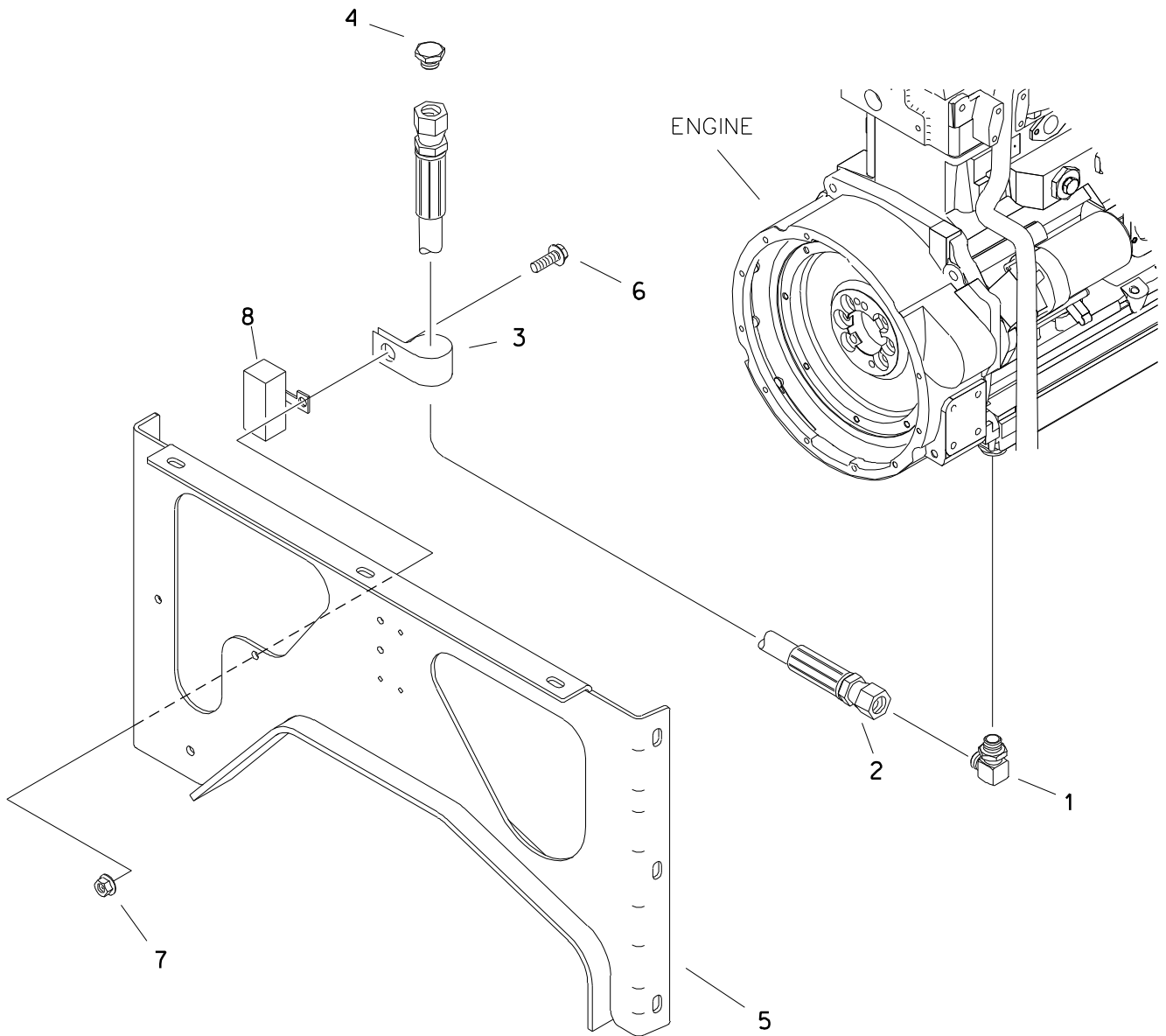



# REMOTE ENGINE OIL DRAIN

REF NO.	PART NUMBER	QTY	DESCRIPTION	REMARKS
1.	154-467	1	CONNECTOR (M18-1.50-08J90)	
2.	154-894	1	HOSE (08JFX-30"-3000)	
3.	110-332	1	BOLT-ON CLAMP (1-5/8")	
4.	154-093	1	PLUG (08J)	
5.	343-775	-	SHEET METAL SUPPORT	
6.	106-724	1	FLG SCREW (M10-1.50 X 25mm)	
7.	106-387	1	FLG LOCKNUT (M10-1.50)	
8.	214-449	1	DIODE CONNECTOR	

FOOTNOTES

# COLD START KIT

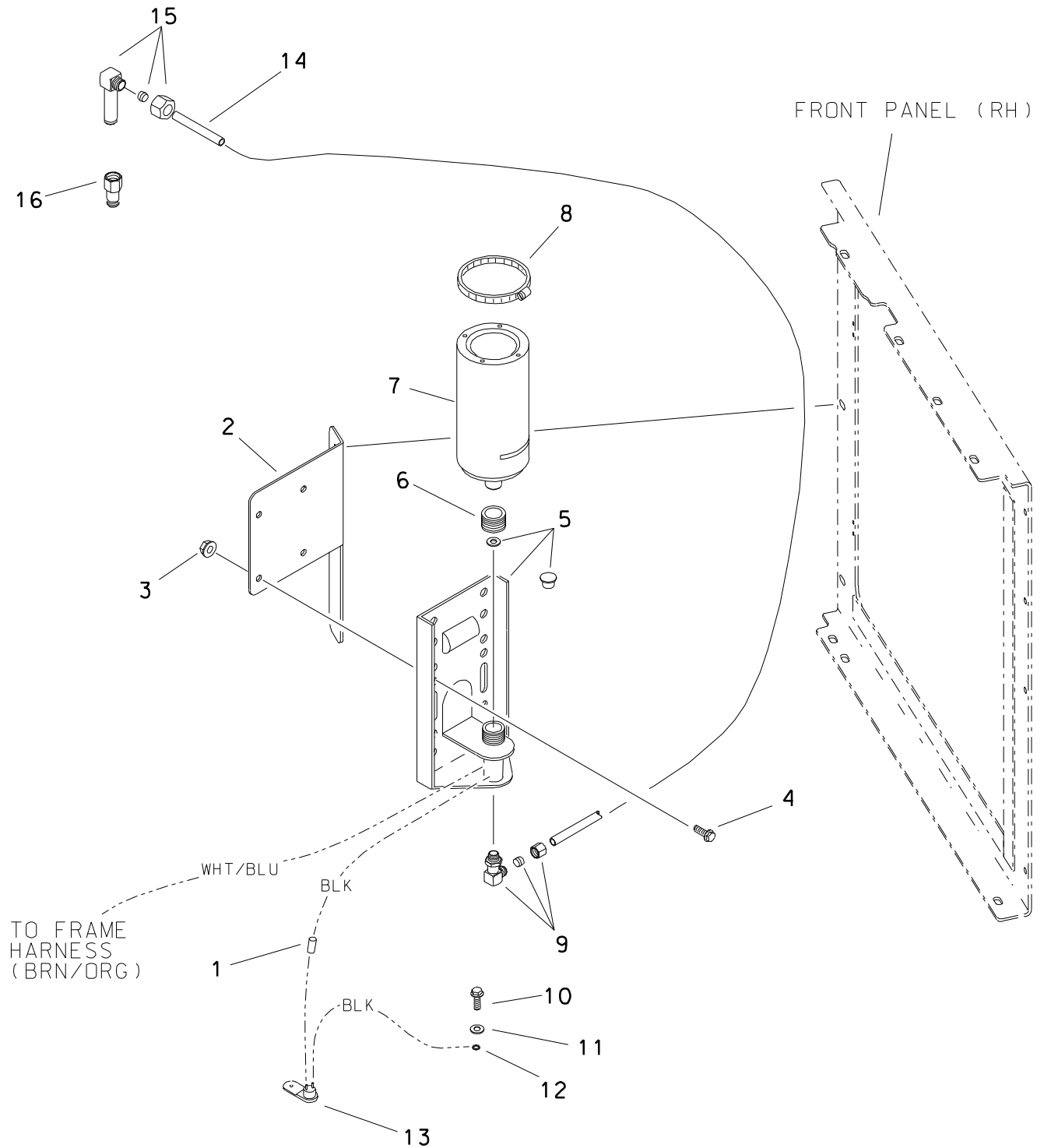

## COLD START KIT

REF NO.	PART NUMBER	QTY	DESCRIPTION	REMARKS
	190-881		COLD START CONVERSION KIT	INCL REF NO'S 2-6 & 8-17; SEE FOOTNOTE 1
1.	215-478		BUTT CONNECTOR (14-16 GA)	
2.	343-318	1	COLD START BRACKET	
3.	106-386	2	FLG LOCKNUT (M8-1.25)	
4.	106-162	4	FLG SCREW (M8-1.25 X 20MM)	
5.	195-841	1	VALVE/CANISTER BRACKET	
	110-252		CAPLUG (3/4")	
	195-844		GASKET	
6.	115-365	1	GROMMET (2-1/8", SOLD PER 1")	
7.	195-842	1	ETHER CANISTER	SEE FOOTNOTE 2
8.	110-367	1	WORM CLAMP (3.250" TO 4.125")	
9.	156-272	1	TUBE CONNECTOR (O2N-O2T90,ORF)	INCL FERRULE & NUT, SEE FOOTNOTE 3
	156-204		FERRULE (O2T)	
	156-205		COMPRESSION NUT (O2T)	
10.	106-382	1	FLG LK SCREW (M10-1.5 X 20MM)	
11.	105-072	1	LOCK WASHER (3/8")	
12.	215-590	1	RING TERMINAL (3/8")	
13.	215-073	1	SENSOR SWITCH	
14.	156-018	AR	BULK TUBING (1/8", SOLD PER 1")	USE 1 @ 63"
15.	195-843	1	INJECTOR NOZZLE	INCL FERRULE & NUT, SEE FOOTNOTE 3
	156-204		FERRULE (O2T)	
	156-205		COMPRESSION NUT (O2T)	
16.	514-402		CONNECTOR (10S - O2NF)	

## NOT SHOWN

110-248 CABLE TIE (1/16" - 1/4")

## FOOTNOTES

1. REFER TO INSTALLATION INSTRUCTIONS 051-198
2. NOT PART OF KIT; NEED TO ORDER SEPARATELY.
3. DO NOT INSTALL WITH LOCTITE 567



# **FRAME COMPONENTS**

## PIVOT

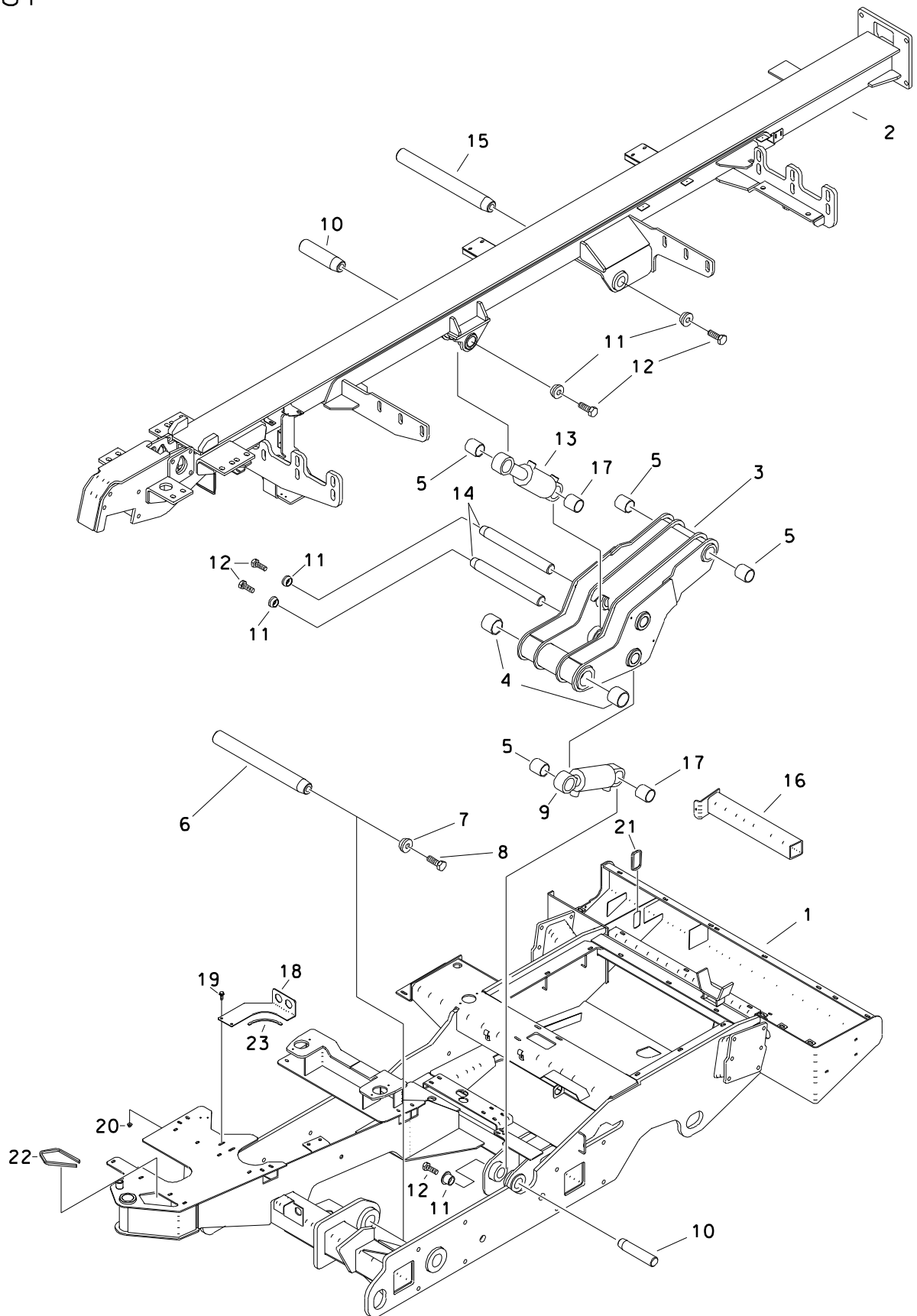

# PIVOT

REF NO.	PART NUMBER	QTY	DESCRIPTION	REMARKS
1.	305-710	-	MAIN FRAME	
2.	303-648	1	DRILL FRAME WLDMN'T	
3.	305-874	1	LINK WELDMENT	
4.	125-762	2	SPRING BUSHING (2.500")	
5.	125-754	4	COMPOSITION BUSHING (2.000")	
6.	179-186	1	TAPERED PIN (63.5mm X 480mm)	
7.	184-575	1	TAPERED INSERT (2.500")	
8.	106-667	1	SCREW (M24-3.0 X 65mm, 10.9)	LOCTITE 277
9.	149-698	1	CYLINDER ASSEMBLY	
10.	179-188	2	TAPERED PIN (50.8mm X 158mm)	
11.	184-064	5	TAPERED INSERT (2.000")	
12.	106-607	5	SCREW (M20-2.50 X 50MM, 10.9)	LOCTITE 277
13.	151-066	1	CYL (4.0" X 2.0" X 5.0")	
14.	179-189	2	TAPERED PIN (50.8MM X 300MM)	
15.	179-187	1	TAPERED PIN (50.8mm X 390mm)	
16.	343-242	1	SUPPORT	SERVICE PROP ROD
17.	125-844	2	COMPOSITION BUSHING (2")	
18.	306-501	1	ELECTRIC BULKHEAD	
19.	106-724	2	FLG SCREW (M10-1.50 X 25MM)	
20.	106-387	2	FLG LOCKNUT (M10-1.50)	
21.	115-686	AR	BULK EDGE (5/32", SOLD PER 1")	USE 1 @ 9"
22.	115-704	AR	BULK EDGE (1/4", SOLD PER 1")	USE 1 @ 17"
23.	115-686	AR	BULK EDGE (5/32", SOLD PER 1")	USE 1 @ 7"

FOOTNOTES

# HOSE TRACK JT2720 MACH 1 ONLY

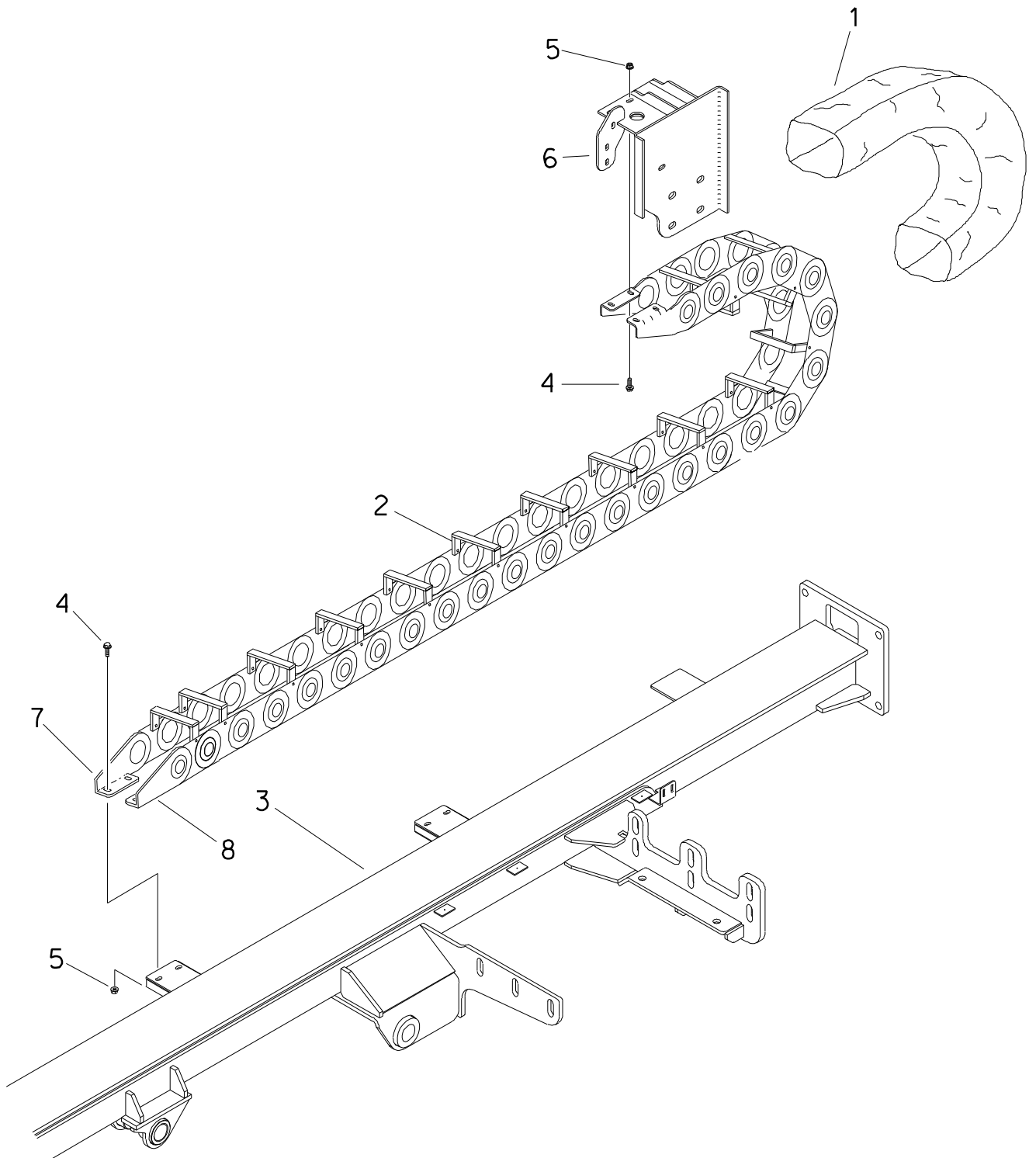



# HOSE TRACK JT2720 MACH1 ONLY

REF NO.	PART NUMBER	QTY	DESCRIPTION	REMARKS
1.	117-361	1	CABLE BAG	
2.	343-231	1	HOSE TRAC	
-	117-626	-	4 LINK REPAIR SECTION	- - - - -
-	191-190	-	HARDWARE KIT	- - - - -
-	359-941	12	EASY-OUT BAR (1/2" X 5-3/4")	- - - - -
-	359-942	12	ALUMINUM BAR (1/2" X 5-3/4")	- - - - -
-	307-339	12	6" ALUMINUM FLAT BAR	- - - - -
-	308-834	24	WINDOW EXTENDER	- - - - -
3.	303-648	-	DRILL FRAME	- - - - -
4.	105-600	8	CARRIAGE BOLT (3/8-NC X 1")	- - - - -
5.	105-834	8	FLG LOCKNUT (3/8-NC)	- - - - -
6.	309-775	-	HOSE TRACK MOUNT	- - - - -
7.	307-338	2	BRACKET (RIGHT)	- - - - -
8.	307-337	2	BRACKET (LEFT)	- - - - -

FOOTNOTES

# HOSE TRACK

JT2720 MACH 1 ALL TERRAIN ONLY

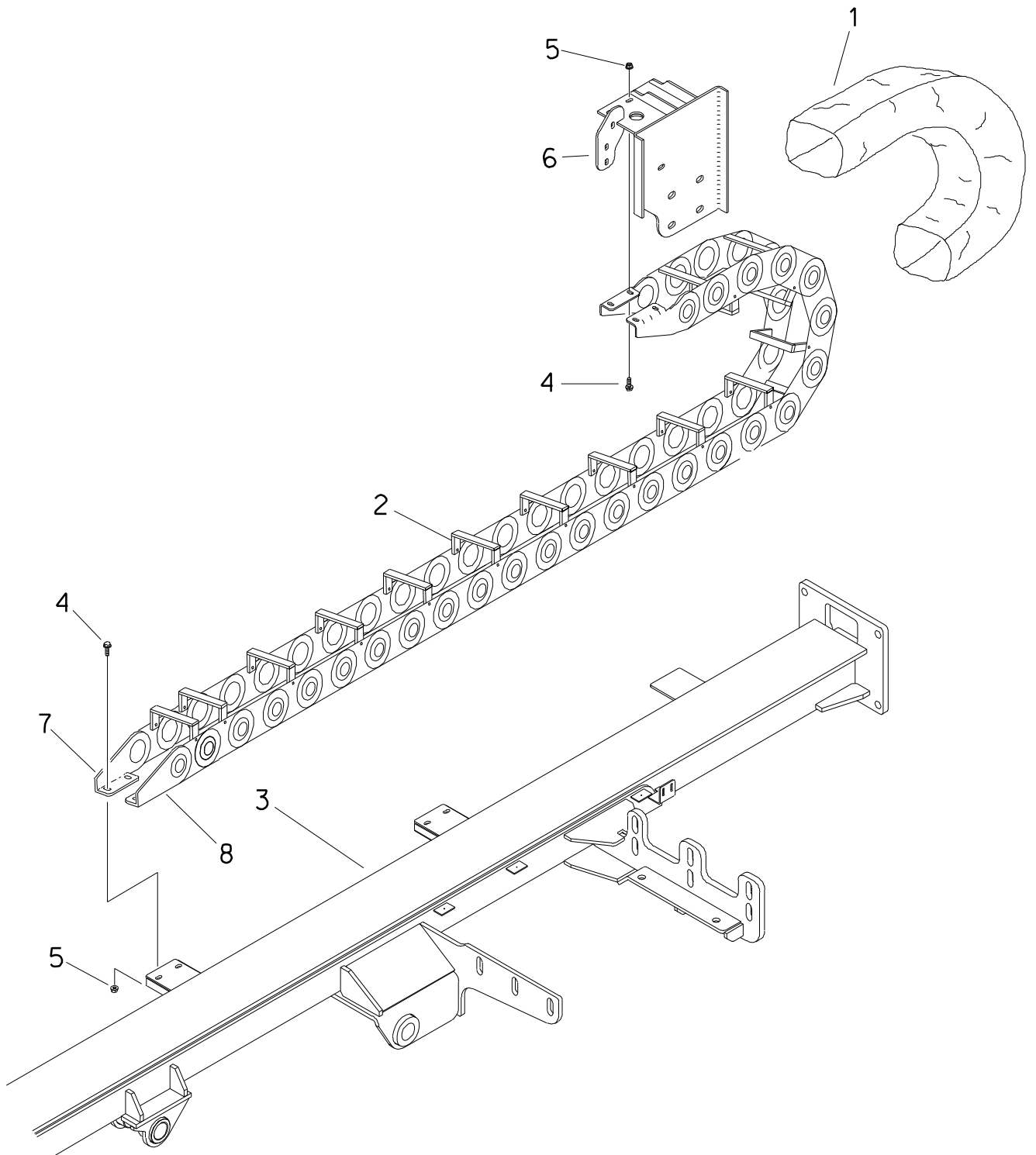

# HOSE TRACK JT2720 MACH 1 ALL TERRAIN ONLY

REF NO.	PART NUMBER	QTY	DESCRIPTION	REMARKS
1.	117-282	1	CABLE BAG	
2.	343-231	1	HOSE TRAC	
-	117-626	-	4 LINK REPAIR SECTION	- - - - -
-	191-190	-	HARDWARE KIT	- - - - -
-	359-941	12	EASY-OUT BAR (1/2" X 5-3/4")	- - - - -
-	359-942	12	ALUMINUM BAR (1/2" X 5-3/4")	- - - - -
-	307-339	12	6" ALUMINUM FLAT BAR	- - - - -
-	308-834	24	WINDOW EXTENDER	- - - - -
3.	303-648	-	DRILL FRAME	- - - - -
4.	105-600	8	CARRIAGE BOLT (3/8-NC X 1")	- - - - -
5.	105-834	8	FLG LOCKNUT (3/8-NC)	- - - - -
6.	309-775	-	HOSE TRACK MOUNT	- - - - -
7.	307-338	2	BRACKET (RIGHT)	- - - - -
8.	307-337	2	BRACKET (LEFT)	- - - - -

FOOTNOTES

## CARRIAGE CHAIN

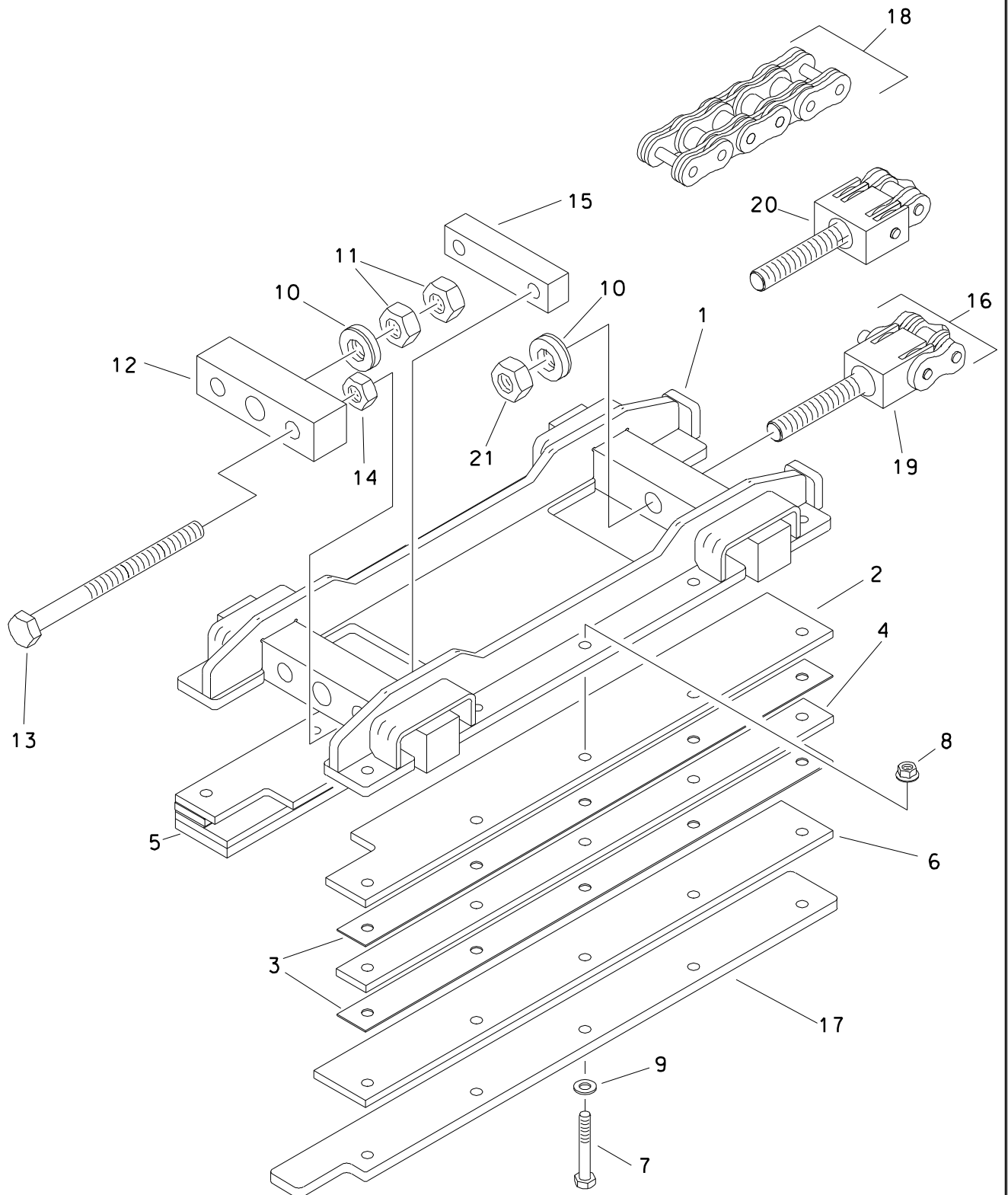

# CARRIAGE CHAIN

REF NO.	PART NUMBER	QTY	DESCRIPTION	REMARKS
1.	303-304	-	CARRIAGE	
2.	309-568	2	SLIDE BAR, TOP	
3.	309-622	4	SHIM PLATE	
4.	309-621	2	SLIDE BAR	
5.	309-623	1	BACKUP PLATE	
6.	309-570	2	SLIDE BAR, BOTTOM	
7.	106-578	10	SCREW (M12-1.75 X 80mm)	
8.	106-685	10	LOCKNUT (M12-1.75,PRV TRQ,10.9)	
9.	106-397	10	WASHER (M12, HARDENED)	
10.	107-273	2	WASHER (1/2")	
11.	106-352	2	HEX NUT (M24-3.00) ZP	
12.	343-758	1	BAR, CHAIN TENSIONER	
13.	105-594	2	SCREW (M20-2.50 X 240MM)	
14.	106-374	4	HEX NUT (M20-2.50, 10.9) ZP	
15.	343-759	1	THREADED BAR	
16.	129-009	1	ROLLER CHAIN (#140-ECH, 205P)	
17.	306-581	1	BAR, BACKUP	
18.	191-044	-	CHAIN REPAIR KIT (#140 ECH,5P)	
19.	130-612	-	CLEVIS (#140-2)	USED WITH FULL LENGTH CHAIN
20.	107-448	-	140-EC CLEVIS	USED WITH CHAIN SHORTENED 1 PITCH.
21.	106-587	1	LOCKNUT (M24-3.0,PRV TRQ,10.9)	

FOOTNOTES

# THRUST DRIVE

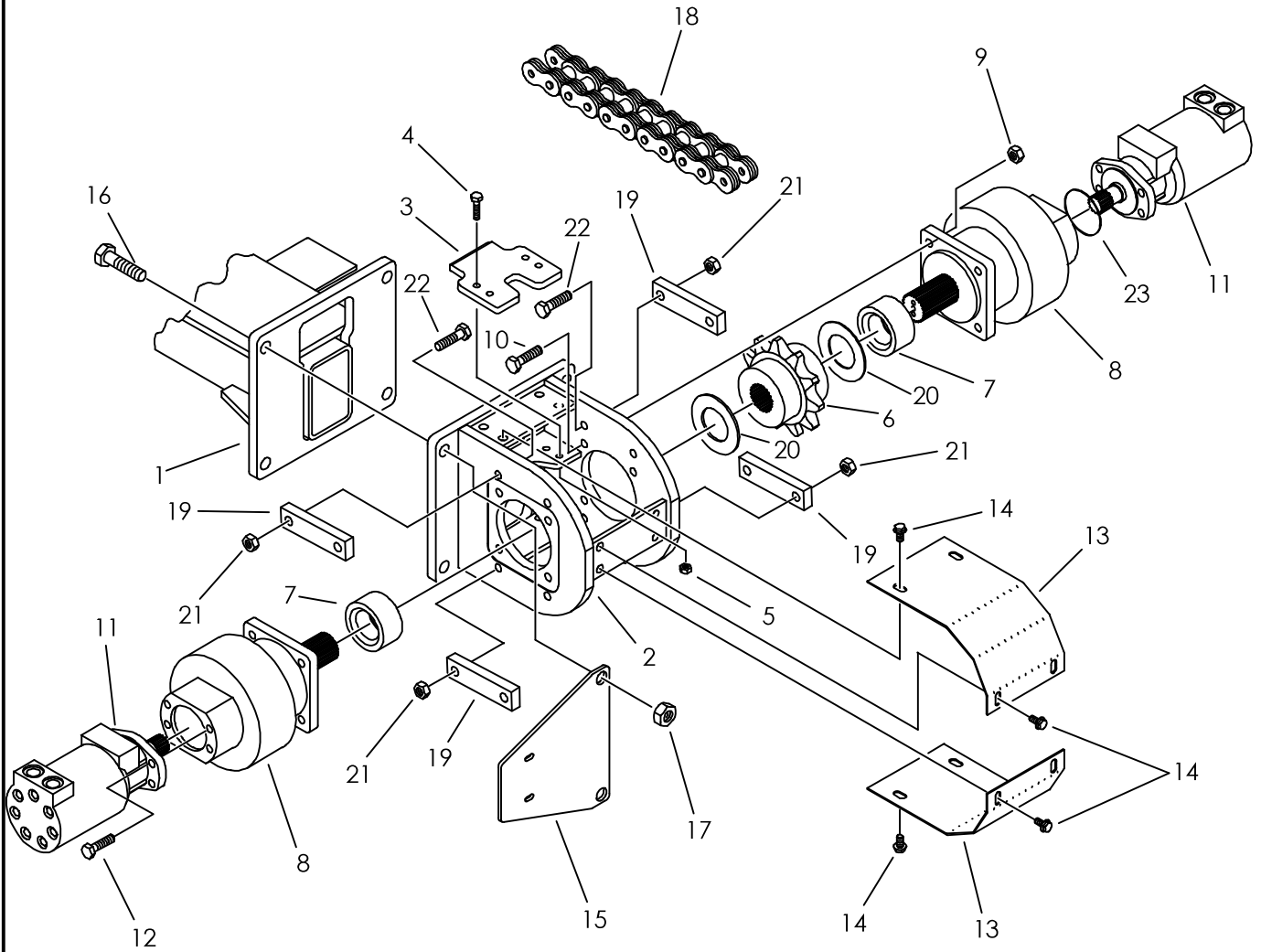

# THRUST DRIVE

REF NO.	PART NUMBER	QTY	DESCRIPTION	REMARKS
1.	303-648	-	DRILL FRAME	
2.	353-417	1	MOUNT, THRUST DRIVE	
3.	305-616	1	WEAR PLATE	
4.	105-271	4	SCREW (M10-1.5 X 40MM)	
5.	105-894	4	LOCKNUT(M10-1.50,PRV TRQ,10.9)	
6.	1 5-738	1	SPROCKET (140B11)	
7.	353-383	2	SPACER	
8.	<del>166-292</del>	2	THRUST DRIVE GEARBOX	
	166-333	2	GEARBOX, PLANETARY, AXIAL	THRUST DRIVE
	190-061	AR	SEAL REPAIR KIT	
	190-799	AR	BEARING & SEAL REPAIR KIT	
	125-368	2	TAPERED RACE (4.330")	
	125-387	1	TAPERED BEARING (2.625")	
	125-388	1	TAPERED BEARING (2.687")	
	157-521	1	EXTERNAL SEAL (3.375")	
	501-629	AR	EXTERNAL SNAP RING SET (2.63")	
	<del>501-725</del>	1	THRUST WASHER (.____")	
	499-893	1	THRUST WASHER (1.031")	
9.	107-319	8	LOCKNUT (M14-2.0, PRV TRQ,10.9)	
10.	107-318	8	SCREW (M14-2.0 X 60mm, 10.9)	
11.	153-141	-	HYDRAULIC MOTOR	THRUST
	500-510	-	SEAL REPAIR KIT	
12.	106-204	8	BOLT (1/2-NC X 1-1/2", SOC)	TORQUE TO 130 FT LBS- 242 LOCTITE
13.	353-380	2	COVER	
14.	106-382	8	FLG LK SCREW (M10-1.5 X 20mm)	
15.	343-453	1	MOUNT PLATE	
16.	106-346	4	SCREW (M20-2.5 X 70mm)	
17.	106-665	4	LOCKNUT (M20-2.50, 10.9)	
18.	129-009	-	ROLLER CHAIN (#140-ECH, 205P)	
19.	343-322	4	PLANETARY SUPPORT BAR	
20.	181-504	2	BUSHING	
21.	105-065	8	LOCKNUT (1/2-NC)	
22.	106-575	8	BOLT (1/2-NC X 2-1/4", GD8)	
23.	157-099	1	O-RING (O42 D70)	

NOT SHOWN:

FOOTNOTES:

NOTE:

# FRONT SPROCKET

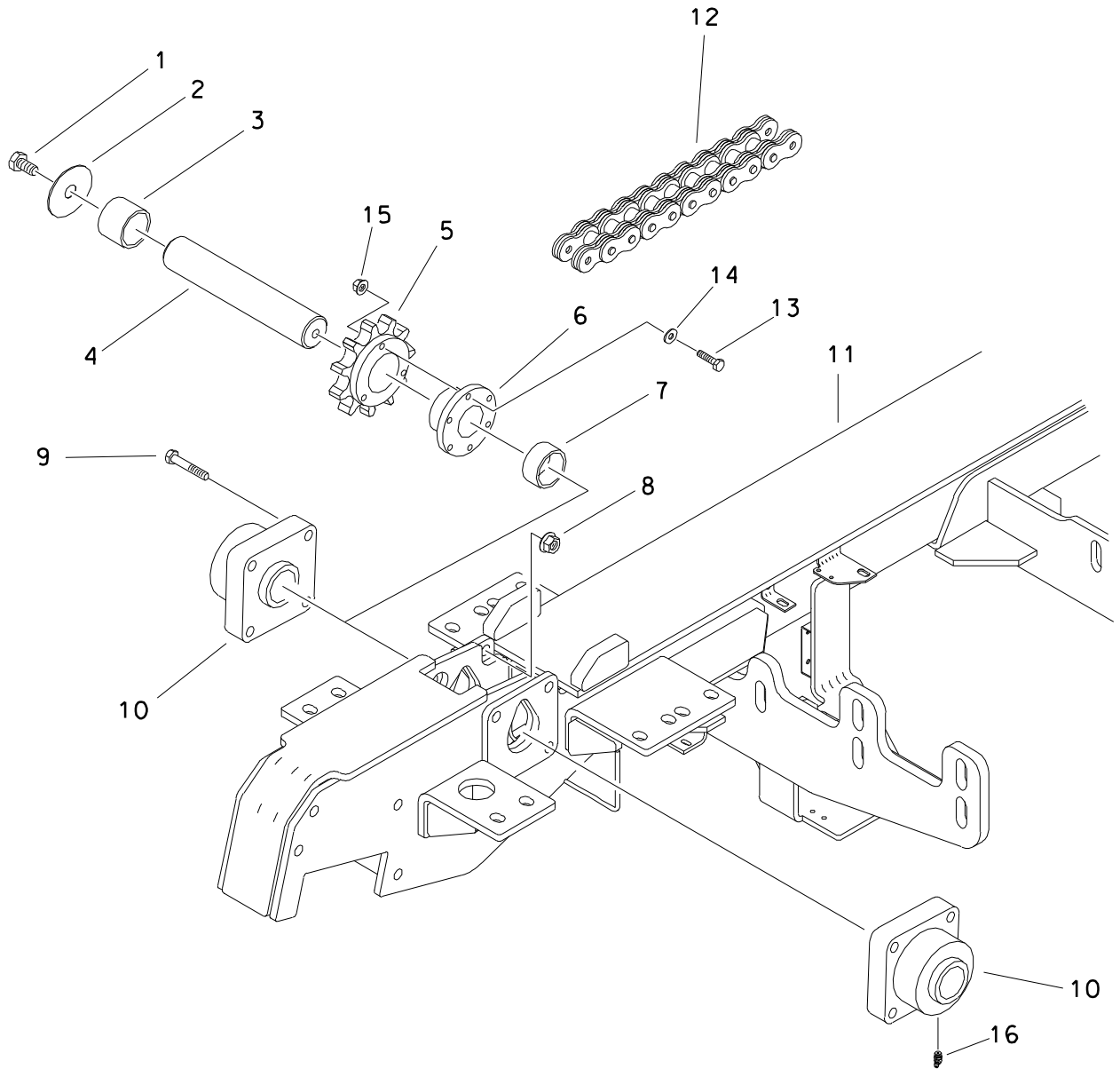



# FRONT SPROCKET

REF NO.	PART NUMBER	QTY	DESCRIPTION	REMARKS
1.	106-470	2	FLG SCREW (M16-2.00 X 40MM)	
2.	107-660	2	WASHER	
3.	343-621	1	RIGHT SPACER	
4.	343-792	1	IDLER SHAFT	
5.	175-700	1	SPROCKET (140A11)	
6.	178-082	1	BUSHING (2.187", QT)	
7.	343-622	1	LEFT SPACER	
8.	106-545	8	LOCKNUT (M16-2.00, PRV TRQ, 10.9)	
9.	106-340	8	SCREW (M16-2.00 X 50mm)	
10.	125-154	2	FLANGE BEARING (2.187")	SEE FOOTNOTE 1
11.	303-648	-	DRILL FRAME	
12.	129-009	-	ROLLER CHAIN (#140-ECH, 205P)	
13.	105-667	3	SCREW (3/8-NC X 2.50", GD8)	TORQUE TO 52 FT LBS LOCTITE 242
14.	107-594	3	WASHER (.406", HARDENED)	
15.	105-047	3	LOCKNUT (3/8-NC)	
16.	115-002	2	ZERK (02N90)	SEE FOOTNOTE 1

### FOOTNOTES

1. AT ASSEMBLY EACH ZERK NEEDS 20X OF MULTI PURPOSE GREASE

# CARRIAGE

JT2720 MACH 1 ONLY

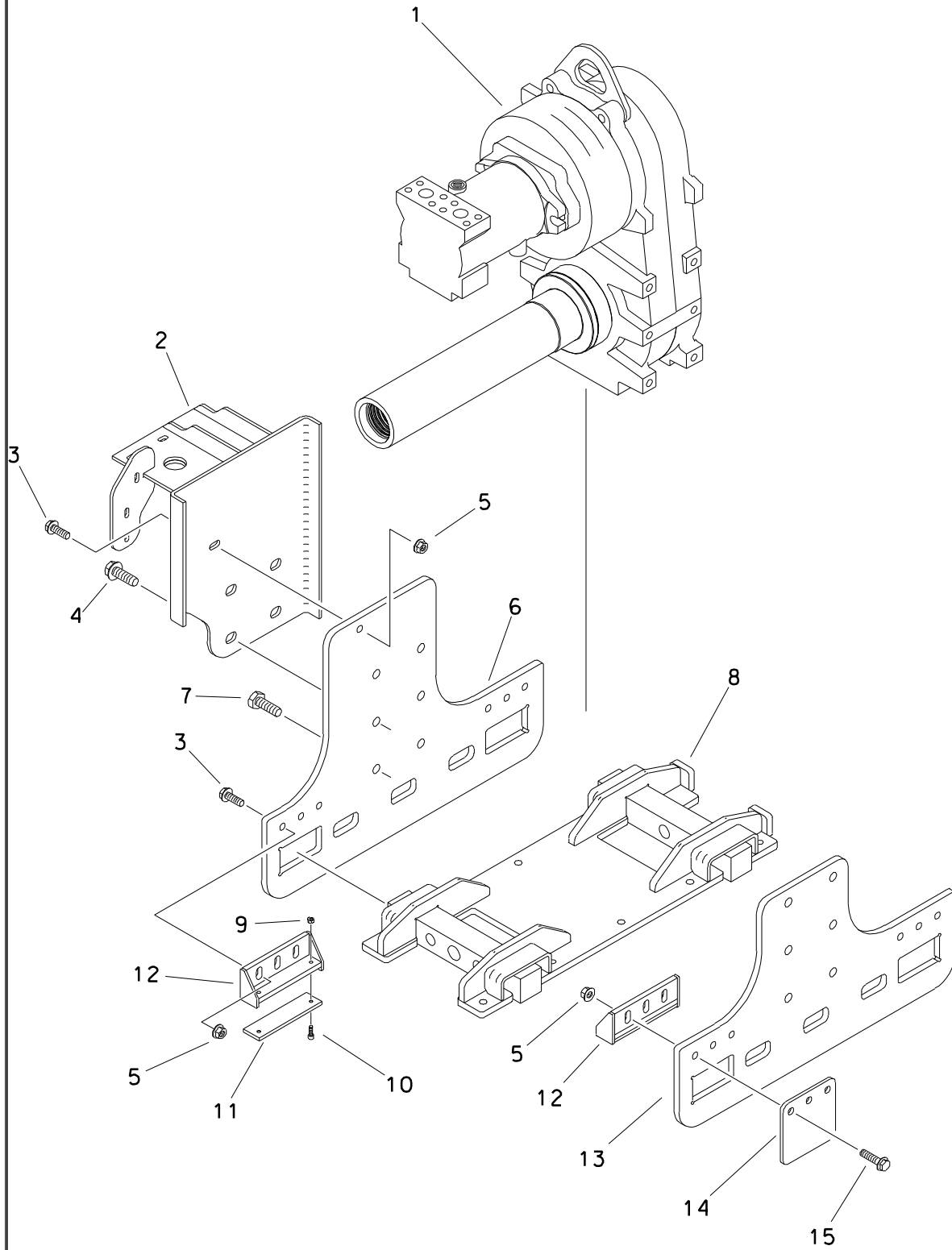

# CARRIAGE

## JT2720 MACH 1 ONLY

REF NO.	PART NUMBER	QTY	DESCRIPTION	REMARKS
1.	<del>166-272</del>	-	SPINDLE DRIVE ASS'Y	
	166-456	-	JT SPINDLE DRIVE PARTS ASS'Y	
2.	309-775	1	HOSE TRACK MOUNT	
3.	107-003	4	FLG LK SCREW (M12-1.75 X 35MM)	
4.	106-470	4	FLG SCREW (M16-2.00 X 40MM)	USE 242 LOCTITE
5.	106-354	13	FLANGE NUT (M12-1.75)	
6.	309-815	1	SIDE PLATE, RIGHT	
7.	106-478	8	SCREW (M16-2.00 X 40MM, 10.9)	USE 242 LOCTITE
8.	303-304	1	CARRIAGE WELDMENT	
9.	106-237	8	LOCKNUT (M6-1.00, PRV TRQ, NLK)	
10.	106-640	8	SCREW (M6-1.00 X 20MM, BUT SOC)	
11.	309-666	4	WEAR STRIP	
12.	309-657	4	WEAR STRIP SUPPORT	
13.	308-987	1	SIDE PLATE, LEFT	
14.	309-669	3	GUARD	
15.	107-004	9	FLG LK SCREW (M12-1.75 X 45MM)	

FOOTNOTES

# CARRIAGE

JT2720 MACH 1 ALL TERRAIN ONLY

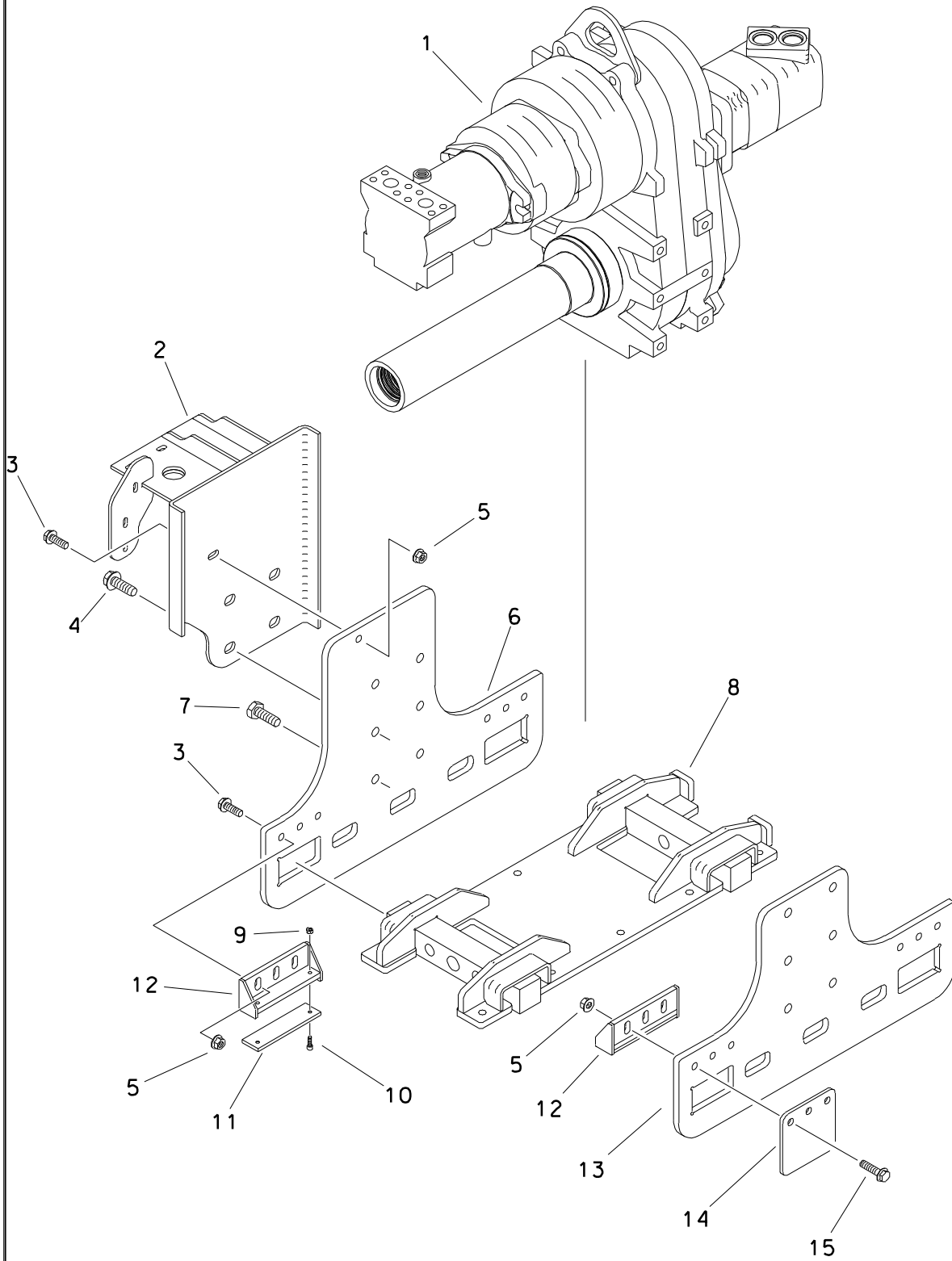

# CARRIAGE

## JT2720 MACH 1 ALL TERRAIN ONLY

REF NO.	PART NUMBER	QTY	DESCRIPTION	REMARKS
1.	166-286	-	AT2720 SPINDLE DRIVE ASS'Y	ENDS WITH S/N 2W0799
	197-090	-	REMANUFACTURED 166-286 SPNDL	
	166-368	-	SPINDL DRV PRTS ASSY, COBBLE	
	166-455	-	AT SPNDL DRV PRTS ASS'Y	BEGINS WITH S/N 2X0001
	166-457	-	SPINDL DRV PRTS ASSY, COBBLE	
2.	309-775	1	HOSE TRACK MOUNT	
3.	107-003	4	FLG LK SCREW (M12-1.75 X 35MM)	
4.	106-470	4	FLG SCREW (M16-2.00 X 40MM)	USE 242 LOCTITE
5.	106-354	13	FLANGE NUT (M12-1.75)	
6.	309-815	1	SIDE PLATE, RIGHT	
7.	106-478	8	SCREW (M16-2.00 X 40MM, 10.9)	USE 242 LOCTITE
8.	303-304	1	CARRIAGE WELDMENT	
9.	106-237	8	LOCKNUT (M6-1.00, PRV TRQ, NLK)	
10.	106-640	8	SCREW (M6-1.00 X 20MM, BUT SOC)	
11.	309-666	4	WEAR STRIP	
12.	309-657	4	WEAR STRIP SUPPORT	
13.	308-987	1	SIDE PLATE, LEFT	
14.	309-669	3	GUARD	
15.	107-004	9	FLG LK SCREW (M12-1.75 X 45MM)	

FOOTNOTES

# INTERNAL WATER SWIVEL

JT2720 MACH 1 ALL TERRAIN ONLY  
BEGINS WITH S/N 2X0001

7 8 6 9

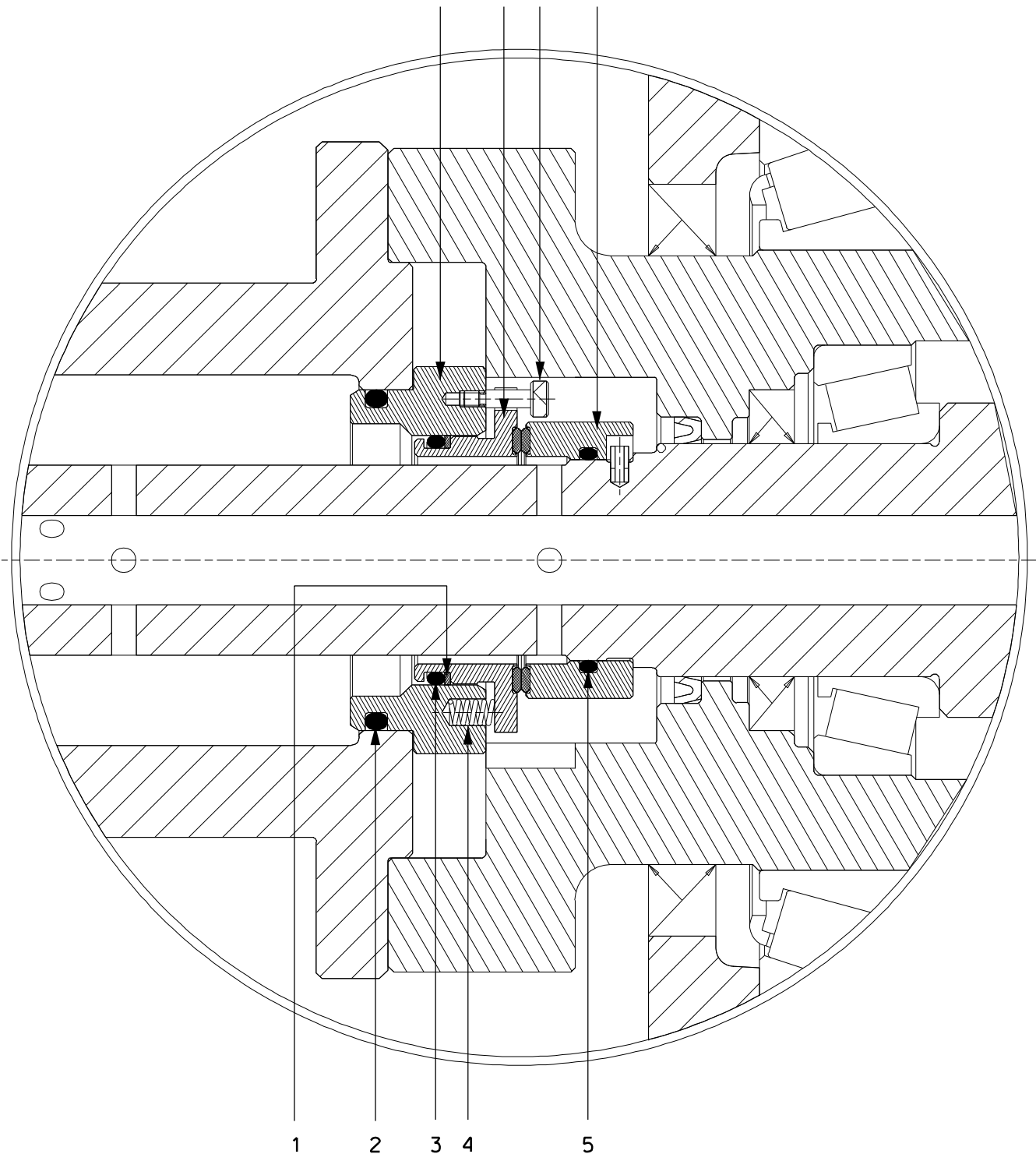

**INTERNAL WATER SWIVEL**  
**JT2720 MACH 1 ALL TERRAIN ONLY**  
**BEGINS WITH S/N 2X0001**

REF NO.	PART NUMBER	QTY	DESCRIPTION	REMARKS
	191-257	-	SEAL REPAIR KIT (157-469)	USED ONLY ON GEARBOX NUMBER 166-455 OR 166-457
1.		-	BACKUP WASHER	
2.		-	VITON O-RING	
3.		-	VITON O-RING	
4.		-	COIL SPRING	
5.		-	VITON O- RING	
6.		-	SHOULDER SCREW	
7.		-	HOUSING	
8.		-	FLOATING SEAL ASSEMBLY	
9.		-	SEAL ASSEMBLY	

FOOTNOTES

**SPINDLE DRIVE ASS'Y**  
JT2720 MACH 1 ALL TERRAIN ONLY  
ENDS WITH S/N 2W0927

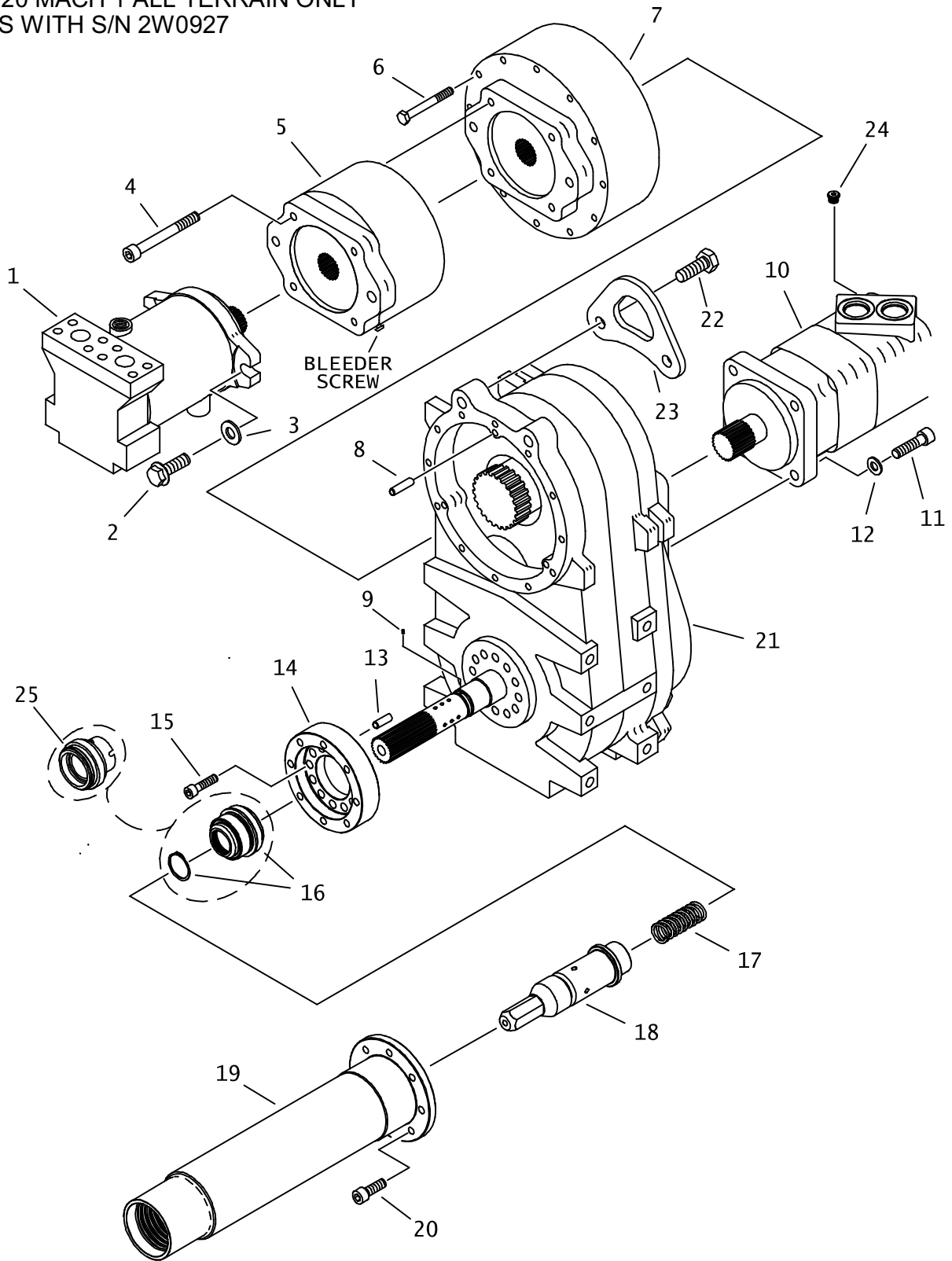



## SPINDLE DRIVE ASS'Y JT2720 MACH 1 ALL TERRAIN ONLY ENDS WITH S/N 2W0927

REF NO.	PART NUMBER	QTY	DESCRIPTION	REMARKS
	166-286	-	AT2720 SPINDLE DRIVE ASS'Y	OBSOLETE
	197-090	-	REBUILT 166-286 SPNDL DRV.	OBSOLETE SEE FOOTNOTE 2
	166-455	-	AT SPNDL DRV PRTS ASS'Y	
1.	149-970	1	HYDRAULIC MOTOR	USE RED SILICONE SEALER
2.	105-970	2	FLG BOLT (5/8-NC X 1-3/4,GD8)	USE 242 LOCTITE, TORQUE TO 200 FT LBS
3.	106-398	2	WASHER (M16, HARDENED)	
4.	107-495	4	BLT (1/2-NC X 4.50", SOC GD 8)	USE 242 LOCTITE, SEE FOOTNOTE 1.
5.	160-1099	1	MODULAR BRAKE	
	500-1283	-	OIL SEAL	
	191-166	-	O-RING KIT (160-510)	
	191-167	-	GASKET KIT (160-510)	
	191-168	-	BEARING KIT (160-510)	
	191-169	-	STACK SERVICE KIT (160-510)	
	163-212	-	BLEEDER SCREW, DISC BRAKE	
6.	105-081	12	BOLT (3/8-NC X 3-1/4")	USE 242 LOCTITE, SEE FOOTNOTE 1.
7.	166-298	1	ROTATION GEARBOX PLANETARY	
8.	105-534	3	DOWEL PIN (.375" X .875")	
9.	107-803	-	PIN .125 X .25	INCLUDED IN REF 16 & 25
10.	149-976	1	HYDRAULIC MOTOR	
	500-390	1	SEAL REPAIR KIT - REAR	
	500-391	1	SEAL REPAIR KIT - SHAFT	
	215-1061	1	SENSOR	
11.	105-869	4	BOLT (1/2-NC X 2", SOC)	USE 242 LOCTITE, SEE FOOTNOTE 1.
12.	106-397	4	WASHER (M12, HARDENED)	
13.	107-050	3	DOWEL PIN (M12 X 30MM)	OBSOLETE
14.	307-986	1	ADAPTER	
	316-894	1	ADAPTER	191-341 USED ON AT27M1 ONLY
15.	106-081	9	SCREW (M10-1.50 X 35MM, 12.9)	USE 242 LOCTITE, SEE FOOTNOTE 1.
16.	191-267	1	INNER WATER SWIVL REPLCMNT KIT	SEE FOOTNOTE 3; INCLUDES: WATER SWIVEL 153-191 & REF# 9.
	191-129	-	SEAL REPAIR KIT (153-191)	REPLACEMENT O-RING KIT; NOT INCLUDED IN 191-267
17.	117-300	1	SPRING	
18.	308-885	1	HEX STUB	
19.	400-1226	1	SAVER SUB, AT27M1	
	400-1225	1	SAVER SUB, AT27M1 COBBLE	
20.	106-797	8	SCREW (M12-1.75 X 35MM, SOC)	SEE FOOTNOTE 1.
21.	166-286	-	AT2720 GEARBOX	REFER TO PARTS PAGE 807-408
22.	106-478	2	SCREW (M16-2.00 X 40MM, 10.9)	
23.	310-965	1	LIFT BRACKET	
24.	154-384	1	PLUG (06S)	
25.	191-341	1	INNER WATER SWIVL REPLCMNT KIT	SEE FOOTNOTE 4; INCLUDES: WATER SWIVEL 157-469 & REF #9.
	191-257	-	SEAL REPAIR KIT (157-469)	REPLACEMENT O-RING KIT; NOT INCLUDED IN 191-341

NOT SHOWN:

### FOOTNOTES:

- REFER TO TORQUE CHART IN BACK OF MANUAL.
- INCLUDES REF. #'S 13-21, DOES NOT INCLUDE REF. #'S 1-12, 22 & 23. A GEARBOX COVER 314-382 IS INSTALLED TO PREVENT CONTAMINATION, IT SHOULD BE REINSTALLED ON RETURN GEARBOX.
- USED ON 166-286 & 197-090 WITH A 166-270 INNER SHAFT. INCLUDES 166-455.
- USED ON 197-090 WITH A 166-444 INNER SHAFT.

NOTE:

**SPINDLE DRIVE ASS'Y**  
 JT2720 MACH 1 ALL TERRAIN ONLY  
 BEGINS WITH S/N 2X0001

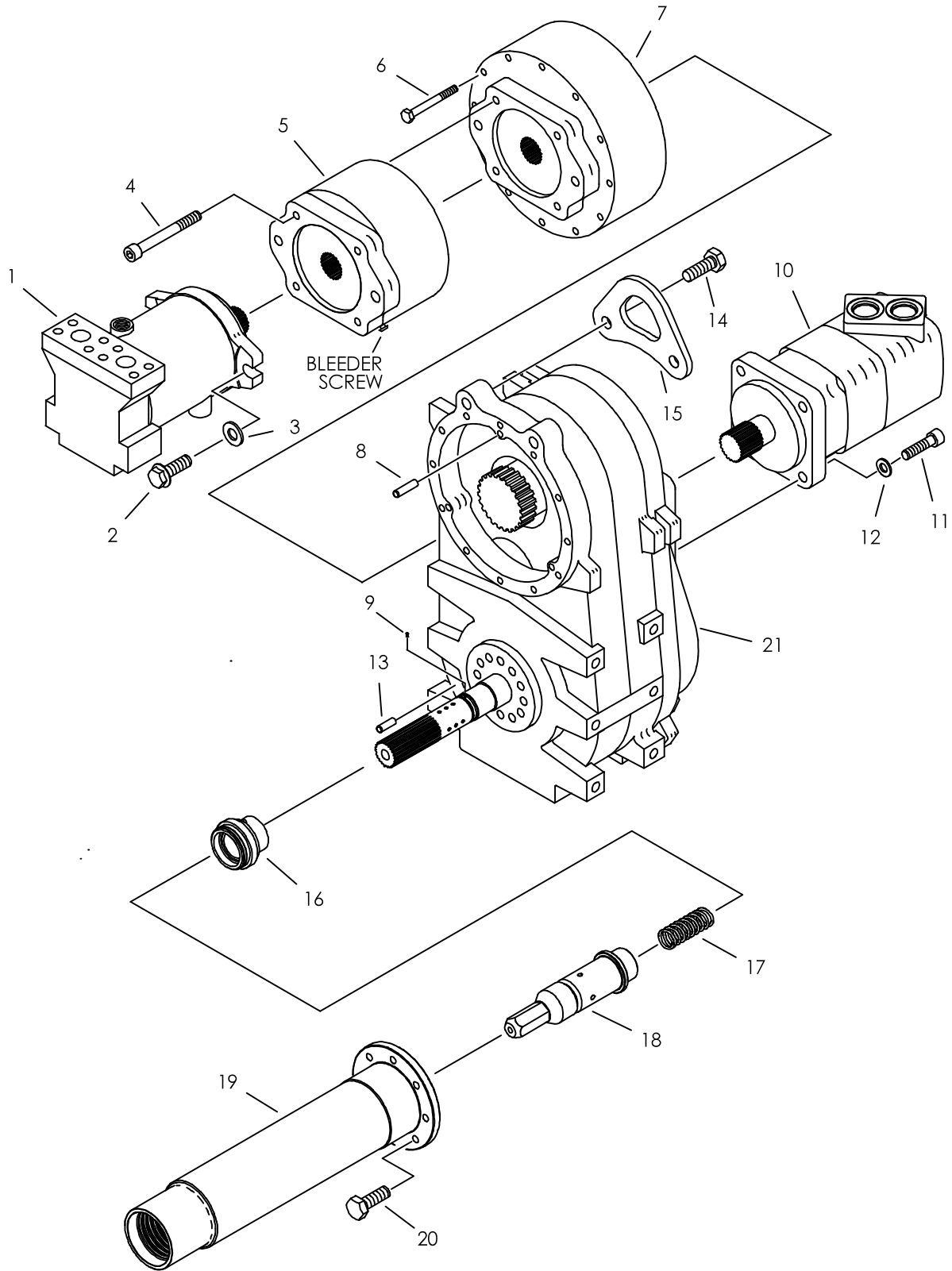

**SPINDLE DRIVE ASS'Y**  
**JT2720 MACH 1 ALL TERRAIN ONLY**  
**BEGINS WITH S/N 2X0001**

REF NO.	PART NUMBER	QTY	DESCRIPTION	REMARKS
	166-455	-	AT SPNDL DRV PRYS ASS'Y	BEGINS WITH S/N 2X0001
	166-457	-	SPINDL DRV PRYS ASSY, COBBLE	
1.	149-970	1	HYDRAULIC MOTOR	USE RED SILICONE SEALER
2.	105-970	2	FLG BOLT (5/8-NC X 1.75",GD8)	USE 242 LOCTITE, TORQUE TO 200 FT LBS
3.	106-398	2	WASHER (M16, HARDENED)	
4.	107-495	4	BLT (1/2-NC X 4.50", SOC GD 8)	USE 242 LOCTITE, SEE FOOTNOTE
5.	160-1099	1	MODULAR BRAKE	
	500-1283	-	OIL SEAL	
	191-166	-	O-RING KIT (160-510)	
	191-167	-	GASKET KIT (160-510)	
	191-168	-	BEARING KIT (160-510)	
	191-169	-	STACK SERVICE KIT (160-510)	
	163-212	-	BLEEDER SCREW, DISC BRAKE	
6.	105-179	12	BOLT (3/8-NC X 3-1/2")	USE 242 LOCTITE, SEE FOOTNOTE
7.	166-298	1	ROTATION GEARBOX PLANETARY	
8.	105-534	3	DOWEL PIN (.375" X .875")	
9.	107-803	1	PIN .125 X .25	
10.	149-976	1	HYDRAULIC MOTOR	
	500-390	1	SEAL REPAIR KIT - REAR	
	500-391	1	SEAL REPAIR KIT - SHAFT	
	215-1061	1	SENSOR	
11.	105-869	4	BOLT (1/2-NC X 2", SOC)	USE 242 LOCTITE, SEE FOOTNOTE
12.	106-397	4	WASHER (M12, HARDENED)	
13.	500-818	2	DOWEL PIN (16MM X 40MM)	
14.	106-478	2	SCREW (M16-2.00 X 40MM, 10.9)	
15.	310-965	1	LIFT BRACKET	
16.	157-469	1	WATER SWIVEL SEAL ASS'Y	
	191-257	-	SEAL REPAIR KIT (157-469)	REPLACEMENT O-RING KIT
17.	117-300	1	SPRING	
18.	319-443	1	HEX STUB	USE WITH OLD STYLE PIPE
	400-1501	1	HEX STUB	USE WITH COLLARED PIPE
19.	400-1227	1	SAVER SUB 2.77-4F DS	BEGINS WITH S/N 2X0001
	400-1228	1	SAVER SUB 2.77-4F SS	
20.	106-478	8	SCREW (M16-2.00 X 40MM, 10.9)	SEE FOOTNOTE
21.	166-286	-	AT2720 GEARBOX	REFER TO PARTS PAGE 807-408

NOT SHOWN:

FOOTNOTES:

1. REFER TO TORQUE CHART IN BACK OF PARTS BOOK.

NOTE:

**SPINDLE DRIVE ASS'Y**  
JT2720 MACH 1 ONLY  
ENDS WITH S/N: 2W9999

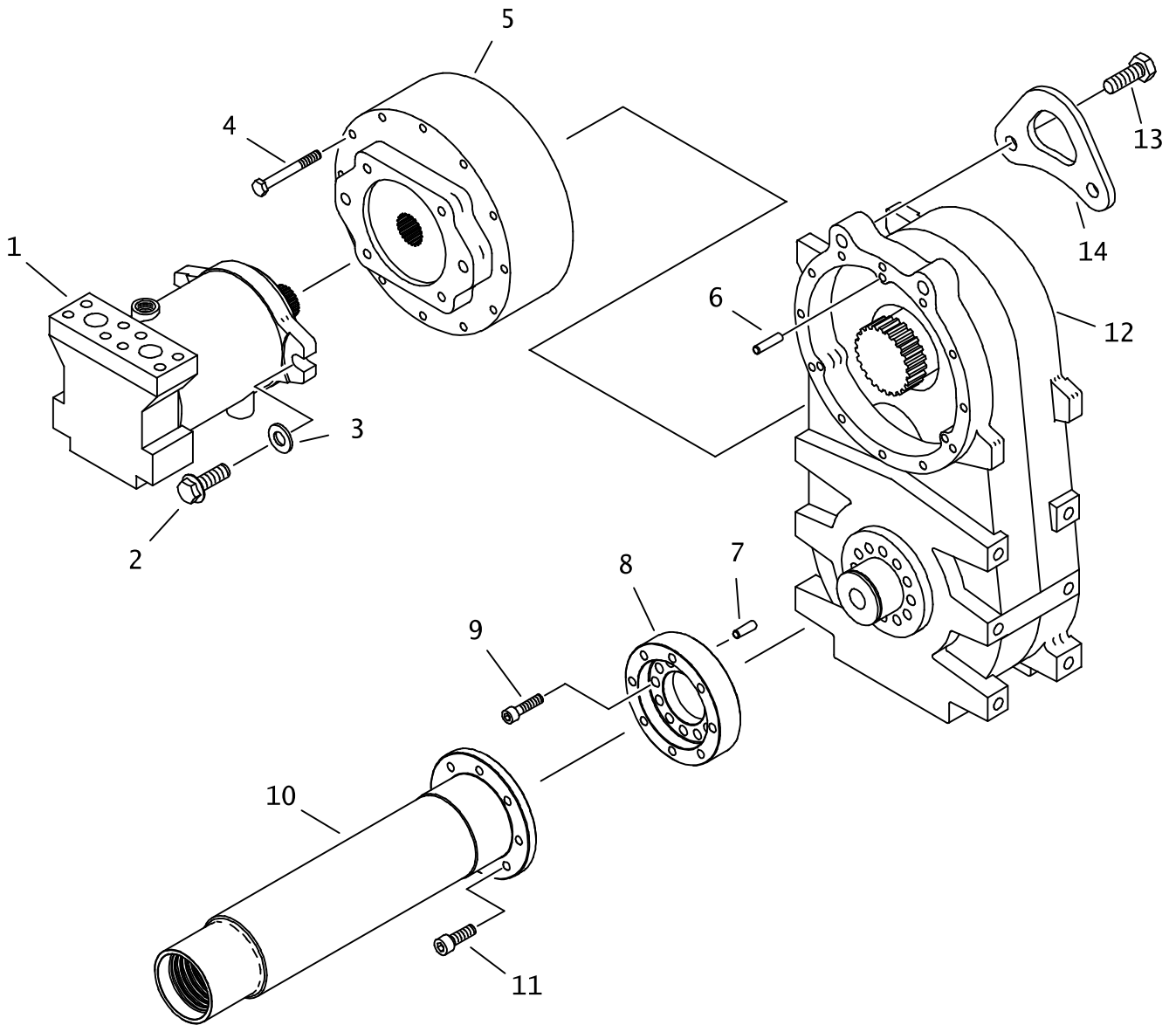

**SPINDLE DRIVE ASS'Y**  
**JT2720 MACH 1 ONLY**  
**ENDS WITH S/N: 2W9999**

REF NO.	PART NUMBER	QTY	DESCRIPTION	REMARKS
1.	149-970	1	HYDRAULIC MOTOR	
2.	105-970	2	FLG BOLT (5/8-NC X 1.750",GD8)	USE 242 LOCTITE, TORQUE TO 200 FT LBS
3.	106-398	2	WASHER (M16, HARDENED)	
4.	105-081	12	BOLT (3/8-NC X 3-1/4")	USE 242 LOCTITE, SEE FOOTNOTE
5.	166-298	1	ROTATION GEARBOX PLANETARY	
6.	105-534	3	DOWEL PIN (.375" X .875")	
7.	107-050	3	PRECISION DOWEL PIN (M12 X 30)	
8.	<u>307-986</u>	1	ADAPTER	
	316-894	1	ADAPTER	
9.	106-081	9	SCREW (M10-1.50 X 35MM, 12.9)	USE 242 LOCTITE, SEE FOOTNOTE
10.	400-1224	1	SAVER SUB JT27M1	
11.	106-797	8	SCREW (M12-1.75 X 35MM, SOC)	SEE FOOTNOTE
12.	<u>166-272</u>	-	SPINDLE DRIVE ASS'Y	
	166-456	-	JT SPINDLE DRIVE PARTS ASS'Y	
13.	106-478	2	SCREW (M16-2.00 X 40MM, 10.9)	
14.	310-965	1	LIFT BRACKET	

NOT SHOWN:

FOOTNOTES:

REFER TO TORQUE CHART IN BACK OF PARTS BOOK .

NOTE:

**SPINDLE DRIVE ASS'Y**  
JT2720 MACH 1 ONLY  
BEGINS WITH S/N: 2X0001

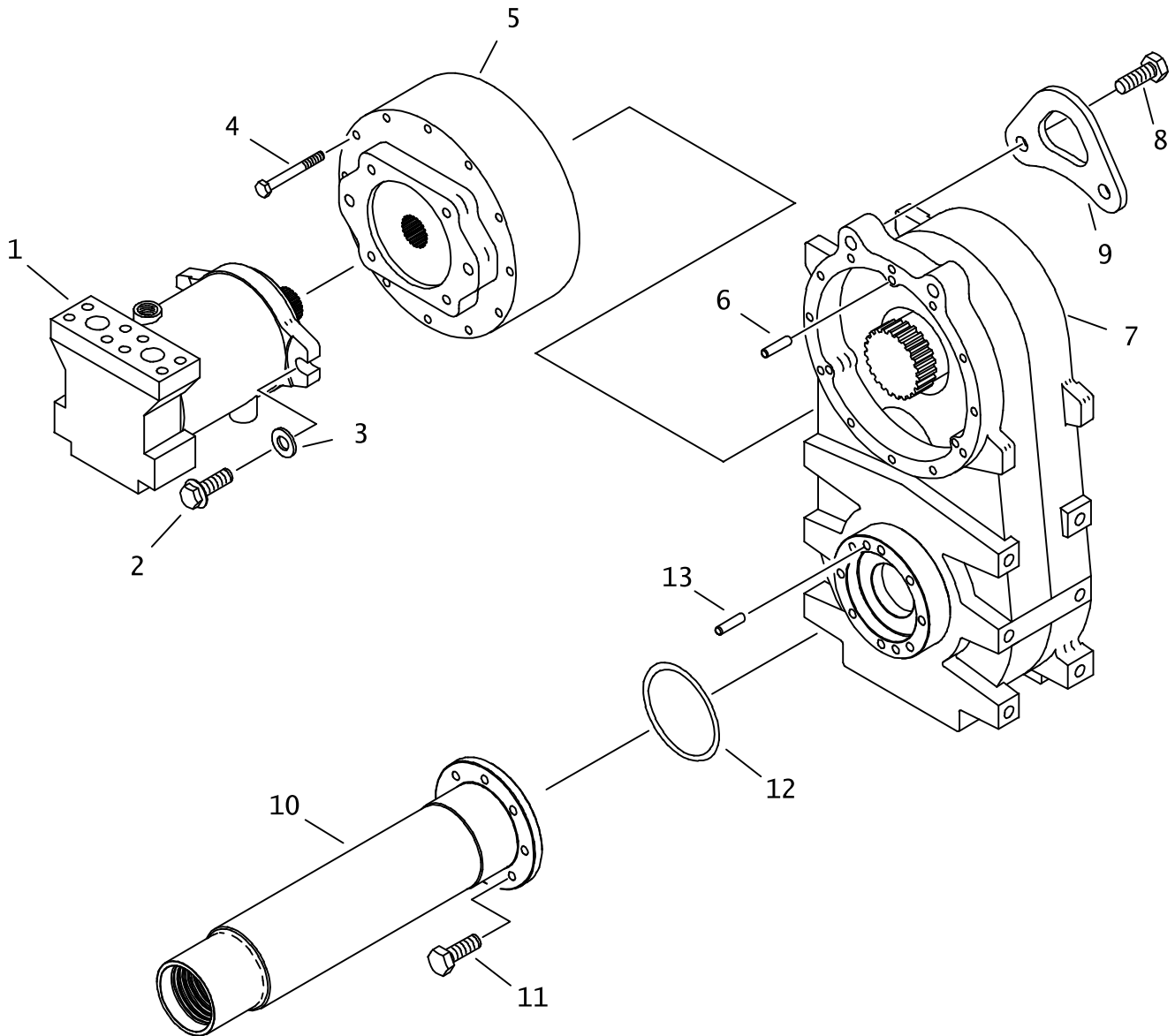

**SPINDLE DRIVE ASS'Y**  
**JT2720 MACH 1 ONLY**  
**BEGINS WITH S/N: 2X0001**

REF NO.	PART NUMBER	QTY	DESCRIPTION	REMARKS
1.	149-970	1	HYDRAULIC MOTOR	
2.	105-970	2	FLG BOLT (5/8-NC X 1.750",GD8)	USE 242 LOCTITE, TORQUE TO 200 FT LBS
3.	106-398	2	WASHER (M16, HARDENED)	
4.	105-179	12	BOLT (3/8-NC X 3-1/2")	USE 242 LOCTITE, SEE FOOTNOTE
5.	166-298	1	ROTATION GEARBOX PLANETARY	
6.	105-534	3	DOWEL PIN (.375" X .875")	
7.	166-456	-	JT SPINDLE DRIVE PARTS ASS'Y	
8.	106-478	2	SCREW (M16-2.00 X 40MM, 10.9)	
9.	310-965	1	LIFT BRACKET	
10.	400-1229	1	SAVER SUB 2.11-4F DS	
11.	106-478	8	SCREW (M16-2.00 X 40MM, 10.9)	USE 242 LOCTITE, SEE FOOTNOTE
12.	155-726	1	O-RING (329 D70)	
13.	500-818	2	DOWEL PIN (16MM X 40MM)	

NOT SHOWN:

FOOTNOTES:

REFER TO TORQUE CHART IN BACK OF PARTS BOOK .

NOTE:

ROTATION GEARBOX  
JT2720 MACH 1 ONLY  
ENDS WITH S/N

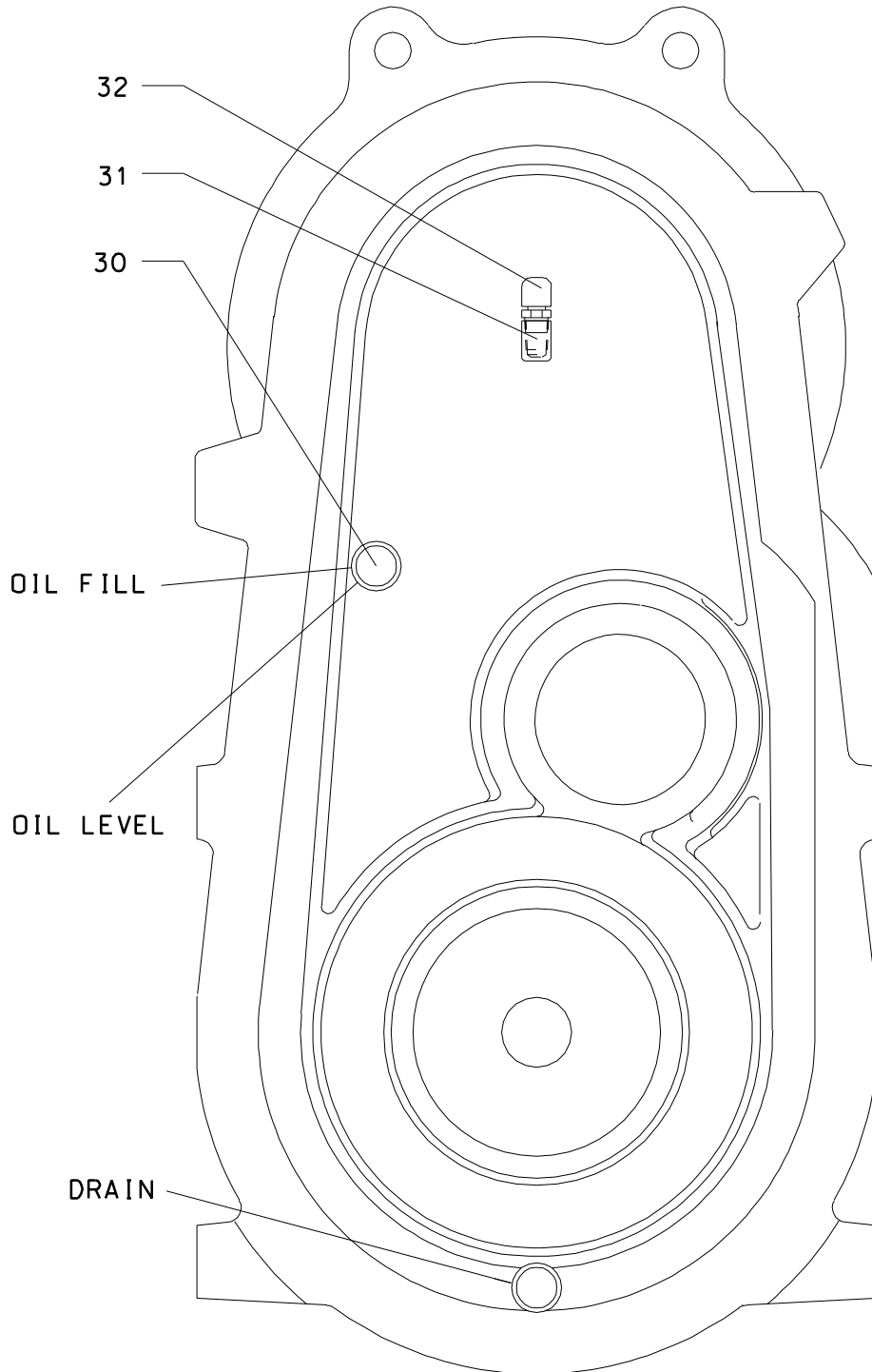



ROTATION GEARBOX  
 JT2720 MACH 1 ONLY  
 ENDS WITH S/N

REF NO.	PART NUMBER	QTY	DESCRIPTION	REMARKS
1.	107-578	1	SHIM	
2.	107-577	1	SHIM	
3.	107-576	1	SHIM	
4.	125-309	1	TAPERED RACE (5.000")	
5.	125-308	1	TAPERED BEARING (3.000")	
6.	168-034	1	INPUT PINION	
7.	164-007	1	HOUSING	
8.	107-050	5	PRECISION DOWEL PIN (M12 X 30)	
9.	307-901	1	COVER	
10.	125-359	1	TAPERED RACE (4.781")	
11.	125-360	1	TAPERED BEARING (3.000")	
12.	165-869	1	SHIM (.051MM)	
13.	165-868	1	SHIM (.076MM)	
14.	165-870	1	SHIM (.178MM)	
15.	168-035	1	IDLER GEAR	
16.	126-171	2	TAPERED RACE (3.740")	
17.	126-170	2	TAPERED BEARING (2.250")	
18.	165-842	1	SHIM (.051MM)	
19.	165-843	1	SHIM (.076MM)	
20.	165-844	1	SHIM (.178MM)	
21.	174-025	1	OUTPUT GEAR	
22.	126-063	2	TAPERED RACE (6.496")	
23.	126-064	2	TAPERED BEARING (4.330")	
24.	165-803	1	SHIM (.0002")	
25.	165-804	1	SHIM (.003")	
26.	165-805	1	SHIM (.007")	
27.	157-631	2	INTERNAL SEAL (4.250")	
28.	166-269	1	OUTPUT SHAFT	
29.	106-617	14	SCREW (M10-1.50 X 80MM)	
30.	115-211	2	PLUG (O8N, SQ, MAG)	
31.	514-123	1	PICKUP TUBE (O2N-O2NF90-2")	
32.	159-003	1	AIR VENT (O2N)	
33.	106-396	14	WASHER (M10, HARDENED)	
34.	155-726	1	O-RING (329 D70)	

FOOTNOTES

ROTATION GEARBOX  
JT2720 MACH 1 ONLY  
ENDS WITH S/N

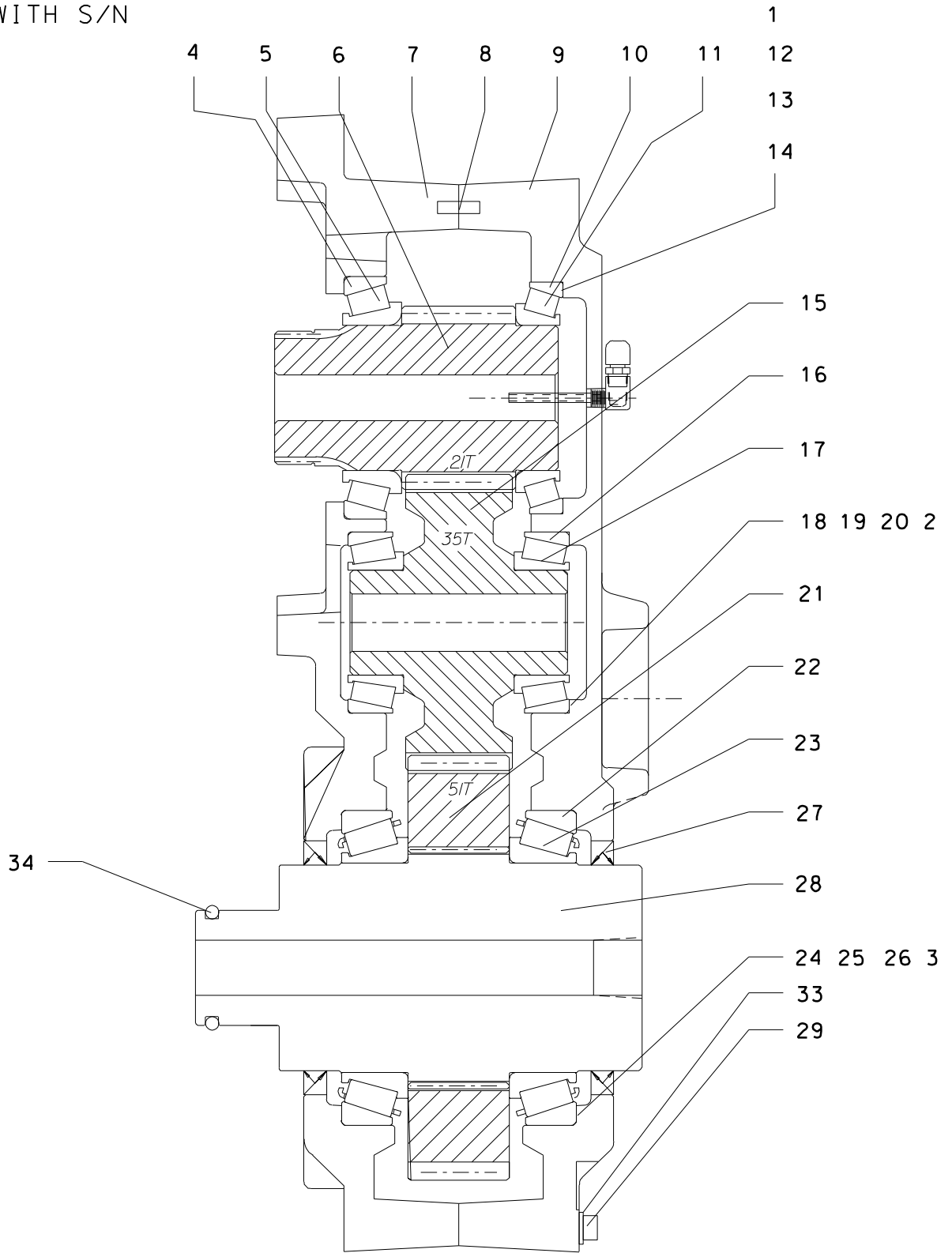



**ROTATION GEARBOX**  
JT2720 MACH 1 ONLY  
BEGINS WITH S/N:

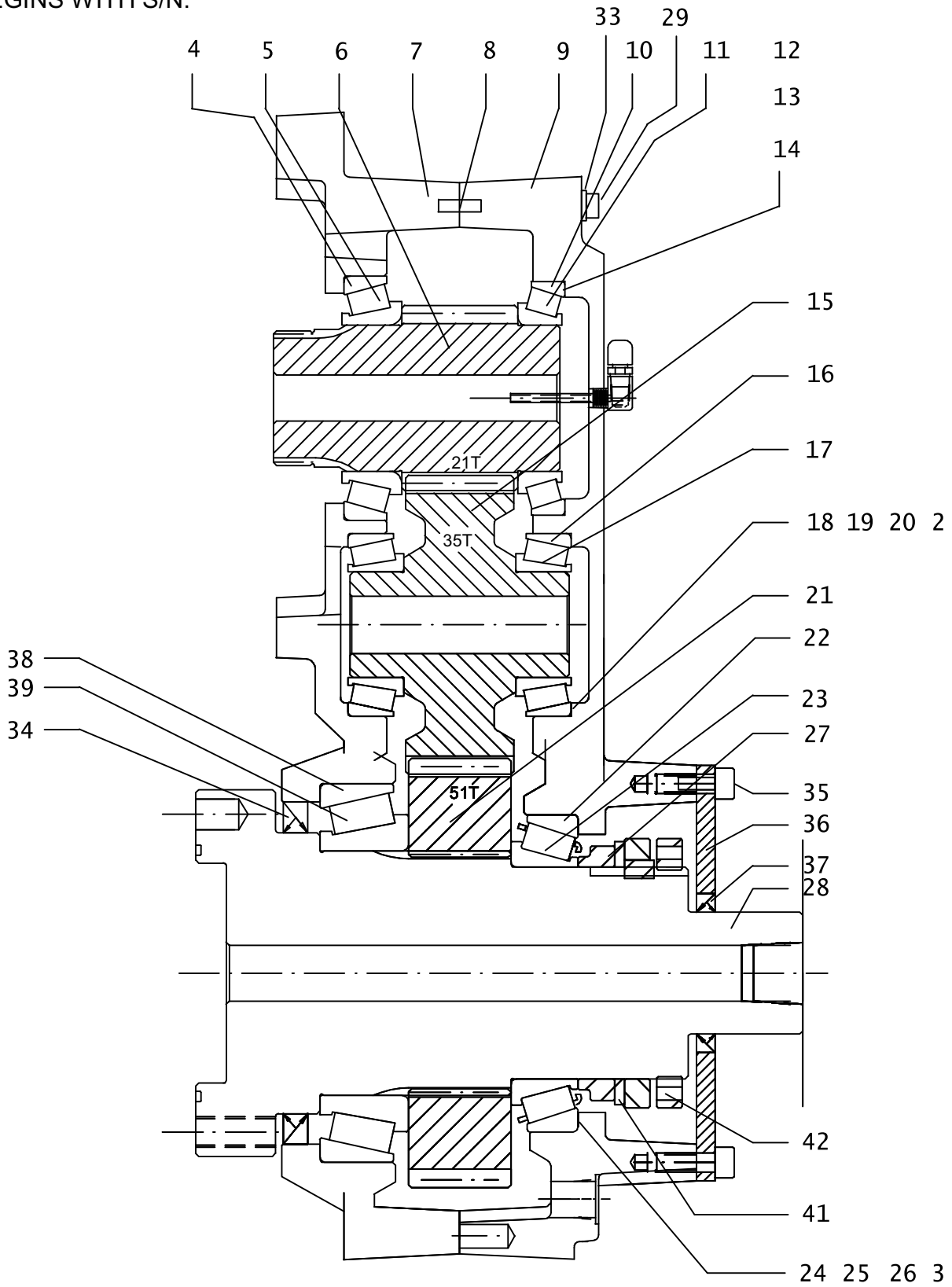

**ROTATION GEARBOX**  
JT2720 MACH 1 ONLY  
BEGINS WITH S/N:

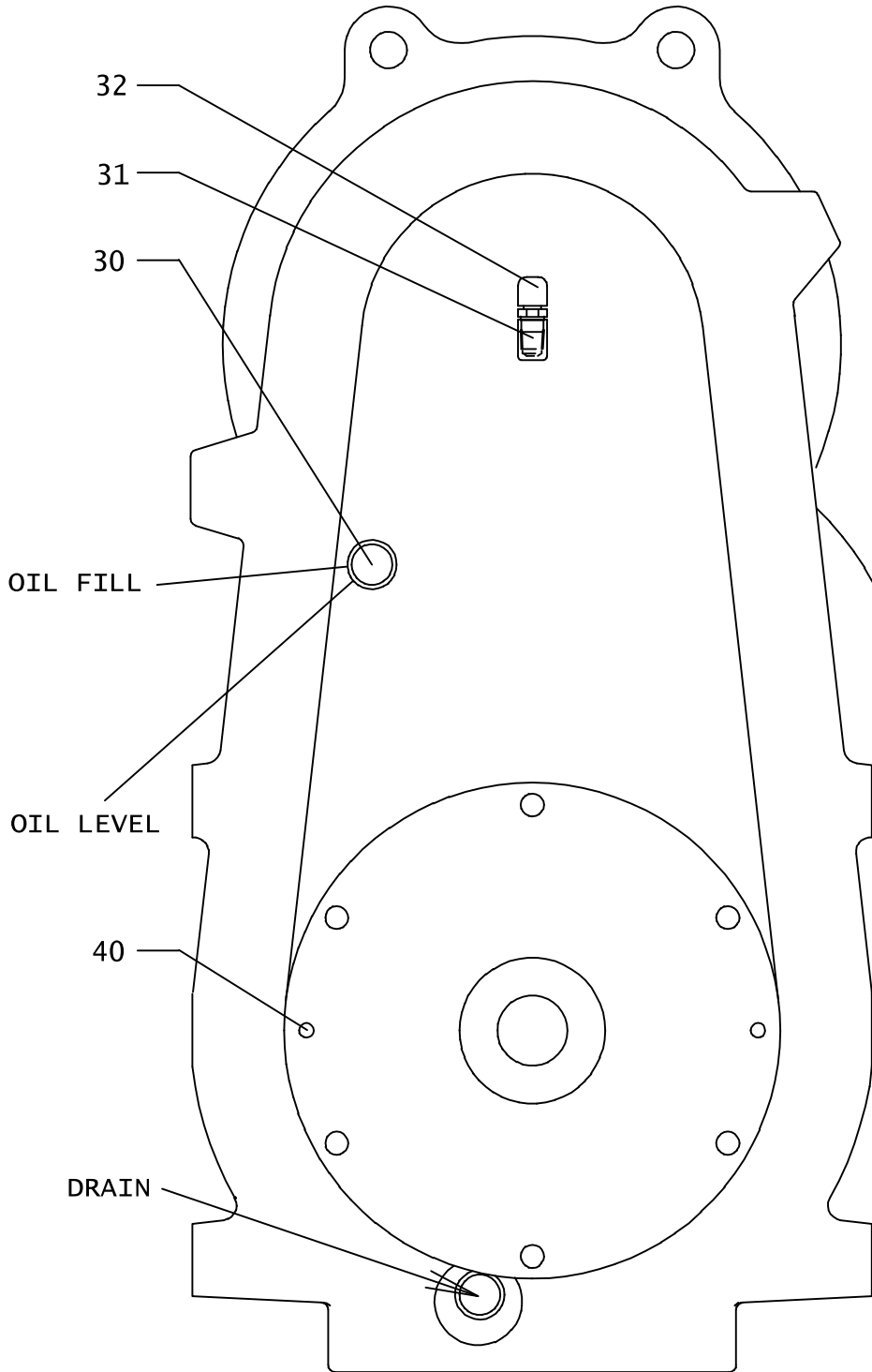

# ROTATION GEARBOX

JT2720 MACH 1 ONLY

BEGINS WITH S/N:

REF NO.	PART NUMBER	QTY	DESCRIPTION	REMARKS
	166-456	-	JT SPINDLE DRIVE PARTS ASS'Y	
1.	107-578	1	SHIM	
2.	107-577	1	SHIM	
3.	107-576	1	SHIM	
4.	125-309	1	TAPERED RACE (5.000")	
5.	125-308	1	TAPERED BEARING (3.000")	
6.	168-034	1	INPUT PINION	
7.	164-028	1	HOUSING	
8.	107-050	2	PRECISION DOWEL PIN (M12 X 30)	
9.	164-029	1	HOUSING	
10.	125-359	1	TAPERED RACE (4.781")	
11.	125-360	1	TAPERED BEARING (3.000")	
12.	165-869	1	SHIM (.051MM)	
13.	165-868	1	SHIM (.076MM)	
14.	165-870	1	SHIM (.178MM)	
15.	168-035	1	IDLER GEAR	
16.	126-171	2	TAPERED RACE (3.740")	
17.	126-170	2	TAPERED BEARING (2.250")	
18.	165-842	1	SHIM (.051MM)	
19.	165-843	1	SHIM (.076MM)	
20.	165-844	1	SHIM (.178MM)	
21.	174-025	1	OUTPUT GEAR	
22.	126-063	1	TAPERED RACE (6.496")	
23.	126-064	1	TAPERED BEARING (4.330")	
24.	165-803	1	SHIM (.0002")	
25.	165-804	1	SHIM (.003")	
26.	165-805	1	SHIM (.007")	
27.	300-7825	1	SPACER	
28.	166-453	1	OUTPUT SHAFT	
29.	106-617	14	SCREW (M10-1.50 X 80MM)	
30.	115-211	2	PLUG (08N, SQ, MAG)	
31.	514-123	1	PICKUP TUBE (02N-02NF90-2")	
32.	159-003	1	AIR VENT (02N)	
33.	106-396	14	WASHER (M10, HARDENED)	
34.	153-615	1	INTERNAL SEAL (5.750" ID)	
35.	106-755	6	SCREW (M10-1.50 X 30MM, SOC)	
36.	318-459	1	COVER	
37.	153-638	1	INTERNAL SEAL	
38.	125-543	1	TAPERED RACE (7.75)	
39.	125-542	1	TAPERED BEARING	
40.	105-580	2	ROLL PIN (1/4" X 3/4")	
41.	105-1313	1	HARDEND WASHER	
42.	107-706	1	NUT, SPANNER	
	190-1386	1	GEARBOX NUT	
	255-1006	-	MOLLY PASTE (SINGLE APPLICATION)	

NOT SHOWN:

FOOTNOTES:

NOTE:



# ROTATION GEARBOX

JT2720 MACH 1 ALL TERRAIN ONLY  
 ENDS WITH S/N 2W0927

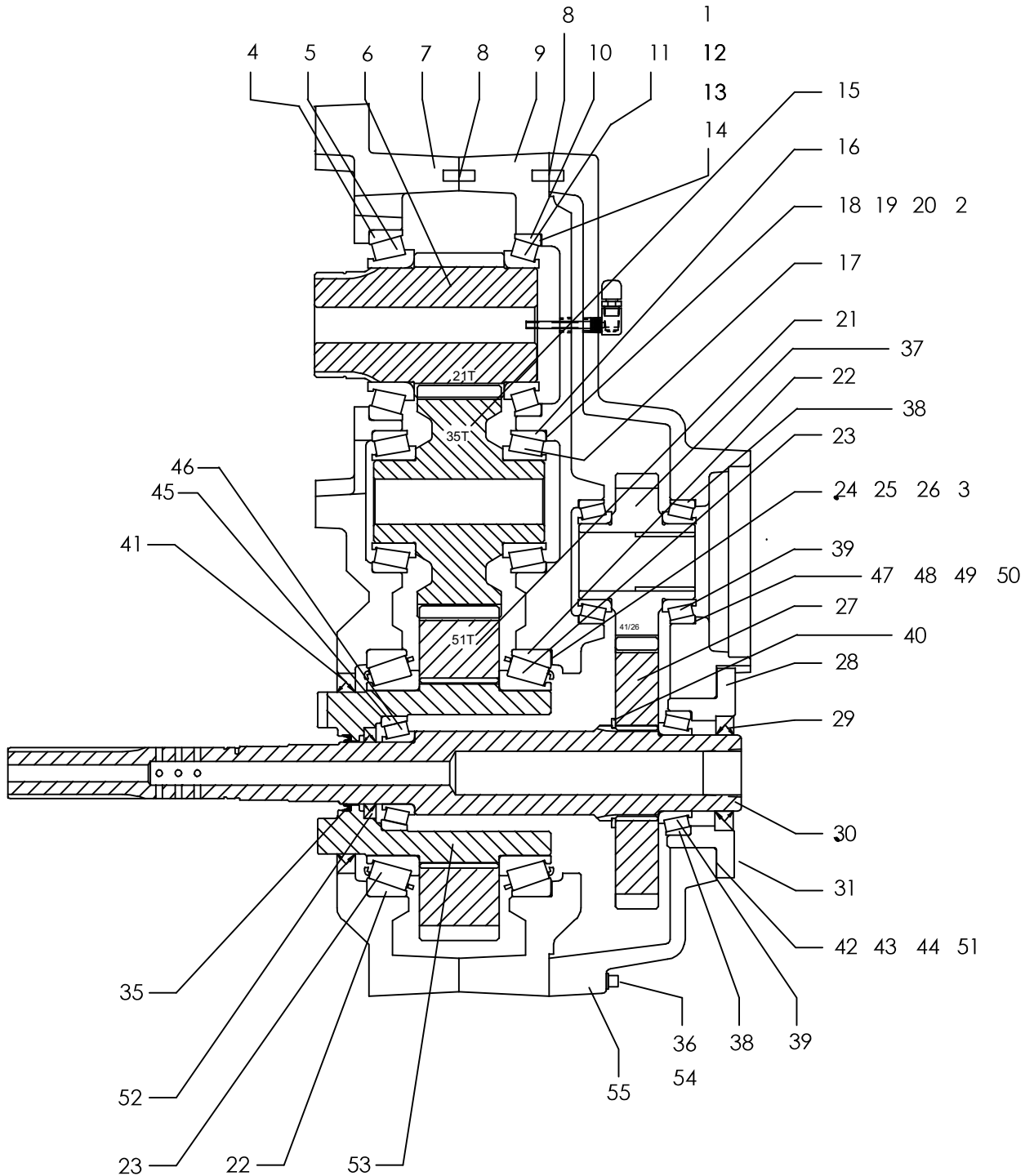



# ROTATION GEARBOX

JT2720 MACH 1 ALL TERRAIN ONLY  
ENDS WITH S/N 2W0927

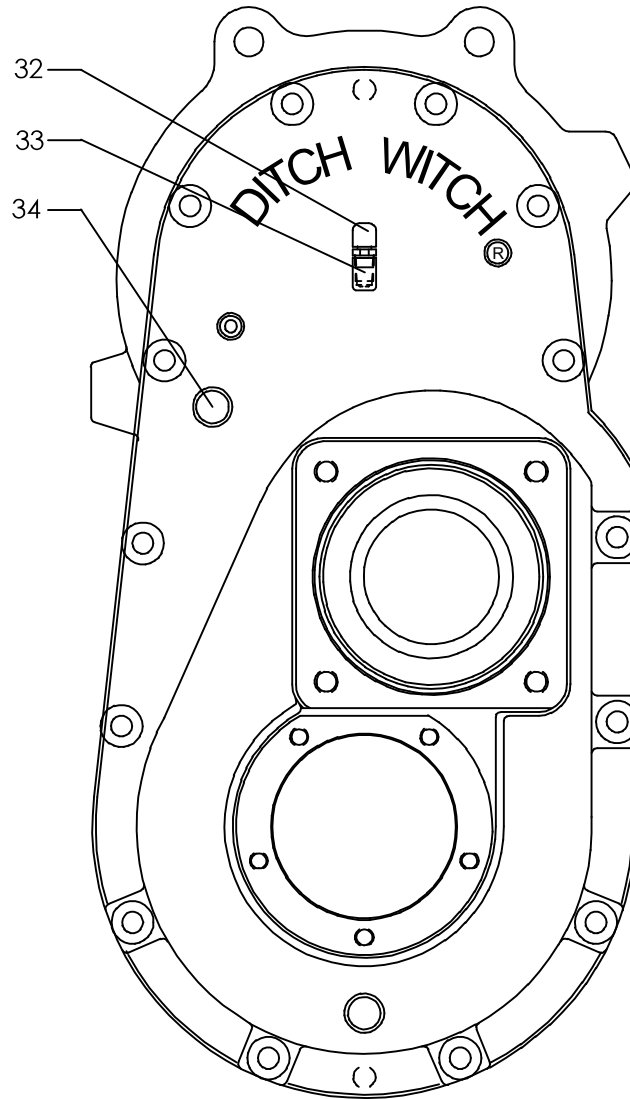

## ROTATION GEARBOX

JT2720 MACH 1 ALL TERRAIN ONLY  
ENDS WITH S/N 2W0927

REF	PART				REMARKS
NO.	NUMBER	QTY	DESCRIPTION		
	166-286	1	AT2720 SPINDLE DRIVE ASS'Y		OBSOLETE
	166-455	1	AT SPNDL DRV PRTS ASS'Y		
1.	107-578	1	SHIM (.020")		
2.	107-577	1	SHIM (.020")		
3.	107-576	1	SHIM (.020")		
4.	125-308	1	TAPERED BEARING (3.000")		
5.	125-309	1	TAPERED RACE (5.000")		
6.	168-034	1	INPUT PINION		
7.	164-007	1	HOUSING		OBSOLETE
8.	107-050	7	PRECISION DOWEL PIN (M12 X 30MM)		
9.	307-901	1	COVER		OBSOLETE
10.	125-359	1	TAPERED RACE (4.781")		
11.	125-360	1	TAPERED BEARING (3.000")		
12.	165-869	1	SHIM (.051MM)		
13.	165-868	1	SHIM (.076MM)		
14.	165-870	1	SHIM (.178MM)		
15.	168-035	1	IDLER GEAR		
16.	126-171	2	TAPERED RACE (3.740")		
17.	126-170	2	TAPERED BEARING (2.250")		
18.	165-842	1	SHIM (.051MM)		
19.	165-843	1	SHIM (.076MM)		
20.	165-844	1	SHIM (.178MM)		
21.	174-025	1	OUTPUT GEAR		
22.	126-063	2	TAPERED RACE (6.496")		
23.	126-064	2	TAPERED BEARING (4.330")		
24.	165-803	1	SHIM (.002")		
25.	165-804	1	SHIM (.003")		
26.	165-805	1	SHIM (.007")		
27.	174-026	1	INNER GEAR		
28.	178-438	1	BEARING RETAINER		
29.	157-501	1	INTERNAL SEAL		
30.	166-270	1	INNER SHAFT		OBSOLETE
	166-444	1	INNER SHAFT		
	191-341	1	INNER WATER SWIVL REPLCMNT KIT		NOT SHOWN
	316-894	1	ADAPTER		NOT SHOWN
31.	106-755	5	SCREW (M10-1.50 X 30MM, SOC)		
32.	159-003	1	AIR VENT (02N)		
33.	514-123	1	PICKUP TUBE (02N-02NF90-2")		
34.	115-211	2	PLUG (08N, SQ, MAG)		
35.	149-927	1	INTERNAL SEAL		
36.	106-805	14	SCREW (M10-1.50 X 120MM, SOC)		
37.	166-271	1	INNER PINION		
38.	126-099	3	TAPERED RACE (3.25")		

FOOTNOTES

NOTE:

## ROTATION GEARBOX

JT2720 MACH 1 ALL TERRAIN ONLY  
ENDS WITH S/N 2W0927

REF NO.	PART NUMBER	QTY	DESCRIPTION	REMARKS
39.	126-100	3	TAPERED BEARING (2")	
40.	115-457	1	EXTERNAL SNAP RING (2.5")	
41.	157-631	1	INTERNAL SEAL (4.250")	
42.	107-485	1	SHIM (.002")	
43.	107-486	1	SHIM (.003")	
44.	107-487	1	SHIM (.007")	
45.	125-249	1	BEARING RACE	
46.	125-248	1	BEARING	
47.	165-800	1	SHIM (.002")	
48.	165-801	1	SHIM (.003")	
49.	165-802	1	SHIM (.007")	
50.	107-575	1	SHIM (.020")	
51.	107-579	1	SHIM (.020")	
52.	153-153	1	SEAL	
53.	166-268	1	OUTPUT SHAFT	
54.	106-396	14	WASHER (M10, HARDENED)	
55.	307-904	1	MOTOR COVER	

FOOTNOTES

NOTE:

G

807-408

**ROTATION GEARBOX**  
JT2720 MACH 1 ALL TERRAIN ONLY  
BEGINS WITH S/N: 2X0001

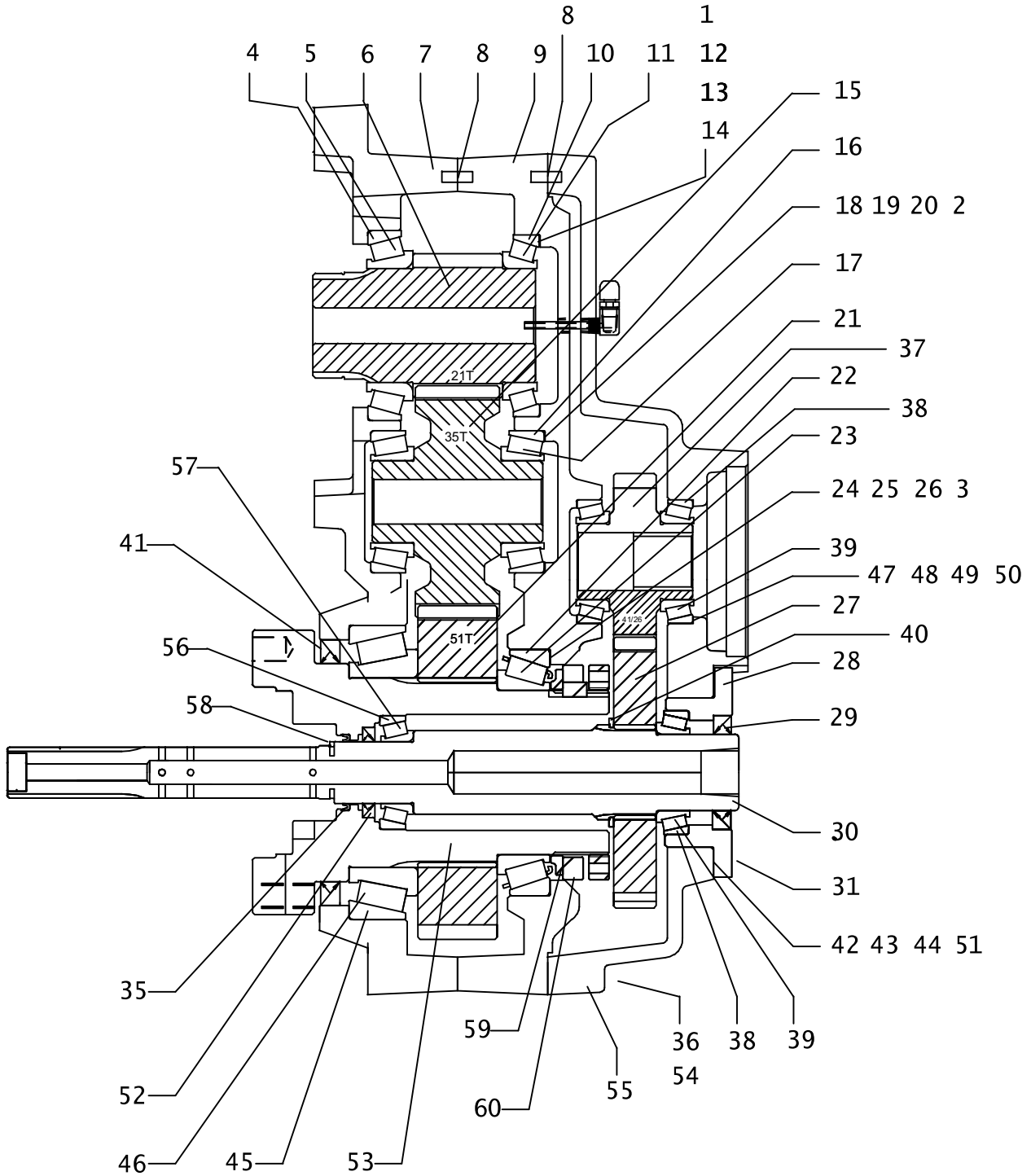

**ROTATION GEARBOX**  
JT2720 MACH 1 ALL TERRAIN ONLY  
BEGINS WITH S/N: 2X0001

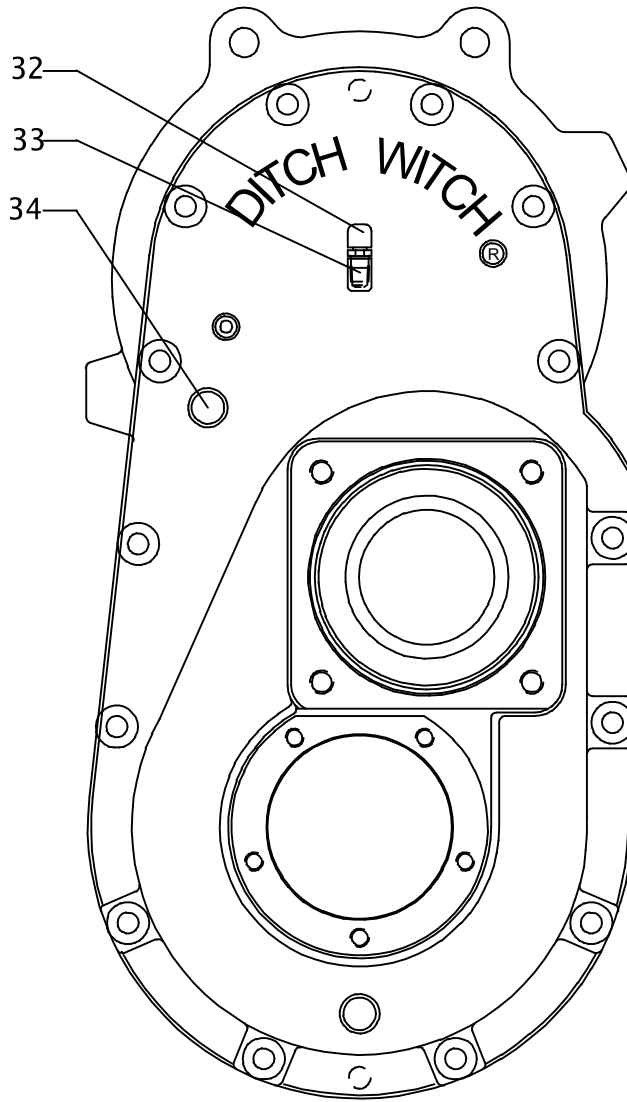

**ROTATION GEARBOX**  
**JT2720 MACH 1 ALL TERRAIN ONLY**  
**BEGINS WITH S/N: 2X0001**

REF NO.	PART NUMBER	QTY	DESCRIPTION	REMARKS
	166-455	-	AT SPNDL DRV PRTS ASS'Y	
	166-457	-	SPINDL DRV PRTS ASSY, COBBLE	
1.	107-578	1	SHIM	
2.	107-577	1	SHIM	
3.	107-576	1	SHIM	
4.	125-308	1	TAPERED BEARING (3.000")	
5.	125-309	1	TAPERED RACE (5.000")	
6.	168-034	1	INPUT PINION	
7.	164-028	1	HOUSING	
8.	107-050	4	PRECISION DOWEL PIN (M12 X 30)	
9.	318-608	1	COVER	
10.	125-359	1	TAPERED RACE (4.781")	
11.	125-360	1	TAPERED BEARING (3.000")	
12.	165-869	1	SHIM (.051MM)	
13.	165-868	1	SHIM (.076MM)	
14.	165-870	1	SHIM (.178MM)	
15.	168-035	1	IDLER GEAR	
16.	126-171	2	TAPERED RACE (3.740")	
17.	126-170	2	TAPERED BEARING (2.250")	
18.	165-842	1	SHIM (.051MM)	
19.	165-843	1	SHIM (.076MM)	
20.	165-844	1	SHIM (.178MM)	
21.	174-025	1	OUTPUT GEAR	
22.	126-063	1	TAPERED RACE (6.496")	
23.	126-064	1	TAPERED BEARING (4.330")	
24.	165-803	1	SHIM (.0002")	
25.	165-804	1	SHIM (.003")	
26.	165-805	1	SHIM (.007")	
27.	174-026	1	INNER GEAR	
28.	178-438	1	BEARING RETAINER	
29.	157-501	1	INTERNAL SEAL	
30.	166-444	1	INNER SHAFT	
31.	106-755	5	SCREW (M10-1.50 X 30MM, SOC)	
32.	159-003	1	AIR VENT (02N)	
33.	514-123	1	PICKUP TUBE (02N-02NF90-2")	
34.	115-211	2	PLUG (08N, SQ, MAG)	
35.	149-927	1	SEAL (BLOCK V) LIP CD (D)	
36.	106-805	14	SCREW (M10-1.50 X 120MM, SOC)	
37.	166-271	1	INNER PINION	
38.	126-099	3	TAPERED RACE (3.25")	
39.	126-100	3	TAPERED BEARING (2")	
40.	115-457	1	EXTERNAL SNAP RING (2.500")	

FOOTNOTES:

NOTE:

**ROTATION GEARBOX**  
**JT2720 MACH 1 ALL TERRAIN ONLY**  
**BEGINS WITH S/N: 2X0001**

REF NO.	PART NUMBER	QTY	DESCRIPTION	REMARKS
41.	153-615	1	INTERNAL SEAL (5.750" ID)	
42.	107-485	1	SHIM	
43.	107-486	1	SHIM	
44.	107-487	1	SHIM	
45.	125-543	1	TAPERED RACE (7.75)	
46.	125-542	1	TAPERED BEARING	
47.	165-800	1	SHIM (.002")	
48.	165-801	1	SHIM (.003")	
49.	165-802	1	SHIM (.007")	
50.	107-575	1	SHIM	
51.	107-579	1	SHIM	
52.	153-153	1	SEAL	
53.	166-452	1	OUTPUT SHAFT	
54.	106-396	14	WASHER (M10, HARDENED)	
55.	307-904	1	MOTOR COVER	
56.	125-249	1	BEARING RACE	
57.	125-248	1	BEARING	
58.	107-803	1	PIN .125 X .25	
59.	160-1146	1	HARDENED SPACER	
60.	107-706	1	NUT, SPANNER	
	190-1386	1	GEARBOX NUT	
	255-1006	-	MOLLY PASTE (SINGLE APPLICATION)	

FOOTNOTES:

NOTE:

# CLAMP ASSEMBLY

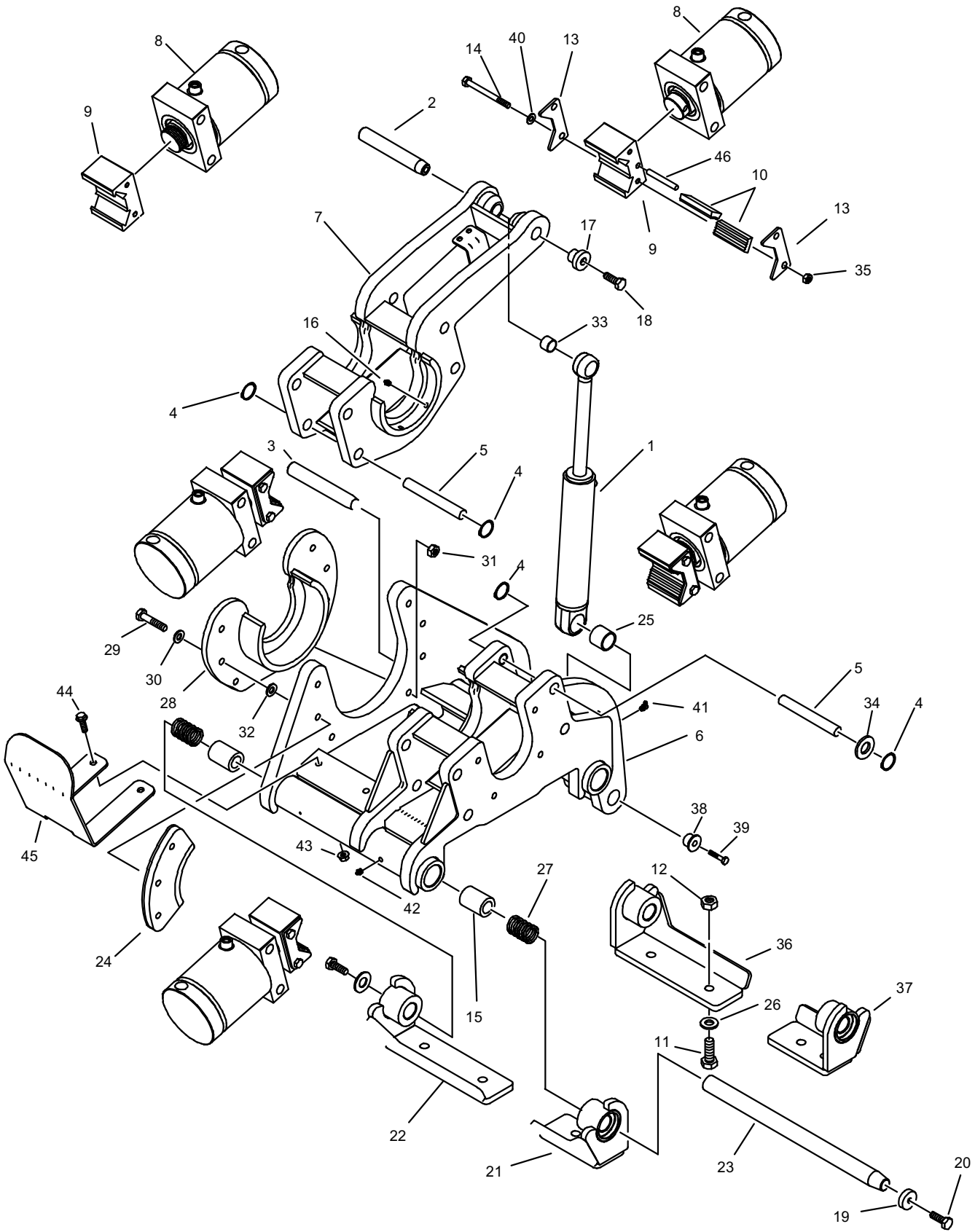



## CLAMP ASSEMBLY

REF NO.	PART NUMBER	QTY	DESCRIPTION	REMARKS
1.	151-031	1	CYL (2" X 1" X 8")	
2.	184-789	1	TAPERED PIN (25.4MM X 158.7MM)	
3.	178-075	1	TAPERED PIN (31.7MM X 240MM)	
4.	118-053	16	EXTERNAL SNAP RING (.875")	
5.	105-1133	8	PIN	
6.	303-360	1	STATIONARY CLAMP	
7.	303-624	1	ROTATION CLAMP	
8.	151-206	4	CYL (4.50" X 2.25" X 2.75")	BEFORE S/N:CMWA27T2E6000020
	151-212	4	CYL (4.50" X 2.25" X 2.75")	AFTER S/N: CMWA27T2A6000021
9.	303-817	4	JAW BLOCK	LOCTITE 242. BEFORE S/N:CMWA27T2E6000020
	329-179	4	JAW BLOCK	AFTER S/N: CMWA27T2A6000021
10.	350-446	8	GRIPPER INSERT	
11.	106-616	8	SCREW (M16-2 X 55MM, CL10.9)	
12.	106-545	8	LOCKNUT (M16-2.0,PRV TRQ,10.9)	
13.	308-643	8	RETAINER FORGING	
14.	105-022	8	BOLT (3/8-NC X 4")	LOCTITE 242
15.	178-456	4	BUSHING 1.25ID X 1.75OD X 1.75	LOCTITE 609
16.	115-003	8	ZERK (1/4-NF, STR)	
17.	181-981	1	TAPERED INSERT (1")	
18.	105-245	1	SCREW (M10-1.50 X 25MM)	
19.	106-006	4	WASHER (.531", HARDENED)	
20.	107-507	4	SCREW (M12-1.75X65MM) FULL THD	LOCTITE 242
21.	308-795	1	WRENCH MOUNT BRACKET, FRONT RH	
22.	308-796	1	WRENCH MOUNT BRACKET, REAR RH	
23.	178-489	2	PIN	
24.	306-783	2	BACKUP PLATE	
25.	125-771	1	COMPOSITION BUSHING (1.25")	
26.	106-398	8	WASHER (M16, HARDENED)	
27.	117-297	4	COMPRESSION SPRING	
28.	303-622	1	RETAINER	
29.	106-659	7	SCREW (M12-1.75 X 55MM)	
30.	106-397	7	WASHER (M12, HARDENED)	
31.	106-685	1	LOCKNUT(M12-1.75,PRV TRQ,10.9)	
32.	110-096	7	MACHINERY BUSHING (1/2")	

NOT SHOWN:

117-437 AR SHIM PLATE, FRONT MOUNT  
117-436 AR SHIM PLATE, REAR MOUNT

FOOTNOTES:

NOTE:

## CLAMP ASSEMBLY

REF NO.	PART NUMBER	QTY	DESCRIPTION	REMARKS
33.	125-770	1	COMPOSITION BUSHING (1")	
34.	105-318	AR	WASHER (7/8")	
35.	105-053	8	NUT (3/8-NC)	LOCTITE 242
36.	308-731	1	WRENCH MOUNT BRACKET, REAR	
37.	308-732	1	WRENCH MOUNT BRACKET, FRONT	
38.	181-982	1	TAPERED INSERT (1.25")	
39.	106-469	1	FLG SCREW (M12-1.75 X 30MM)	
40.	105-118	8	WASHER (3/8")	
41.	115-017	1	ZERK (02N65)	
42.	115-001	1	ZERK (02N)	
43.	106-387	2	FLG LOCKNUT (M10-1.50)	
44.	106-383	2	FLG LK SCREW (M10-1.50 X 30MM)	
45.	310-114	1	PLATE	
46.	107-777	4	SPIRAL SPRING PIN (.375" X 3.00")	

NOT SHOWN:

FOOTNOTES:

NOTE:



## WRENCH PIPE GUIDE

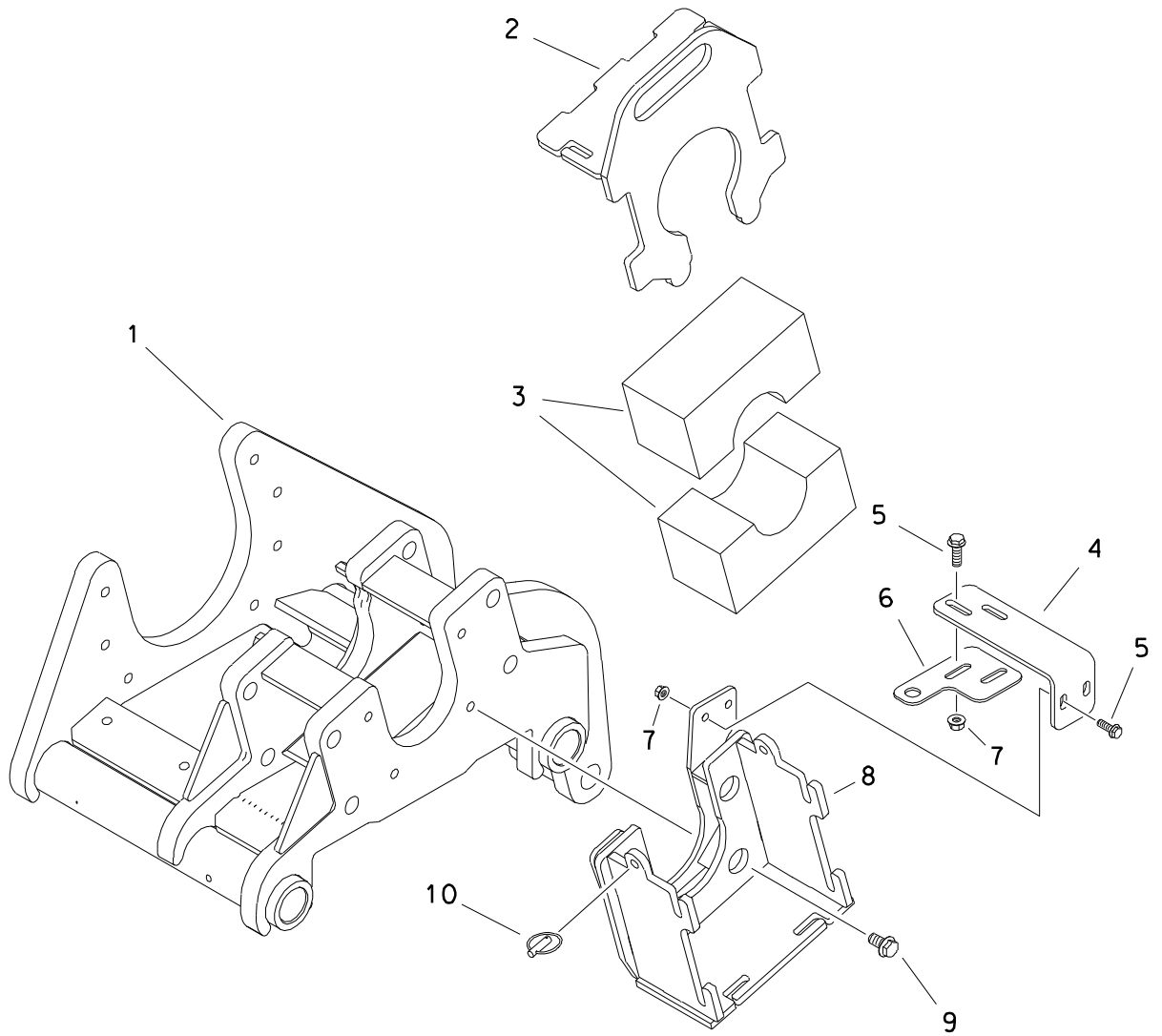



# TOOL BOX GAUGES

JT27T2 - AT27T2

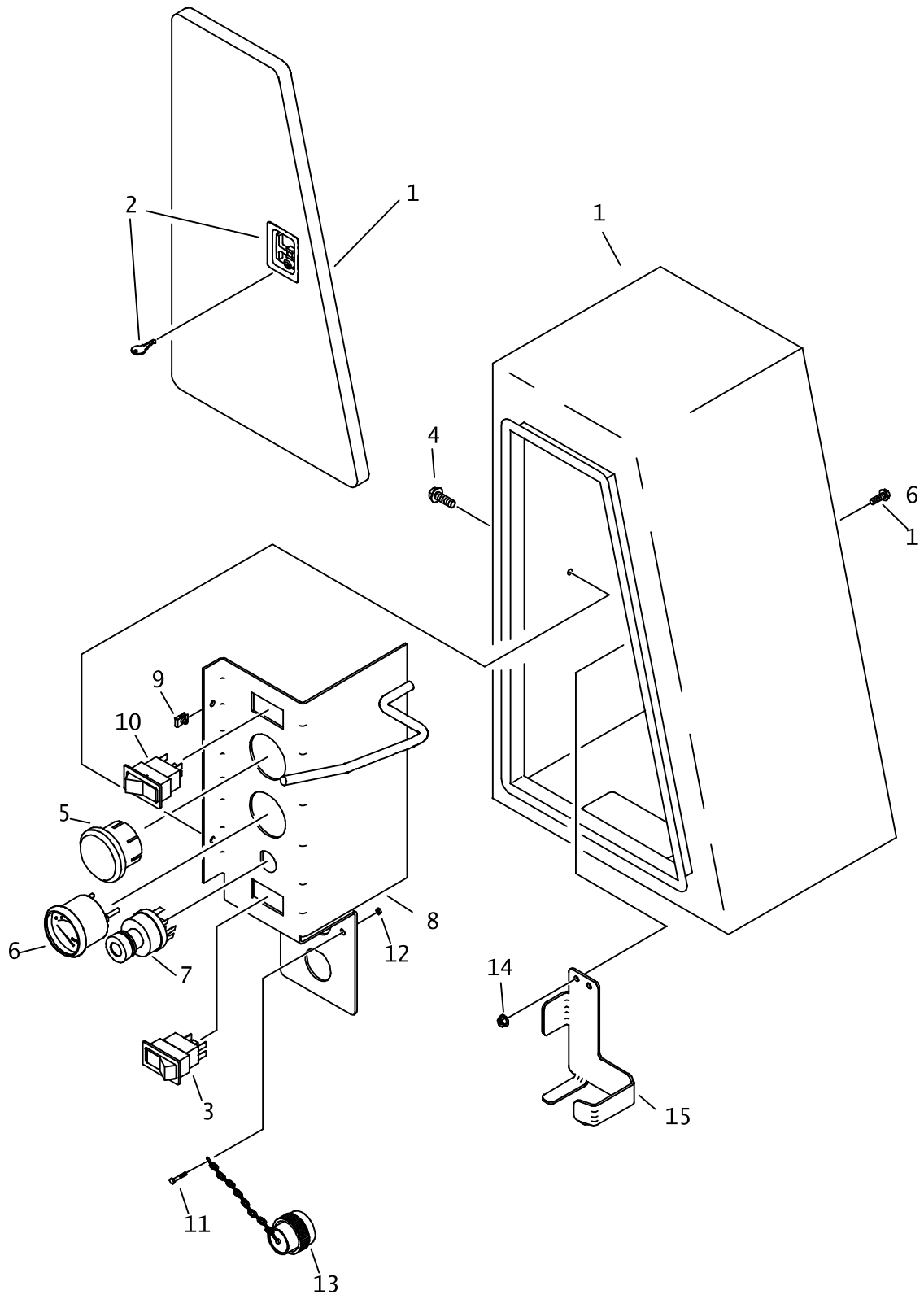

## TOOL BOX GAUGES

### JT27T2 - AT27T2

REF NO.	PART NUMBER	QTY	DESCRIPTION	REMARKS
1.	307-830	1	TOOL BOX	
2.	110-514	1	LOCKING LATCH, ADJUSTABLE	INCL KEYS
	110-596		KEYS (PAIR)	
3.	217-917	1	ROCKER SWITCH (DPDT) OFF-ON	NYOGEL 700016
4.	106-640	2	SCREW (M6-1.00 X 20MM, BUT SOC)	
5.	111-067	1	EXPANSION PLUG (2.125")	
6.	215-129	1	VOLT METER	
	215-415		NITE-LIGHT KIT (12V DC)	OPTION
7.	214-852	1	IGNITION SWITCH	
	214-961		KEY, PAIR (BASE CODE)	
	214-962		SWITCH MOUNTING NUT	
	217-769	2	KEY (PAIR)	
8.	306-998	1	GAUGE PANEL WELDMENT	
9.	106-574	2	CLIP NUT (M6-1.00)	
10.	217-907	1	ROCKER SWITCH (DPDT) ON-ON	NYOGEL 700016
11.	107-269	1	SCREW (#4-40 X 3/4", PAN)	
12.	106-277	1	NUT (#4-40, BRASS)	
13.	214-812	1	PROTECTIVE CAP	
14.	106-385	2	FLG LOCKNUT (M6-1.00)	
15.	313-986	1	CONTROL BOX BRACKET	
16.	106-378	2	FLG LK SCREW (M6-1.00 X 12MM)	

NOT SHOWN:

FOOTNOTES:

NOTE:

## REAR STABILIZERS

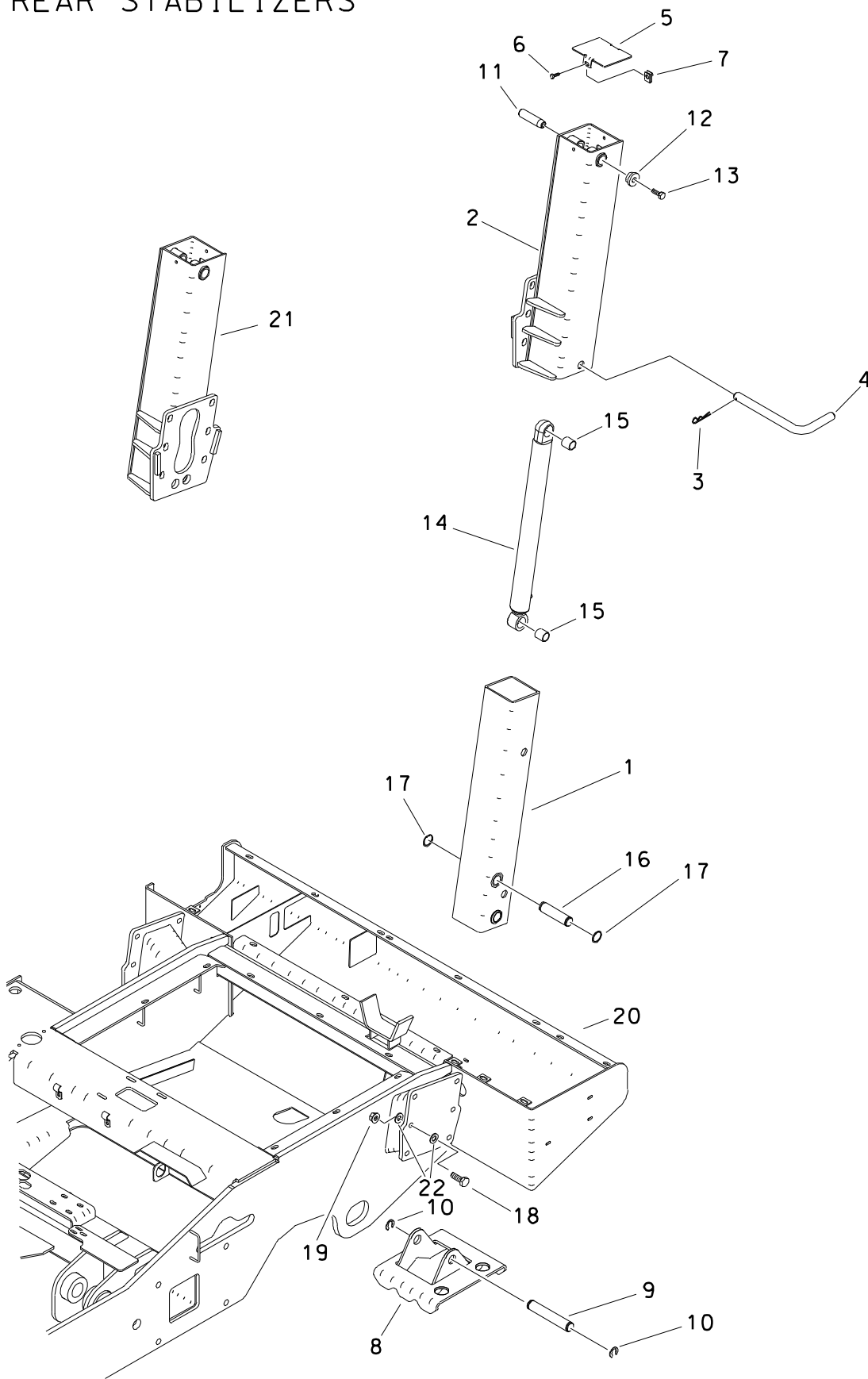



# REAR STABILIZERS

REF NO.	PART NUMBER	QTY	DESCRIPTION	REMARKS
1.	343-561	2	STABILIZER TUBE	
2.	309-642	1	TUBE ASS'Y (LEFT)	
3.	110-128	2	SPRING CLIP PIN (5/32" X 1")	
4.	343-540	2	PIN	
5.	309-974	2	COVER	
6.	106-162	4	SCREW (M8-1.25 X 20MM)	
7.	106-551	4	CLIP NUT (M8-1.25)	
8.	343-562	2	STABILIZER FOOT	
9.	343-919	2	PIN, STABILIZER FOOT	
10.	115-483	4	KLIP RING (1.25")	
11.	179-042	2	TAPERED PIN (31.7MM x 144MM)	
12.	181-982	2	TAPERED INSERT (1.25")	
13.	106-469	2	FLG SCREW (M12-1.75 X 30MM)	
14.	151-065	2	CYL (2.0 X 1.25 X 20.0)	
15.	125-771	4	COMPOSITION BUSHING (1.25")	
16.	343-918	2	PIN, LOWER	
17.	118-007	4	INTERNAL SNAP RING (1.25")	
18.	106-340	12	SCREW (M16-2.00 X 50MM)	
19.	106-545	12	LOCKNUT (M16-2.0, PRV TRQ, 10.9)	
20.	305-710	-	MAIN FRAME	
21.	309-672	1	TUBE ASS'Y (RIGHT)	
22.	106-398	24	WASHER (M16, HARDENED)	

FOOTNOTES

## TRACK GROUP

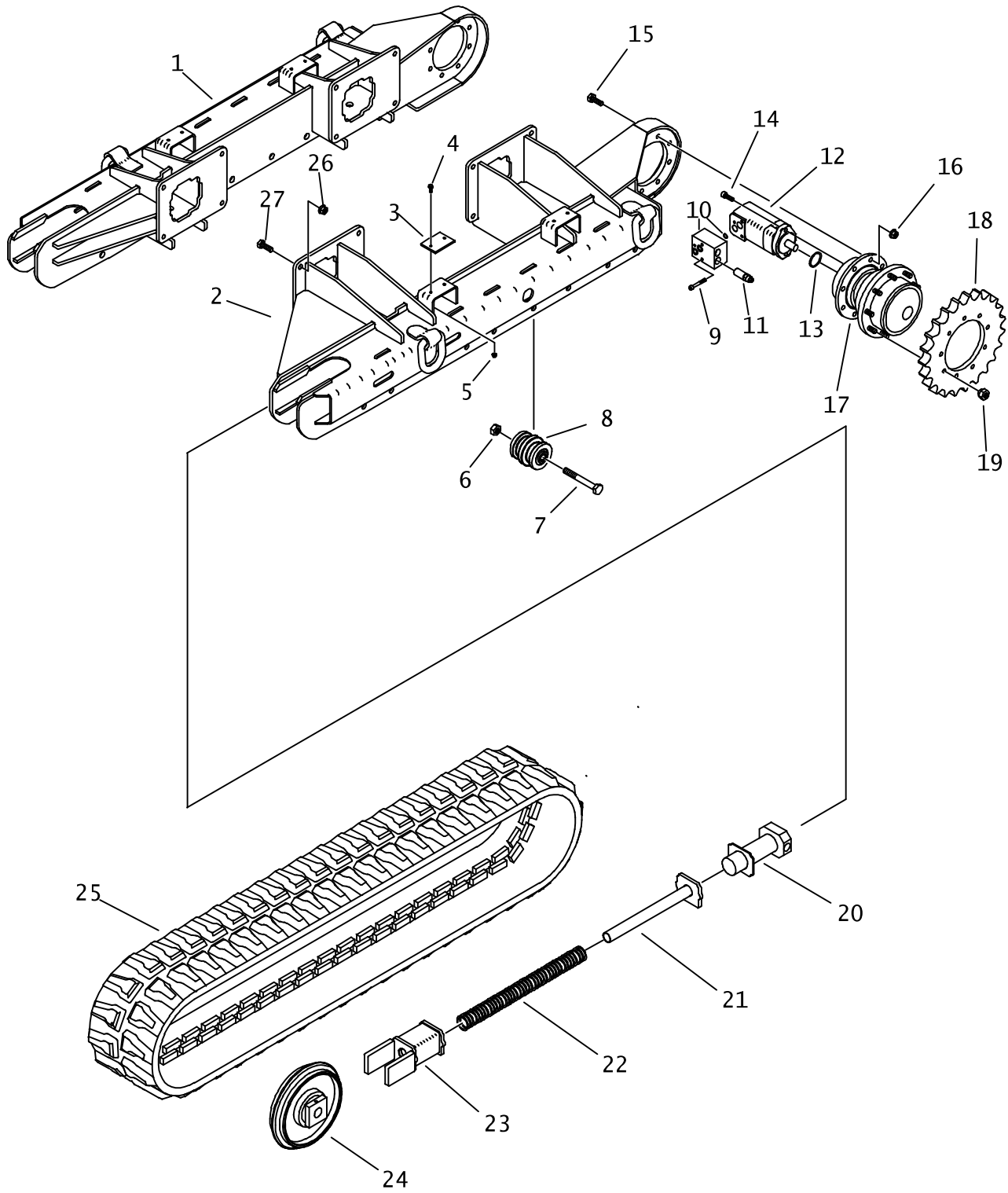

## TRACK GROUP

REF NO.	PART NUMBER	QTY	DESCRIPTION	REMARKS
1.	308-307	1	R.H. TRACK FRAME	
2.	308-306	1	L.H. TRACK FRAME	
3.	356-788	4	SLIDE PAD	
4.	106-381	8	FLG LK SCREW (M8-1.25 X 25mm)	
5.	106-386	8	FLG LOCKNUT (M8-1.25)	
6.	106-665	18	LOCKNUT (M20-2.50, 10.9)	
7.	106-727	18	SCREW (M20-2.50 X 180mm, 10.9)	
8.	170-338	18	IDLER ROLLER PARTS	END AT UNITS W/S/N 2W0033; END JT UNITS W/S/N 2V2871
	129-010	18	IDLER ROLLER PARTS	BEGIN AT UNITS W/S/N 2W0034; BEGIN JT UNITS W/S/N 2W0136
9.	105-857	6	BOLT (3/8-NC X 3", SOC, GD8)	
10.	153-143	-	COUNTERBALANCE MANIFOLD	INCL O-RINGS
	155-776	-	O-RING (117 D70)	
11.	158-018	4	RELIEF CARTRIDGE	
	500-373		SEAL REPAIR KIT	
12.	158-953	2	HYD MOTOR	
	500-658		SEAL REPAIR KIT	
13.	157-099	2	O-RING (042 D70)	
14.	105-282	4	BOLT (1/2-NC X 1-1/4", SOC)	INSTALL WITH 277 LOCTITE; TORQUE TO 130 FT LBS
15.	106-074	16	SCREW (M16-2.00 X 60mm)	
16.	106-355	16	FLG NUT (M16-2.00, 10.9)	
17.	<del>166-140</del>	2	PLANETARY GEARBOX (TRACK)	ENDS WITH S/N 2V2019
	166-414	2	PLANETARY GEARBOX	BEGINS WITH S/N 2V2020
18.	141-586	2	23 TOOTH TRACK SPROCKET	
19.	105-114	18	LUG NUT (1/2-NF)	INSTALL WITH 242 LOCTITE; TORQUE TO 100 FT LBS
20.	151-181	2	GREASE CYLINDER	
21.	343-550	2	TUBE	
22.	117-112	2	SPRING	
23.	343-551	2	YOKE	
24.	170-339	2	FRONT IDLER ROLLER	
25.	308-746	2	RUBBER TRACK 320MM, 98P, 52.5MM)	
26.	106-545	16	LOCKNUT (M16-2.0, PRV TRQ, 10.9)	
27.	106-340	16	SCREW (M16-2.00 X 50MM)	

FOOTNOTES

NOTE:

G

807-540

# PLANETARY GEAR BOX-TRACK DRIVE

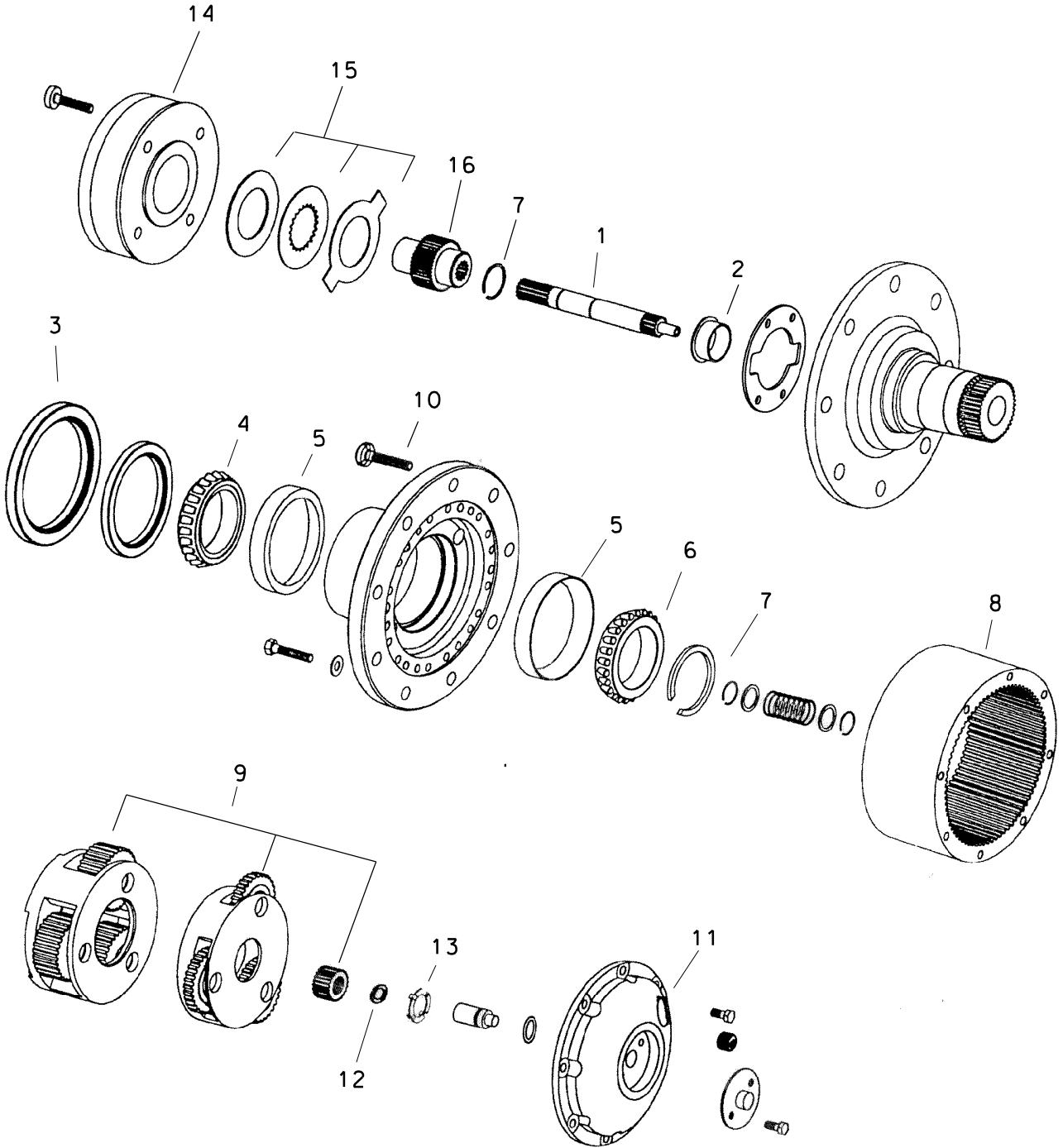

# PLANETARY GEAR BOX-TRACK DRIVE

REF NO.	PART NUMBER	QTY	DESCRIPTION	REMARKS
	166-140		PLANETARY GEARBOX (TRACK)	
	166-414		PLANETARY GEARBOX	
1.	501-838	1	INPUT SHAFT (6")	
2.	126-074	1	FLANGE BEARING (1.75")	
3.	157-521	1	EXTERNAL SEAL (3.375")	
4.	125-387	1	TAPERED BEARING (2.625")	
5.	125-368	2	TAPERED RACE (4.330")	
6.	125-388	1	TAPERED BEARING (2.687")	
7.	501-629	2	EXTERNAL SNAP RING KIT (2.63")	
8.	501-839	1	RING GEAR (6")	
9.	499-409	1	PLANET-SUN GEAR SET	
10.	105-232	9	LUG BOLT (1/2 - NF X 2-3/8")	
11.	501-855	1	COVER (6")	
12.	501-842	1	THRUST WASHER (1.5")	
13.	501-630	1	THRUST WASHER	
14.	501-859	1	BRAKE, HYDRA (6")	EARLY UNITS
	499-405	1	HYDRAULIC BRAKE	LATE UNITS
15.	501-738	-	BRAKE DISK/SPACER BAR	EARLY UNITS
	499-404	-	STACK SERVICE KIT	LATE UNITS
16.	501-836	1	ADAPTER, SPLINED	

FOOTNOTES

# GROUND DRIVE BRAKE

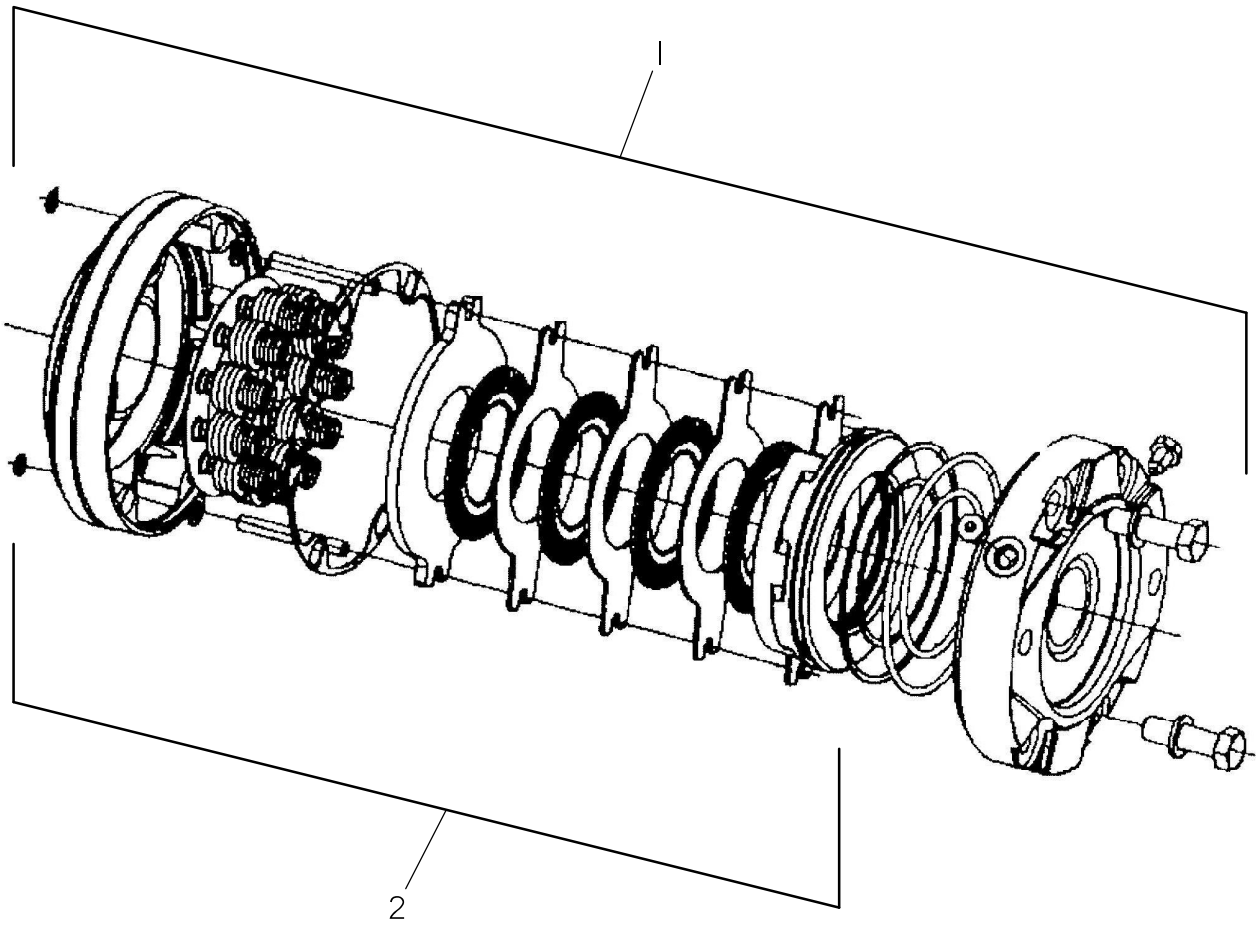

## GROUND DRIVE BRAKE

REF NO.	PART NUMBER	QTY	DESCRIPTION	REMARKS
1.	499-405		HYDRAULIC BRAKE	
2.	499-404		STACK SERVICE KIT	SEE FOOTNOTE I

NOT SHOWN:

FOOTNOTES:

KIT INCLUDES: TORQUE PIN O-RING, TORQUE PIN PUSH RETAINER, 2X SPRING, TORQUE PIN, PRIMARY DISC, ROTATING DISC & STATIONARY DISC.

NOTE:

## IDLER

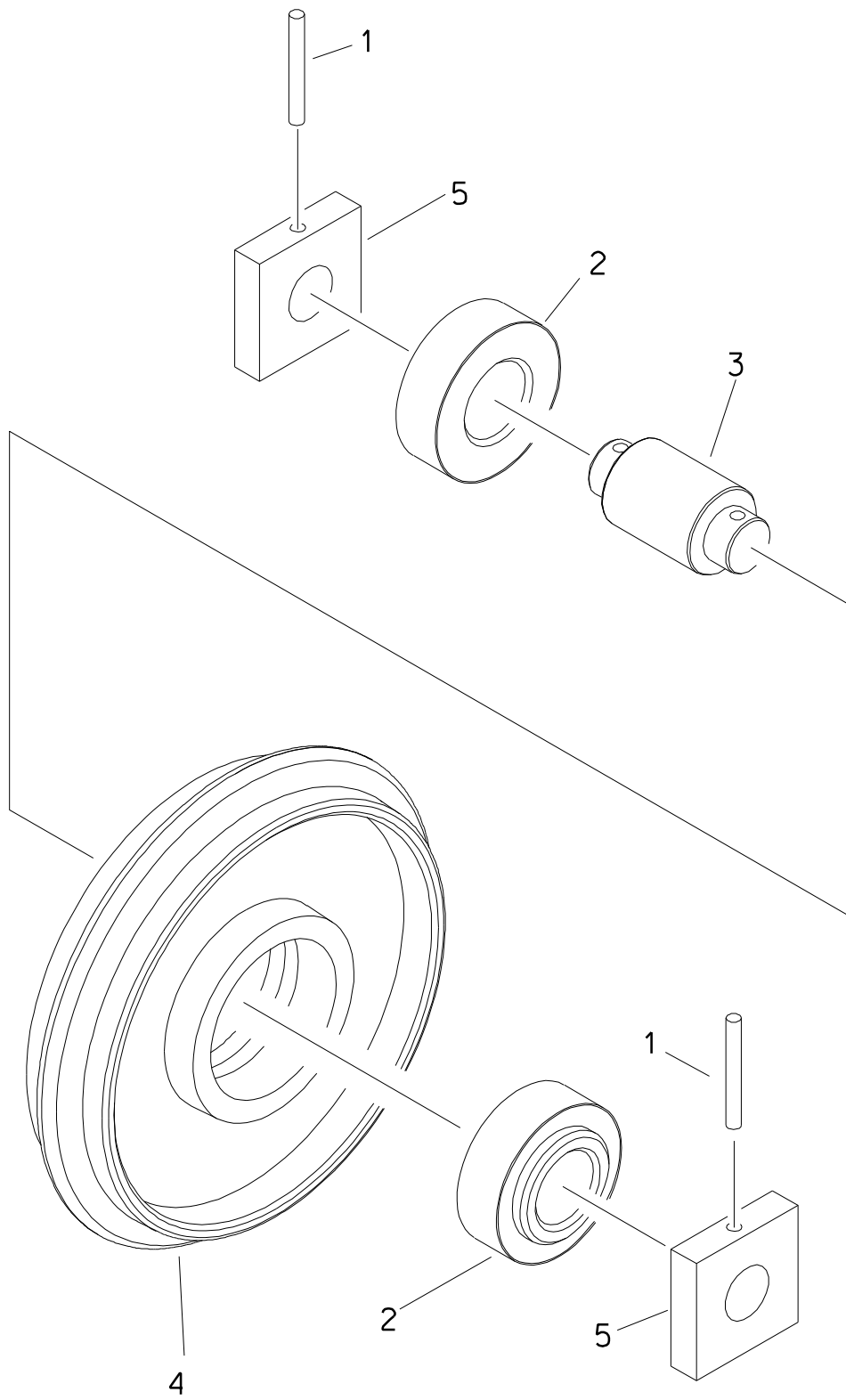



# IDLER

REF NO.	PART NUMBER	QTY	DESCRIPTION	REMARKS
	170-339		FRONT IDLER ROLLER	INCL REF NO'S 1 THRU 5
1.	105-561	2	ROLL PIN (3/8" X 2-3/4")	
2.	125-134	2	BALL BEARING (2.362")	
3.	343-836	1	IDLER SHAFT	
4.	343-837	1	IDLER	
5.	343-835	2	PUSH BLOCK	

FOOTNOTES

# IDLER ROLLER

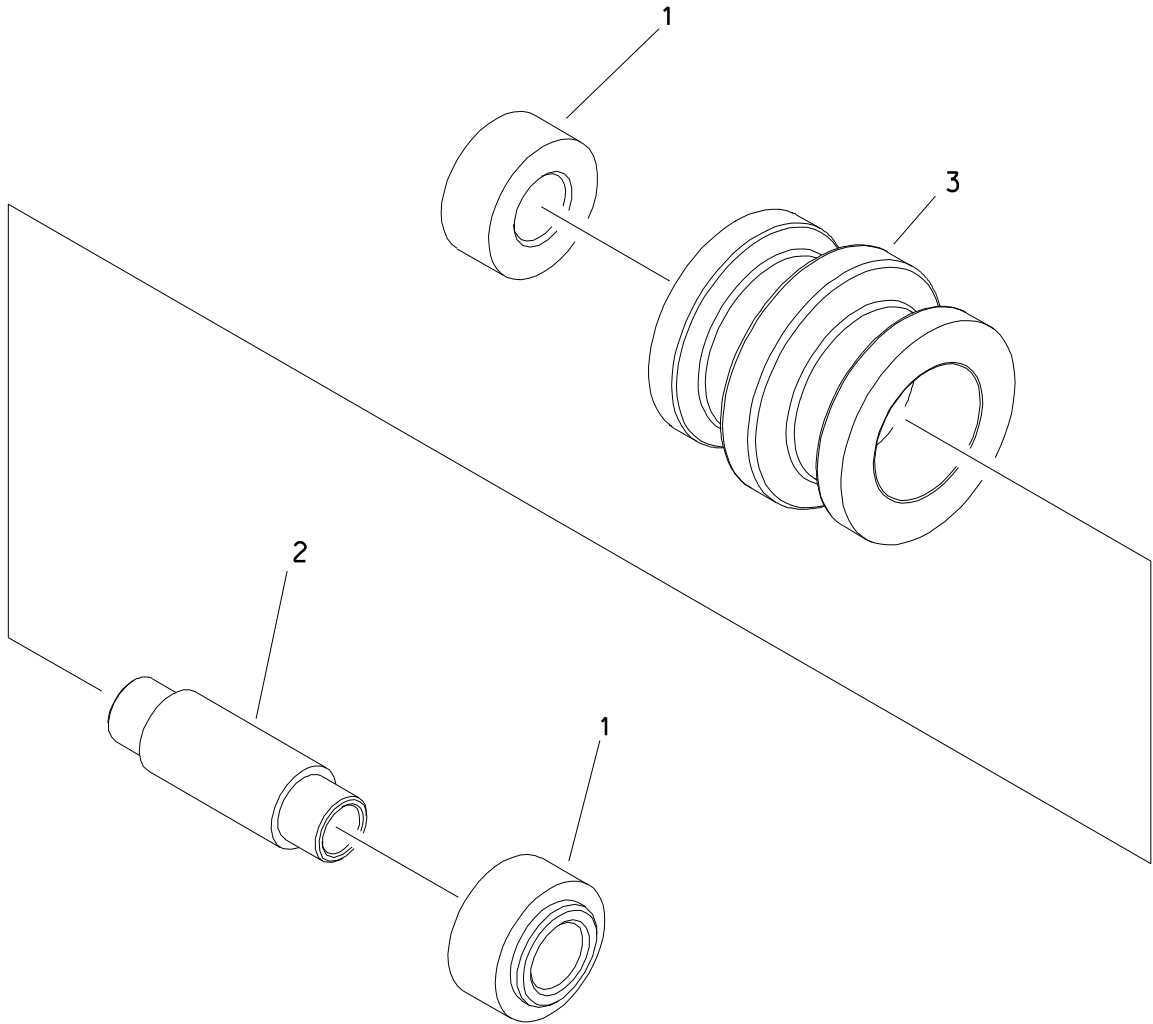

# IDLER ROLLER

REF NO.	PART NUMBER	QTY	DESCRIPTION	REMARKS
	170-338		IDLER ROLLER	INCL REF NO'S 1 THRU 3
1.	125-135	2	BALL BEARING (2.362")	
2.	343-825	1	ROLLER SHAFT	
3.	343-824	1	ROLLER SHELL	

FOOTNOTES

# GREASE CYLINDER

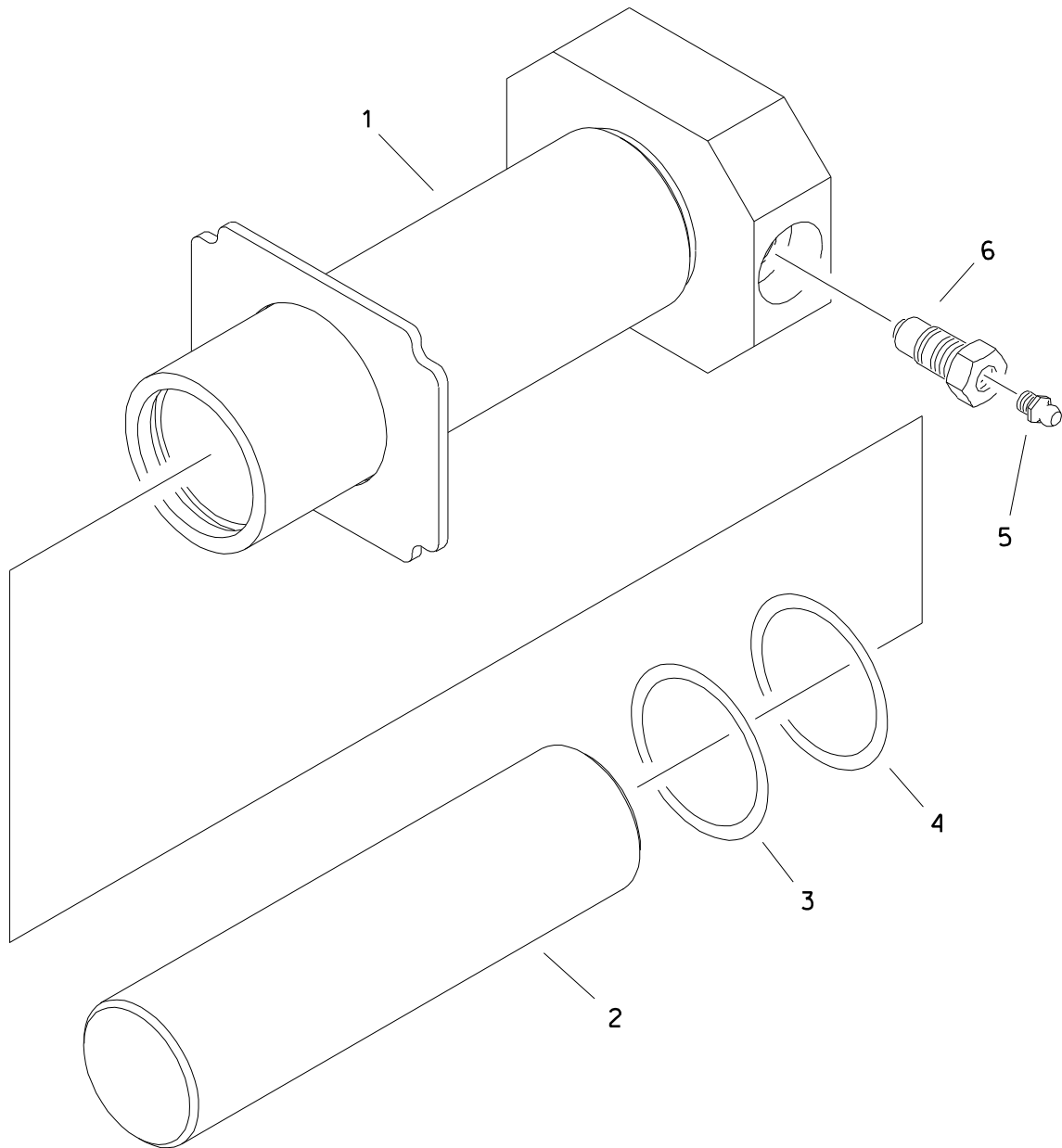

# GREASE CYLINDER

REF NO.	PART NUMBER	QTY	DESCRIPTION	REMARKS
	151-181		GREASE CYLINDER	INCL REF NO'S 1,2,3,4, & 6.
1.	343-552	1	GREASE CYLINDER	
2.	350-804	1	CYLINDER ROD	
3.	157-021	1	BACKUP RING (228 D90)	
4.	500-031	1	O-RING (228 D90)	
5.	115-019	1	ZERK (Q2N)	
6.	159-093	1	RELIEF VALVE (5/8 - NF, Q2N)	

FOOTNOTES

# HOODS

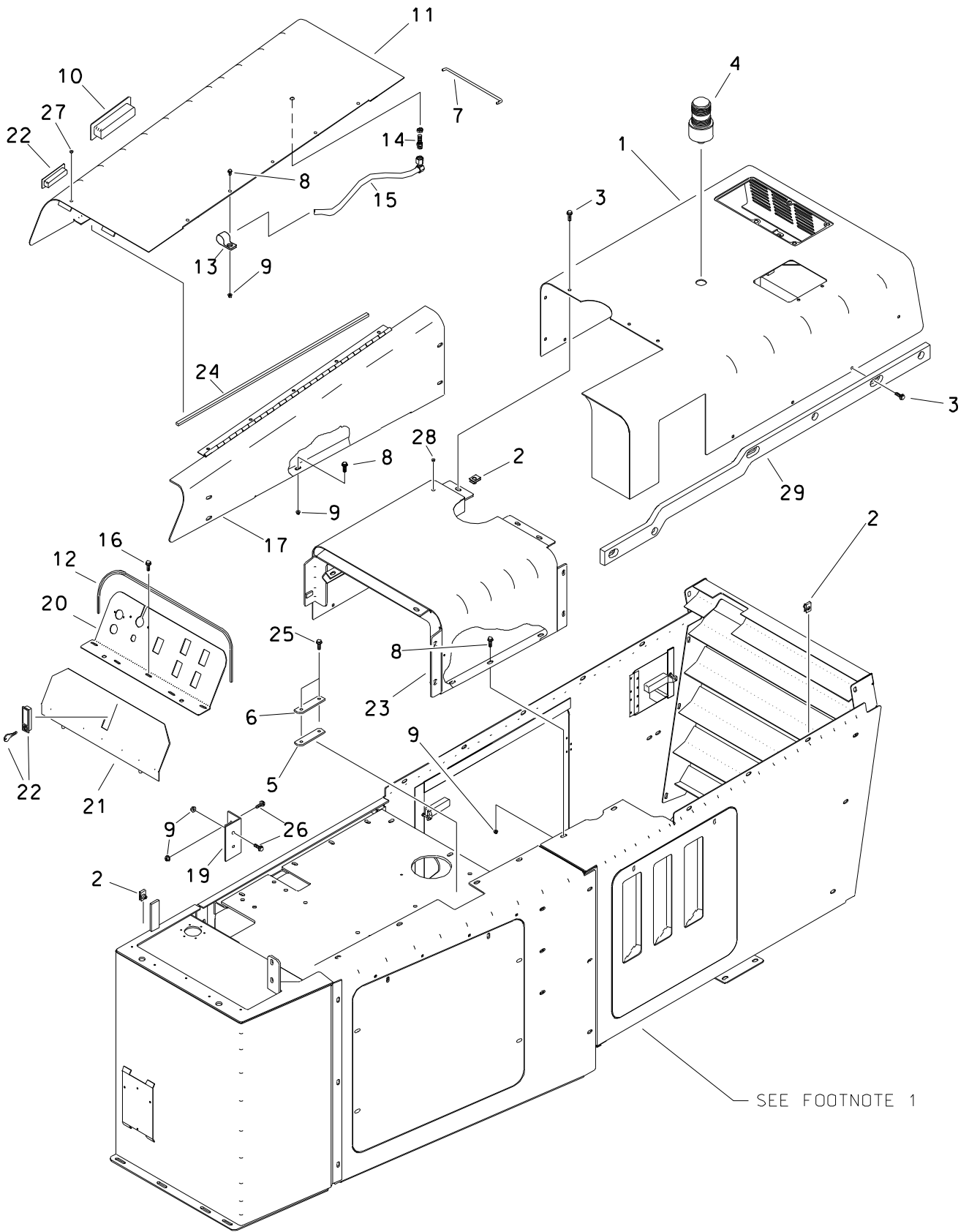

SEE FOOTNOTE 1

L

## HOODS

REF NO.	PART NUMBER	QTY	DESCRIPTION	REMARKS
1.	310-785	1	TOP COVER (REAR)	
2.	106-551	30	CLIP NUT (M8-1.25)	
3.	106-991	27	FLG LK SCREW (M8-1.25 X 20mm)	
4.	214-722	1	STROBE LIGHT (AMBER)	
	217-870	-	STROBE LIGHT BULB	
	217-296	1	STROBE LIGHT AMBER MED PROFILE	
	214-991	-	REPLACEMENT FLASH TUBE	
	217-302	-	REPLACEMENT LENS (AMBER)	
	217-301	-	BRUSH GUARD	
	157-645	2	WEATHER PAC-SEAL (2.80MM)	
	214-103	1	(2-WAY) MALE CONNECTOR	
	214-104	2	PACKARD MALE TERMINAL	
5.	307-550	1	BACK UP BAR	
6.	307-551	1	HOOD COVER PLATE	
7.	343-932	1	PROP ROD	
	105-512	1	COTTER PIN (3/32" X 3/4")	
	110-492	1	J-CLIP (.343")	
	106-862	1	POP RIVET (1/8" X .000")	
	105-284	1	WASHER (3/16")	
	106-205	1	WASHER (.191")	
8.	106-162	11	FLG SCREW (M8-1.25 X 20MM)	
9.	106-386	15	FLG LOCKNUT (M8-1.25)	
10.	110-989	2	POCKET PULL	
11.	344-122	1	PANEL/HOOD	
12.	116-421	AR	BULK EDGE (1/8", SOLD PER 1')	USE 1 @ 32"
13.	110-126	2	BOLT-ON CLAMP (1/2")	
14.	211-055	1	ANTENNA BULKHEAD CONNECTOR	
15.	211-072	1	CABLE	
16.	106-378	5	FLG LK SCREW (M6-1.00 X 12MM)	
17.	343-325	1	LEFT HOOD	
18.	106-381	17	FLG LK SCREW (M8-1.25 X 25mm)	
19.	305-848	1	HOOD ADJUSTMENT BRACKET	
20.	305-847	1	PANEL ENGINE CONSOLE	
21.	350-434	1	VANDAL GUARD	
22.	117-558	2	ADJUST LEVER LATCH (LOCKING)	BEGINS WITH S/N 2X0001
	214-961	-	KEY, PAIR (BASE CODE)	
	217-309	-	LOCK PLUG 4/LATCH (BASE CODE)	
	106-270	1	SCREW (M6-1.00 X 20MM)	ADJUSTMENT BOLT
	110-757	2	LEVER LATCH (ADJUST, LOCKING)	INCL KEYS
	110-596	-	KEYS (PAIR)	
23.	310-387	1	BRIDGE	USE 1 @ 32"
24.	116-489	AR	BULK EDGE (1/8", SOLD PER 1 FT)	
25.	106-049	2	BOLT (#10-24 X 3/4", PLPS)	
26.	106-992	4	FLG LK SCREW (M8-1.25 X 25MM)	
27.	153-366	2	BUTTON PLUG (BPF - 1/4)	
28.	111-110	4	PLUG (3/8)	
29.	309-933	1	WEAR STRIP	
FOOTNOTES				
1.	SEE PAGE TITLED "SIDE PANELS" FOR PANELS.			

# SIDE PANELS

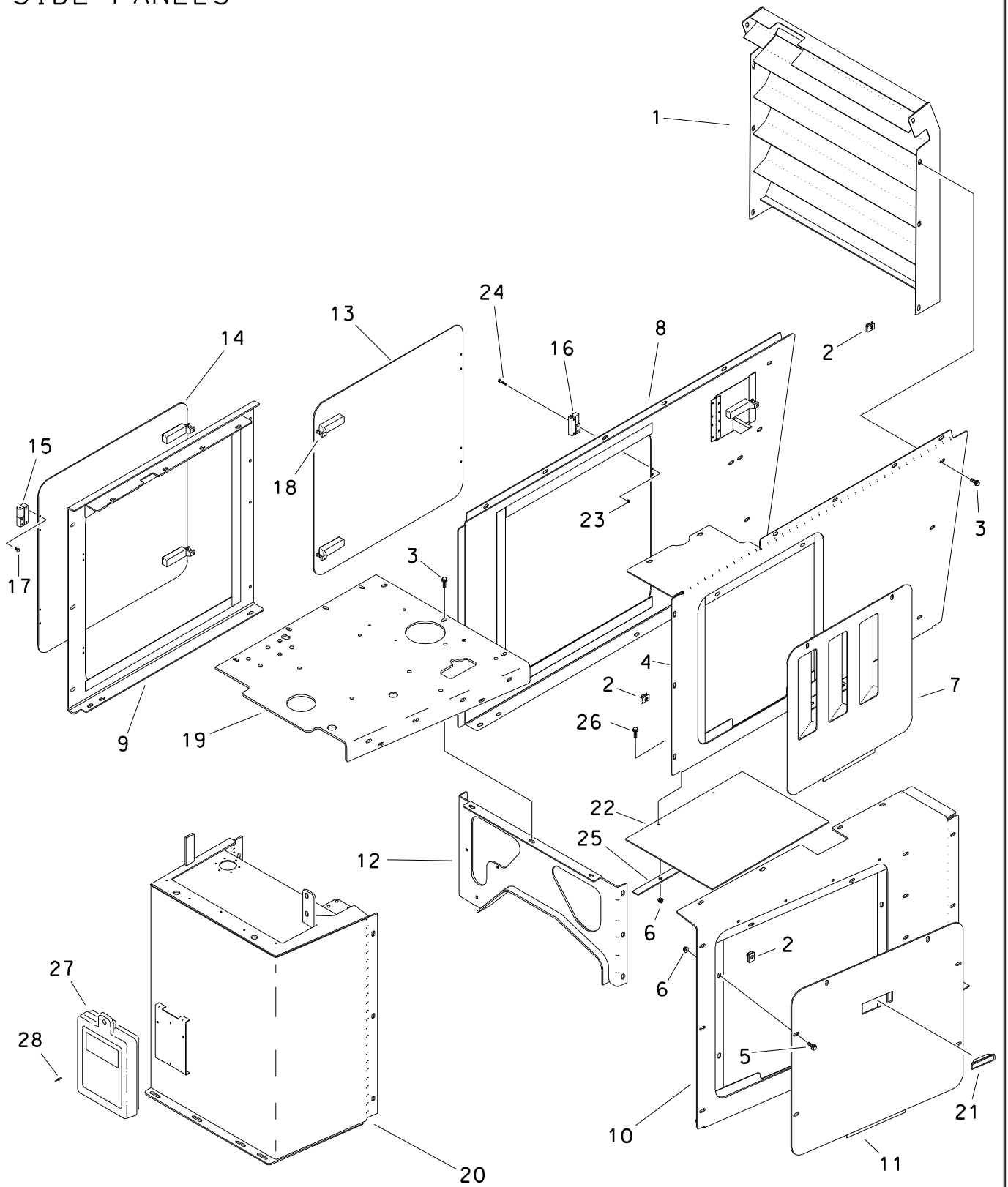



## SIDE PANELS

REF NO.	PART NUMBER	QTY	DESCRIPTION	REMARKS
1.	309-882	1	BACK GRILLE	
2.	106-551	42	CLIP NUT (M8-1.25)	
3.	106-381	21	FLG LK SCREW (M8-1.25 X 25MM)	
4.	310-388	1	REAR LOWER PANEL, LH	
5.	106-991	42	FLG LOCK SCREW (M8-1.25 X 20mm)	
6.	106-386	24	FLG LOCKNUT (M8-1.25)	
7.	308-571	1	VENT	
8.	310-461	1	REAR, RH, LWR	
9.	343-189	1	FRONT PANEL (RH)	
10.	308-394	1	FRONT PANEL, LH	
11.	309-092	1	FRONT LEFT DOOR	
12.	343-775	1	SHEET METAL SUPPORT	
13.	310-451	1	RIGHT REAR DOOR	
14.	343-514	1	RIGHT DOOR	
15.	107-550	2	LIFT-OFF HINGE (OFFSET) LH	
16.	107-549	2	LIFT-OFF HINGE (OFFSET) RH	
17.	106-428	8	SCREW (M5-0.80 X 14mm, SOC)	LOCTITE 242
18.	117-558	5	ADJUST LEVER LATCH (LOCKING)	BEGINS WITH S/N 2X0001
	214-961		KEY, PAIR (BASE CODE)	
	217-309		LOCK PLUG 4/LATCH (BASE CODE)	
	<del>110-757</del>	5	LEVER LATCH (ADJUST, LOCKING)	INCL KEYS
	110-596		KEYS (PAIR)	
19.	305-677	1	PLATE, BATTERY SUPPORT	
20.	149-468	-	HYDRAULIC TANK	
21.	117-427	1	POCKET PULL HANDLE	
22.	117-307	1	FLAP	
23.	106-850	8	LOCKNUT (M5-0.80)	
24.	106-426	8	SCREW (M5-0.80 X 25MM, SOC)	
25.	309-781	1	MUD FLAP RETAINER	
26.	106-162	2	FLG SCREW (M8-1.25 X 20MM)	
27.	250-622	1	MANUAL COMPARTMENT	
28.	110-560	4	POP RIVET (3/16" X 1/2", ALUM)	

## FOOTNOTES

# UPPER SOUND INSULATION

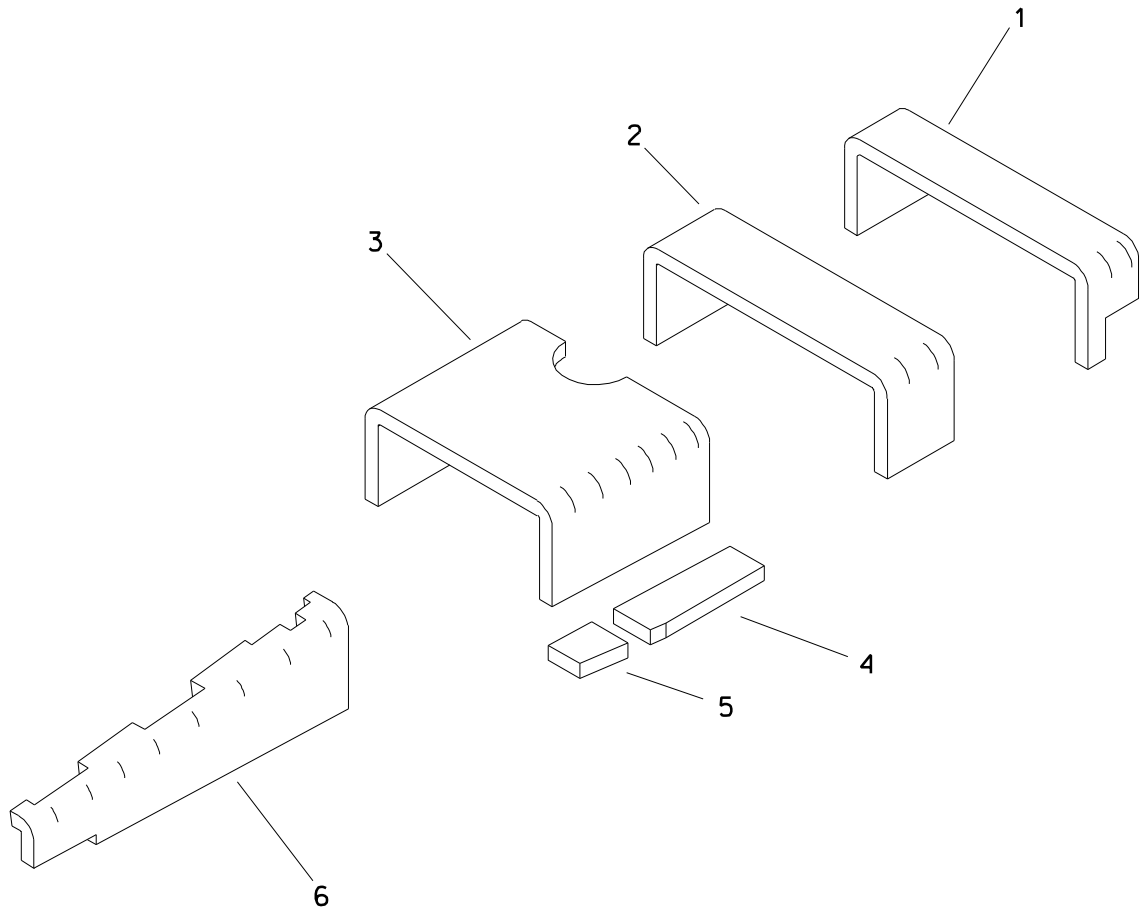

# UPPER SOUND INSULATION

REF NO.	PART NUMBER	QTY	DESCRIPTION	REMARKS
1.	343-950	-	NOISE BARRIER	REAR TOP PANEL
2.	117-318	-	NOISE BARRIER	REAR TOP PANEL
3.	343-951	1	NOISE BARRIER	CENTER TOP PANEL
4.	343-952	1	NOISE BARRIER	CENTER TOP PANEL, LOWER
5.	117-229	1	NOISE BARRIER	BOTTOM PANEL
6.	343-954	1	NOISE BARRIER	FRONT TOP PANEL

FOOTNOTES

# LOWER SOUND INSULATION

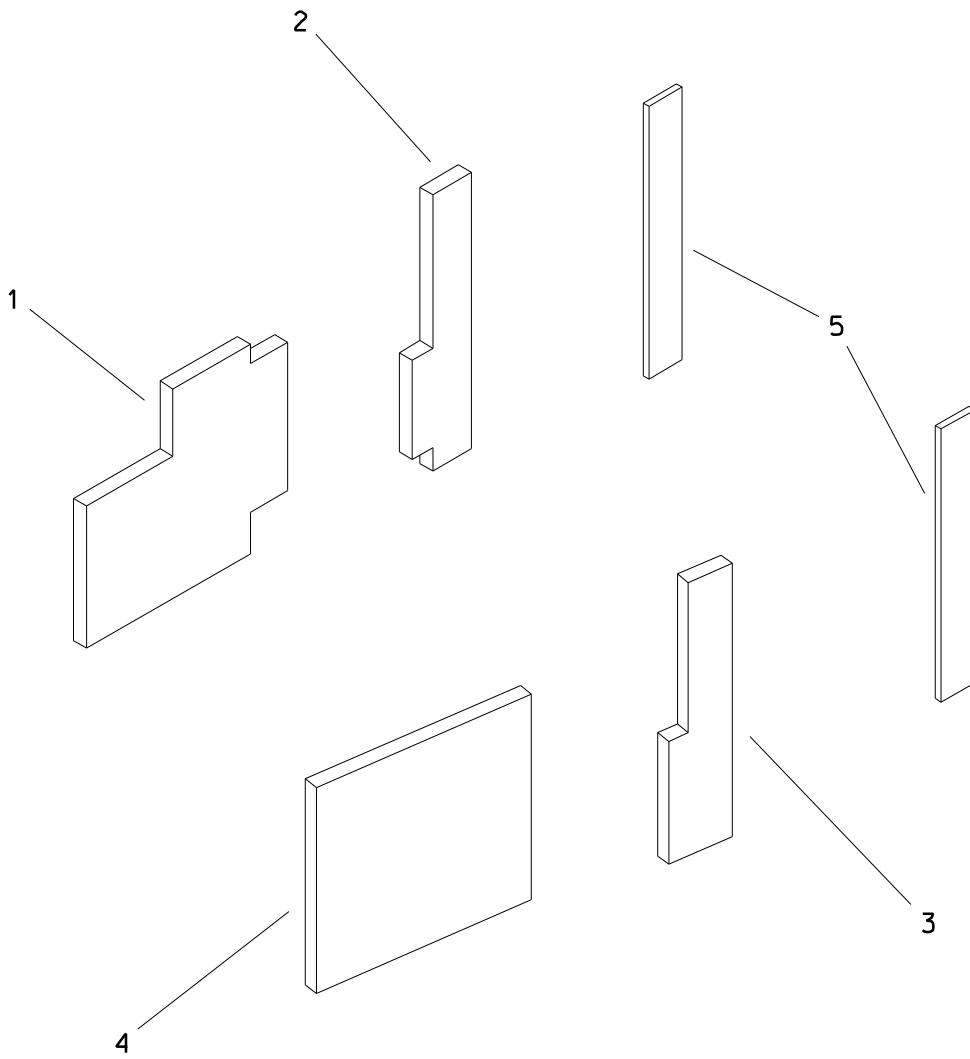

# LOWER SOUND INSULATION

REF NO.	PART NUMBER	QTY	DESCRIPTION	REMARKS
1.	343-945	1	NOISE BARRIER	RIGHT FRONT DOOR
2.	343-946	1	NOISE BARRIER	RIGHT SIDE PANEL
3.	343-949	1	NOISE BARRIER	LEFT SIDE PANEL
4.	343-948	1	NOISE BARRIER	LEFT FRONT DOOR
5.	116-979	2	NOISE BARRIER, RADIATOR	RIGHT AND LEFT SIDE OF RADIATOR

FOOTNOTES

# COVERS

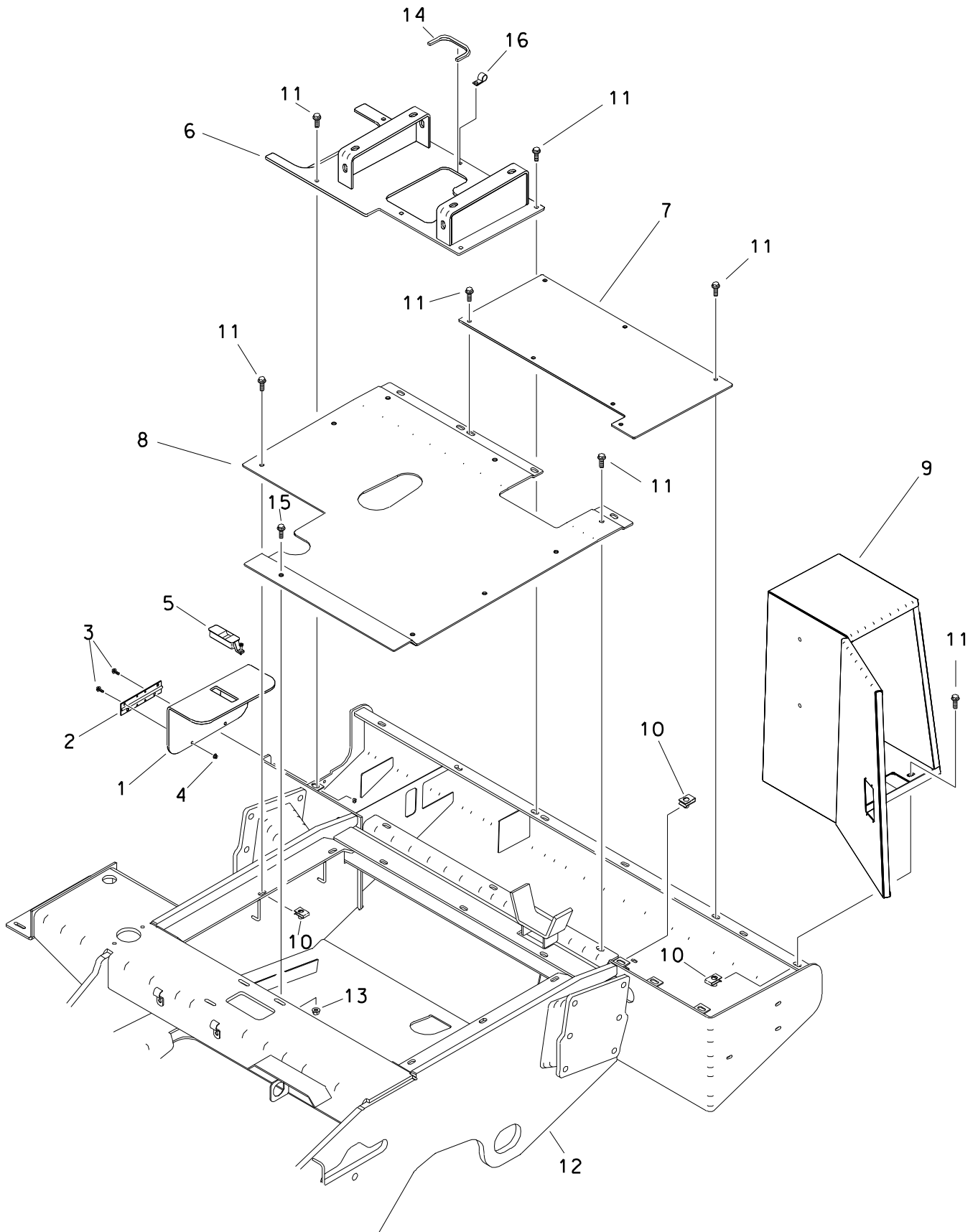

# COVERS

REF NO.	PART NUMBER	QTY	DESCRIPTION	REMARKS
1.	343-262	1	RIGHT REAR DOOR	
2.	303-336	1	HINGE	
3.	106-379	4	FLG LK SCREW (M6-1.00 X 20mm)	
4.	106-385	4	FLG LOCKNUT (M6-1.00)	
5.	117-558	1	ADJUST LEVER LATCH (LOCKING)	BEGINS WITH S/N 2X0001
	214-961		KEY, PAIR (BASE CODE)	
	217-309		LOCK PLUG 4/LATCH (BASE CODE)	
	110-757	1	LEVER LATCH (ADJUST, LOCKING)	INCL KEY
	110-596		KEYS (PAIR)	
6.	343-563	1	COVER	
7.	343-889	1	PLATE, TOP REAR	
8.	343-894	1	COVER, TOP	
9.	307-830	1	TOOL BOX	
10.	106-558	24	CLIP NUT (M10-1.50)	
11.	106-383	24	FLG LK SCREW (M10-1.50 X 30MM)	
12.	305-710	-	MAIN FRAME	
13.	106-387	1	FLG LOCKNUT (M10-1.50)	
14.	115-704	AR	BULK EDGE (1/4", SOLD PER 1")	USE 1 @ 9"
15.	106-724	1	FLG SCREW (M10-1.50 X 25MM)	
16.	110-333	1	BOLT-ON CLAMP (1")	

FOOTNOTES





## FUEL TANK

REF NO.	PART NUMBER	QTY	DESCRIPTION	REMARKS
1.	343-547	1	FUEL TANK	
2.	353-490	5	RUBBER BELT (15.3mm X 526mm)	
3.	353-420	1	FUEL SENDER	
	165-704	1	GASKET	
4.	105-185	5	BOLT (#10-24 X 1/2", RD SLT)	
5.	156-269	2	S/O COUPLER (04H-05H90)	SEE FOOTNOTE 1
6.	116-325	2	GRMMET (.362")	SEE FOOTNOTE 1
7.	118-096	AR	BULK FUEL TUBING (1/4", PER FT)	USE 1 @ 6"
8.	118-096	AR	BULK FURL TUBING (1/4", PER FT)	USE 1 @ 16"
9.	110-563	3	SPRING CLAMP (3/8")	
10.	156-268	1	FUEL STRAINER (04H)	
	194-505	1	FUEL PICKUP (04H)	BEGINS WITH S/N
11.	116-108	AR	BULK HOSE (5/16", SOLD PER 1")	USE 1 @ 84"
12.	116-108	AR	BULK HOSE (5/16", SOLD PER 1")	USE 1 @ 84"
13.	110-528	4	SNAP-ON CLAMP (.531" TO .593")	
14.	156-275	1	TUBE CONNECTOR (04H-05T)	INCL REF NOS 15 & 16
15.	156-276	1	FERRULE (05T)	
16.	156-277	1	COMPRESSION NUT (05T)	
17.	115-444	1	PLUG (04N, SOC, SS)	
18.	343-240	1	RETAINER, FUEL TANK	
19.	106-383	3	FLG LK SCREW (M10-1.5 X 30mm)	
20.	106-558	3	CLIP NUT (M10-1.50)	
21.	364-487	1	FUEL FILL BRACKET	
22.	106-162	2	FLG SCREW (M8-1.25 X 20mm)	
23.	106-386	2	FLG LOCKNUT (M8-1.25)	
24.	364-080	1	FILLER NECK	
	364-659	1	FILLER NECK	BEGINS WITH S/N
25.	110-010	1	FUEL CAP (1-1/2")	
26.	116-952	AR	FUEL HOSE (2" X 32")	
27.	110-134	3	WORM CLAMP (2.06" TO 2.75")	
28.	116-322	AR	BULK HOSE (1/2", SOLD PER 1")	USE 1 @ 27.50"
29.	110-217	2	WORM CLAMP (7/16" TO 1")	
30.	117-690	1	ABRASION SLEEVE (1.25" X 58")	
31.	110-560	4	POP RIVET (3/16" X 1/2", ALUM)	
32.	106-205	4	WASHER (.191")	
33.	364-663	1	FILLER NECK SCREEN	BEGINS WITH S/N
34.	155-708	1	O-RING (218 D70)	BEGINS WITH S/N

## FOOTNOTES

1. APPLY RED RTV SILICONE AROUND OUTSIDE CIRCUMFERENCE OF REF. 5 & 6 PRIOR TO INSTALLATION.

# COOLANT SYSTEM MOUNTING

BEGINS WITH S/N 2X0001

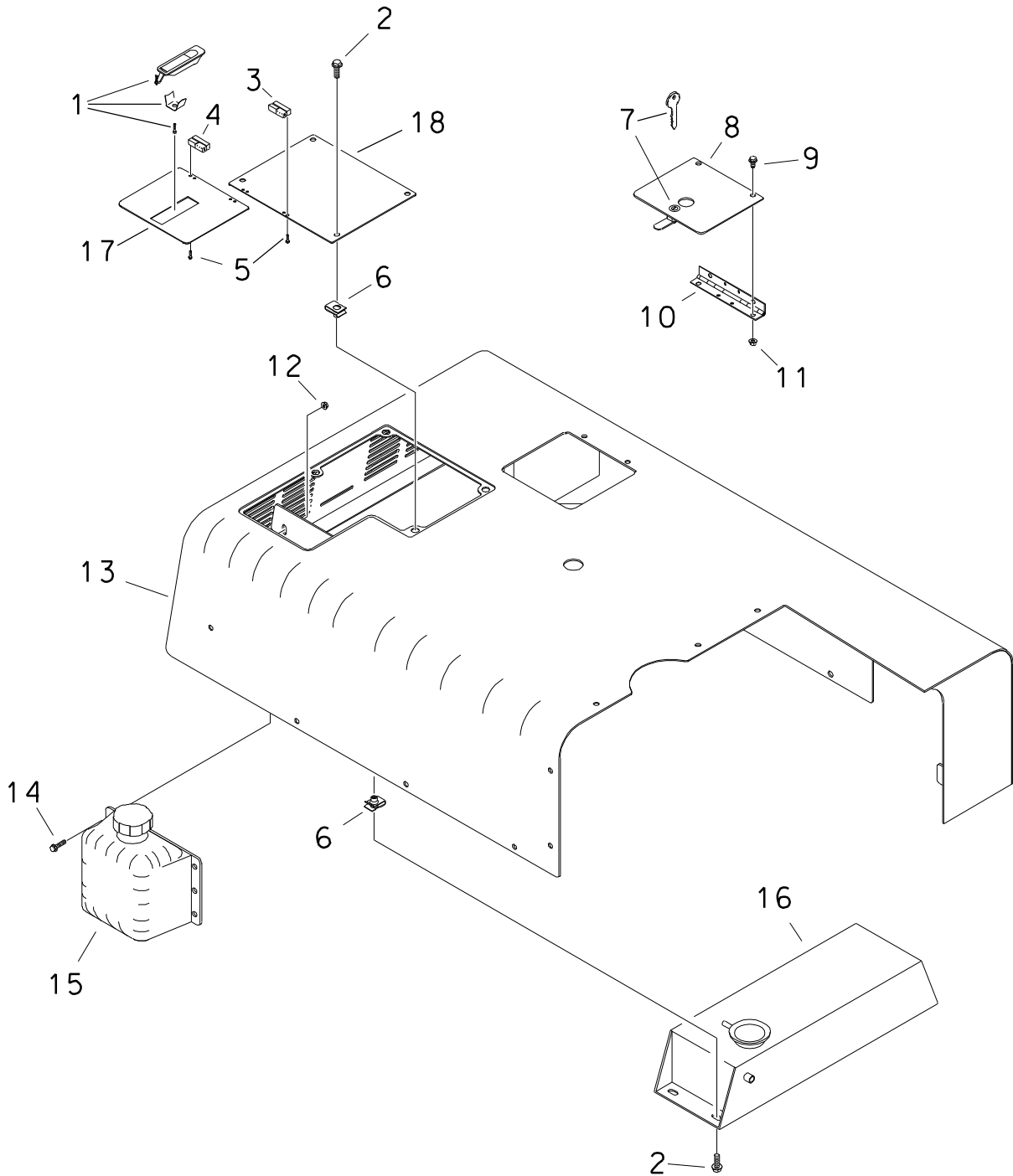

## COOLANT SYSTEM MOUNTING

BEGINS WITH S/N 2X0001

REF NO.	PART NUMBER	QTY	DESCRIPTION	REMARKS
1.	117-558	1	ADJUST LEVER LATCH (LOCKING)	BEGINS WITH S/N 2X0001
	214-961		KEY, PAIR (BASE CODE)	
	217-309		LOCK PLUG 4/LATCH (BASE CODE)	
	<u>110-757</u>	1	LEVER LATCH (ADJUST, LOCKING)	
2.	106-991	8	FLG LK SCREW (M8-1.25 X 20MM)	
3.	111-051	1	HINGE	
4.	111-052	1	HINGE	
5.	105-650	8	SCREW (M4-0.70 X 10MM)	
6.	106-551	8	CLIP NUT (M8-1.25)	
7.	117-915	1	CAM LOCK (BASE CODE)	
	214-961		KEY, PAIR (BASE CODE)	
	<u>110-711</u>	1	CAM LOCK	INCL KEYS
	217-844		KEYS (PAIR)	
8.	194-157	1	RADIATOR DOOR	
9.	105-836	4	FLG LOCK BOLT (1/4-NC X 1/2")	
10.	110-580	1	HINGE (6")	
11.	105-832	4	FLG LOCKNUT (1/4-NC)	
12.	106-385	2	FLG LOCKNUT (M6-1.00)	
13.	310-785	1	TOP COVER (REAR)	
14.	106-161	2	FLG SCREW (M6-1.00 X 20MM)	
15.	364-229	1	OVERFLOW TANK (3 QT)	
16.	364-543	1	EXPANSION TANK	
17.	354-581	1	DOOR PANEL	
18.	310-791	1	PLATE	

FOOTNOTES

# SOUND INSULATION TOP COVER (REAR)

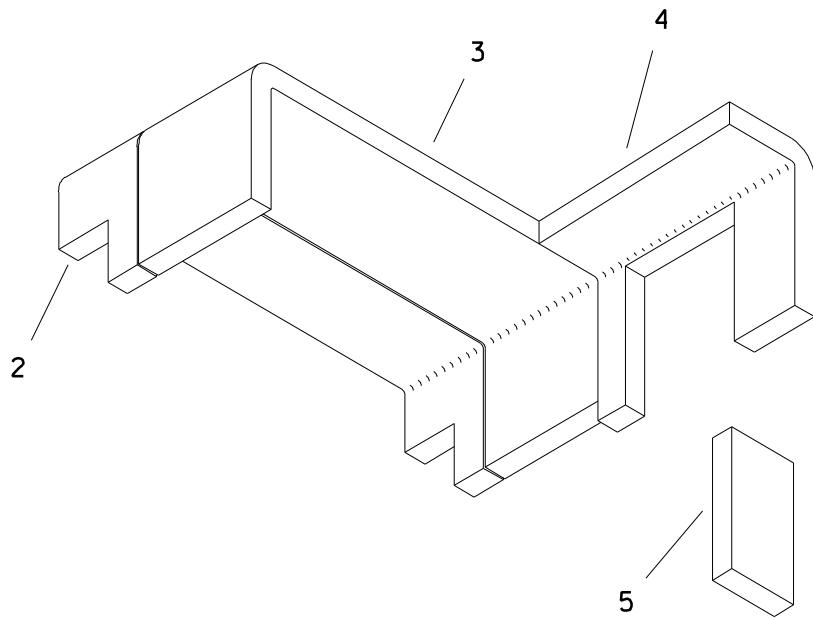
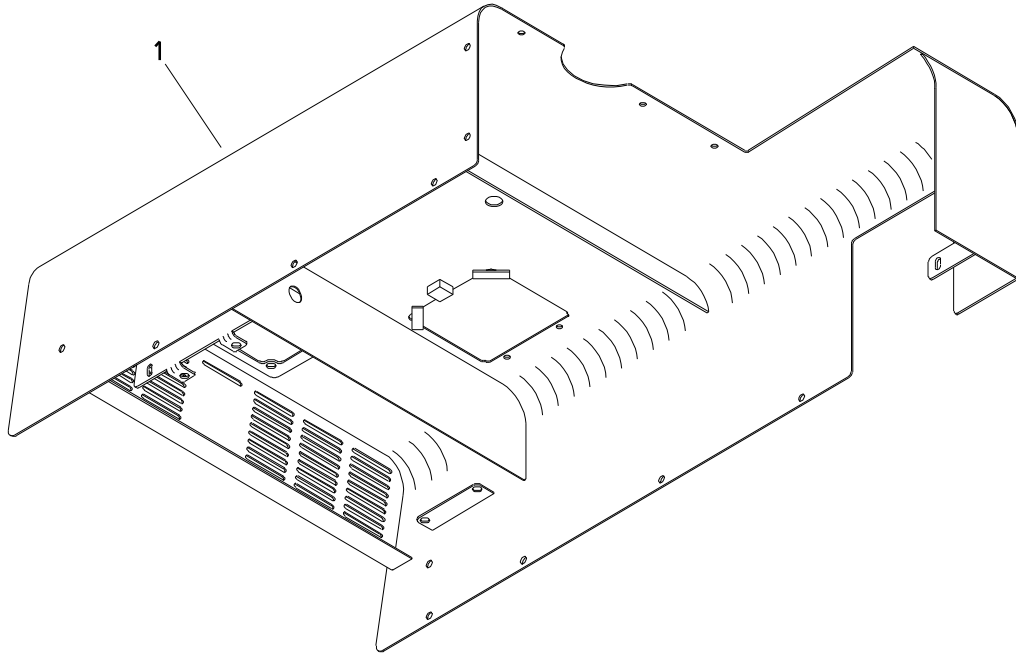

SOUND INSULATION  
TOP COVER (REAR)

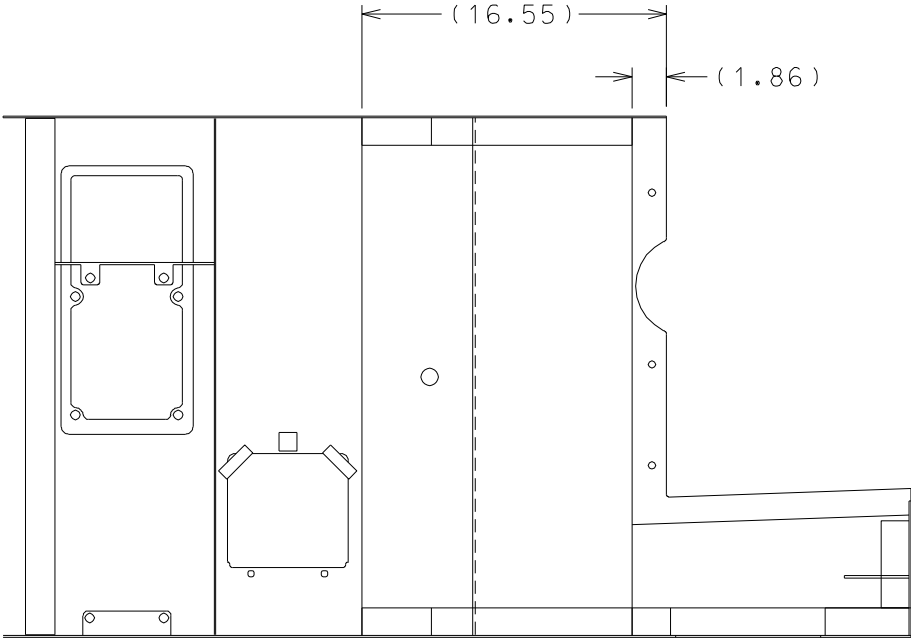
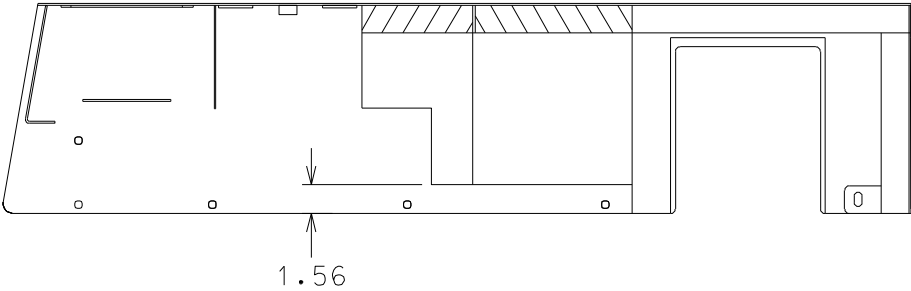

# SOUND INSULATION TOP COVER (REAR)

REF NO.	PART NUMBER	QTY	DESCRIPTION	REMARKS
1.	310-785	-	TOP COVER (REAR)	
2.	343-950	1	NOISE BARRIER, REAR TOP PANEL	
3.	117-318	1	NOISE BARRIER, REAR TOP PANEL	
4.	117-452	1	NOISE BARRIER, AIR DUCT	
5.	117-453	1	NOISE BARRIER, END	

FOOTNOTES



# RELAY PANEL JT2720 MACH 1 ONLY 1

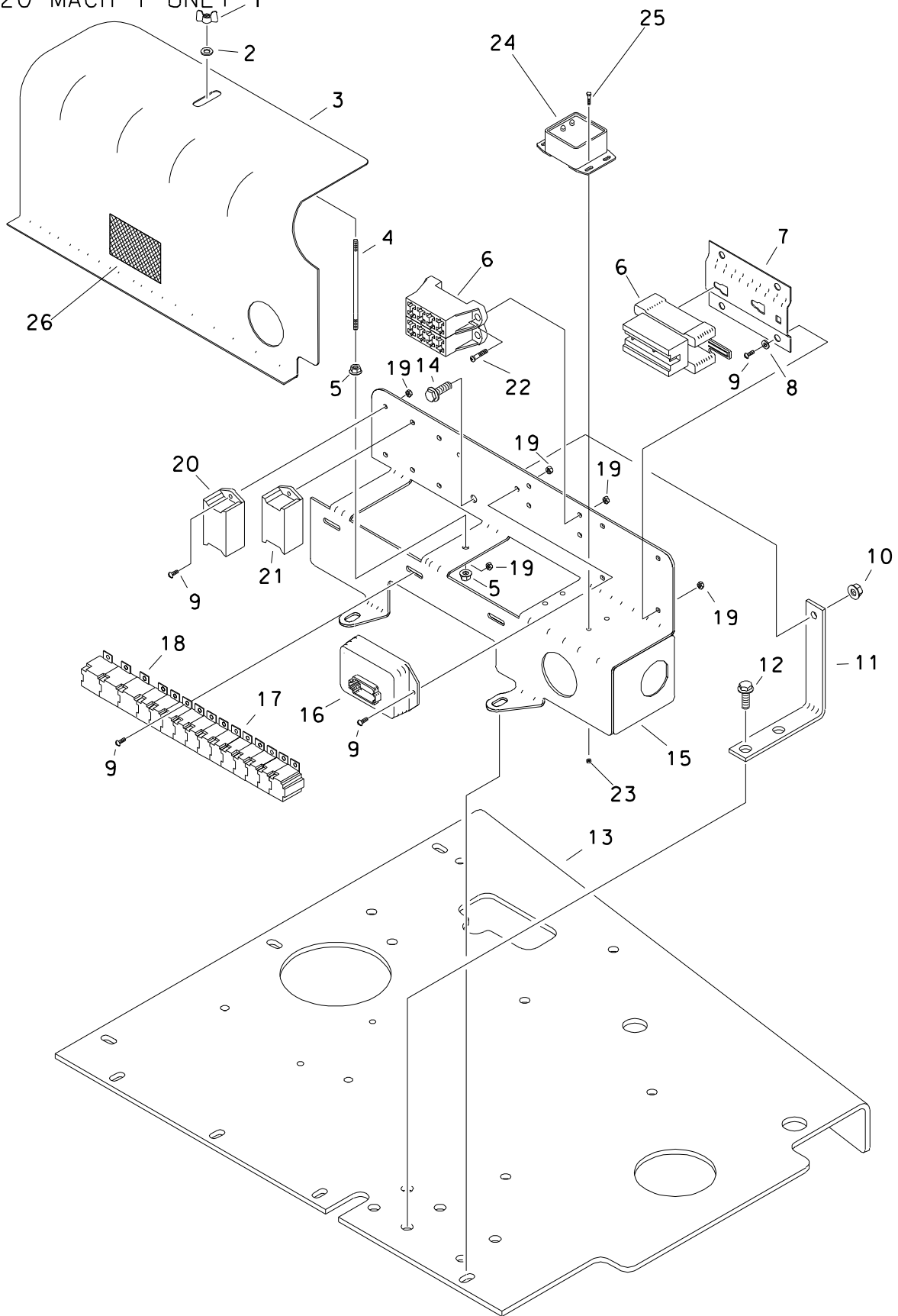



# RELAY PANEL

## JT2720 MACH 1 ONLY

REF NO.	PART NUMBER	QTY	DESCRIPTION	REMARKS
1.	195-339	1	WING NUT (1/4-NC)	
2.	105-095	1	WASHER (1/4")	
3.	308-957	1	RELAY PANEL COVER	
4.	106-289	1	STUD BOLT (1/4-NC X 5", GD8)	
5.	105-832	2	FLG LOCKNUT (1/4-NC)	
6.	214-746	1	RELAY/ENGINE HARNESS	
7.	353-135	1	FUSE PLATE ADAPTER	
8.	105-284	4	WASHER (3/16")	
9.	105-185	14	BOLT (#10-24 X 1/2", RD SLT)	
10.	106-386	1	FLG LOCKNUT (M8-1.25)	
11.	343-335	1	RELAY PANEL BRACKET	
12.	106-724	2	FLG SCREW (M10-1.50 X 25MM)	
13.	305-677	1	PLATE, BATTERY SUPPORT	
14.	106-162	1	FLG SCREW (M8-1.25 X 20MM)	
15.	309-824	1	RELAY PANEL	
16.	211-031	1	BORE/MOBILE RESISTOR PACK	
17.	217-710	12	MICRO RELAY (SPDT)	
18.	217-826	3	MINI RELAY (SPDT)	
19.	106-048	14	LOCKNUT (#10-24)	
20.	217-937	1	START BYPASS DELAY TIMER	
21.	217-184	1	DELAY TIMER (2-SECOND)	
22.	106-049	4	BOLT (#10-24 X 3/4", PLPS)	
23.	105-215	4	NUT (#6-32)	
24.	211-017	1	12V-5V VOLTAGE CONVERTOR	
25.	105-189	4	SCREW (#6-32 X 1/2")	
26.	273-236	-	ENGINE ELECTRICAL CENTER	

FOOTNOTES

# RELAY PANEL

JT2720 MACH 1 ALL TERRAIN ONLY

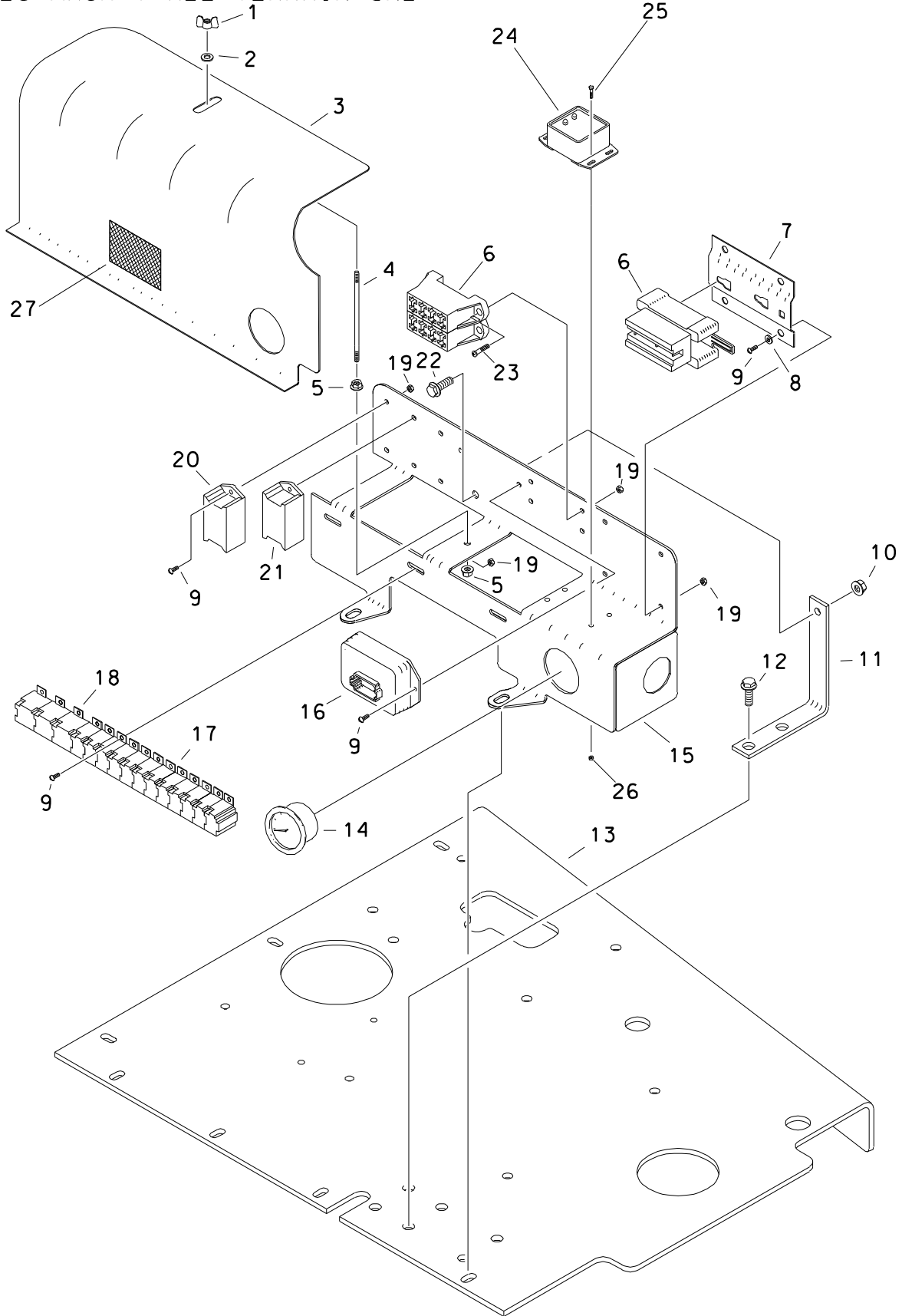

# RELAY PANEL JT2720 MACH 1 ALL TERRAIN ONLY

REF NO.	PART NUMBER	QTY	DESCRIPTION	REMARKS
1.	195-339	1	WING NUT (1/4-NC)	
2.	105-095	1	WASHER (1/4")	
3.	308-957	1	RELAY PANEL COVER	
4.	106-289	1	STUD BOLT (1/4-NC X 5", GD8)	
5.	105-832	2	FLG LOCKNUT (1/4-NC)	
6.	214-746	1	RELAY/ENGINE HARNESS	
7.	353-135	1	FUSE PLATE ADAPTER	
8.	105-284	4	WASHER (3/16")	
9.	105-185	14	BOLT (#10-24 X 1/2", RD SLT)	
10.	106-386	1	FLG LOCKNUT (M8-1.25)	
11.	343-335	1	RELAY PANEL BRACKET	
12.	106-724	2	FLG SCREW (M10-1.50 X 25MM)	
13.	305-677	1	PLATE, BATTERY SUPPORT	
14.	215-128	1	HOUR METER	
15.	309-824	1	RELAY PANEL	
16.	211-031	1	BORE/MOBILE RESISTOR PACK	
17.	217-710	12	MICRO RELAY (SPDT)	
18.	217-826	3	MINI RELAY (SPDT)	
19.	106-048	17	LOCKNUT (#10-24)	
20.	217-937	1	START BYPASS DELAY TIMER	
21.	217-184	1	DELAY TIMER (2-SECOND)	
22.	106-162	1	FLG SCREW (M8-1.25 X 20MM, GD8)	
23.	106-049	4	BOLT (#10-24 X 3/4", PLPS)	
24.	211-017	1	12V-5V VOLTAGE CONVERTOR	
25.	105-189	4	SCREW (#6-32 X 1/2")	
26.	105-215	4	NUT (#6-32)	
27.	273-236	-	ENGINE ELECTRICAL CENTER	

FOOTNOTES

# BATTERY SUPPORT

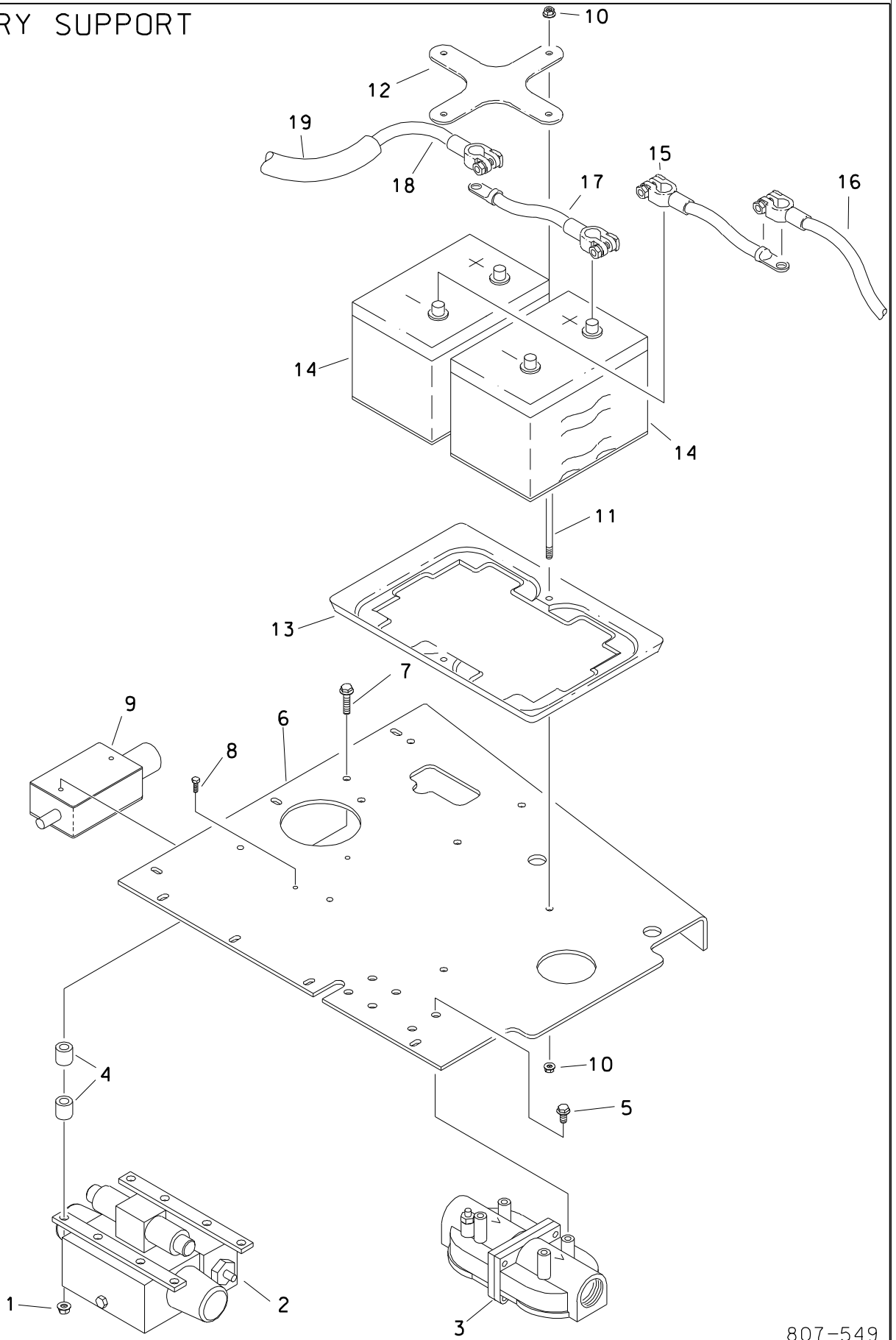

# BATTERY SUPPORT

REF NO.	PART NUMBER	QTY	DESCRIPTION	REMARKS
1.	105-894	4	LOCKNUT (M10-1.50, PRV TRQ,10.9)	
2.	153-543	1	THRUST VALVE (ELECTRIC)	
3.	159-411	1	FILTER HEAD (20SF-20SF)	
	168-616	-	FILTER HEAD GASKET	
	149-840	2	FILTER ELEMENT (1-1/2-UNF)	SEE FOOTNOTE 1
	159-079	2	FILTER ELEMENT (1-1/2-UNF)	SEE FOOTNOTE 2
4.	178-011	8	BOSS	
5.	105-825	4	FLG LK BOLT (3/8-NC X 3/4")	
6.	305-677	-	PLATE, BATTERY SUPPORT	
7.	106-617	4	SCREW (M10-1.50 X 80MM)	
8.	105-865	2	BOLT (1/4-NC X 3/4", GD8)	
9.	215-231	1	LINEAR ACTUATOR	
	196-058	1	CABLE SWIVEL (.081")	
	196-331	1	CABLE (LINEAR ACTUATOR)	
	214-299	1	ACTUATOR PIGTAIL	
10.	105-832	4	FLG LOCKNUT (1/4-NC)	
11.	356-491	2	TIE-DOWN ROD (1/4-NC X 9.3")	
12.	356-490	1	BATTERY PLATE	
13.	362-784	1	BATTERY TRAY	
14.	215-244	2	BATTERY	
15.	215-350	1	BAT CABLE (2 GA X 8", BLK)	
16.	215-337	1	BAT CABLE (2/0 GA X 19", BLK)	
17.	215-349	1	BAT CABLE (2 GA X 8", RED)	
18.	215-317	1	BAT CABLE (2/0 GA X 54", RED)	
19.	116-389	1	BULK TUBING (3/4", SOLD PER 1')	USE 1 @ 48"

## FOOTNOTES

- USE 149-840 ELEMENT AFTER HOSE OR COMPONENT REPLACEMENT OR REPAIR
- REPLACE WITH 159-079 AFTER FIRST 50 HOURS.



# **OPERATOR'S STATION**

STEP

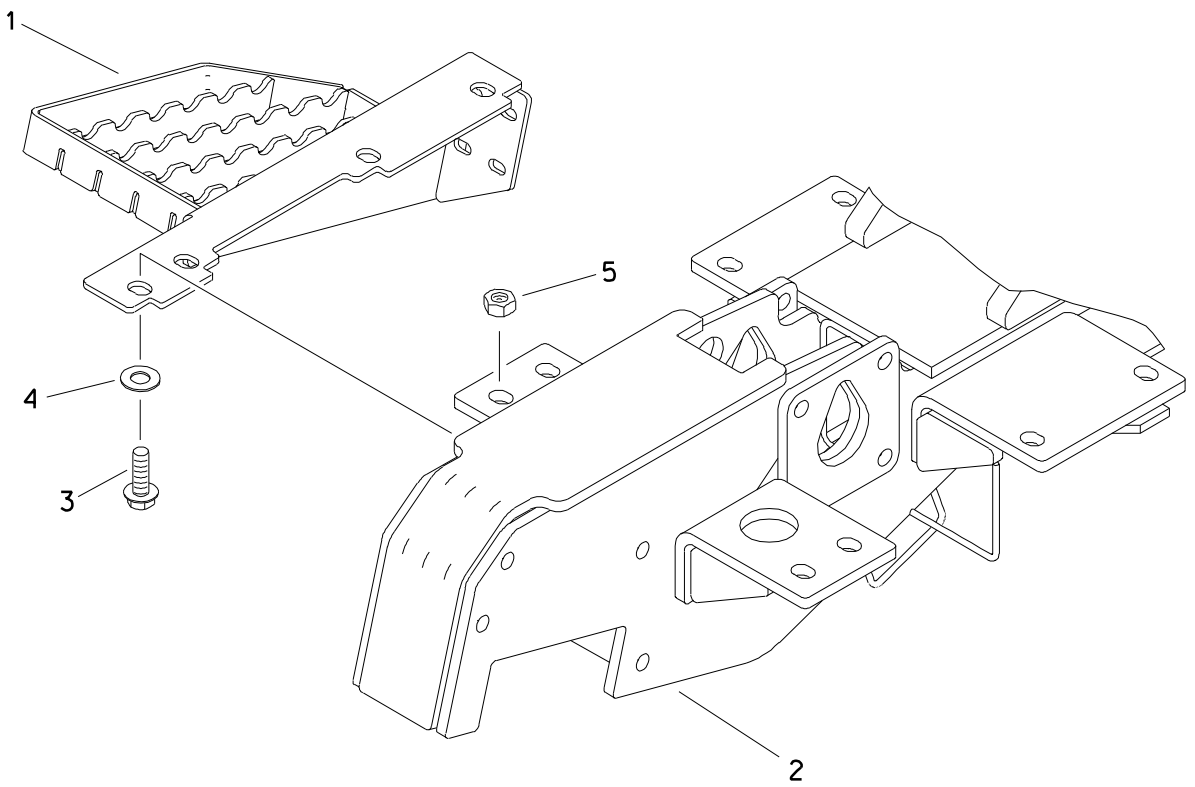



# STEP

REF NO.	PART NUMBER	QTY	DESCRIPTION	REMARKS
1.	303-960	1	STEP	
2.	303-648	-	DRILL FRAME	
3.	106-616	1	SCREW (M16-2.00 X 55MM, 10.9)	
4.	106-398	1	WASHER (M16, HARDENED)	
5.	106-545	1	LOCKNUT (M16-2.0,PRV TRQ,10.9)	

## FOOTNOTES

# SEAT MOUNT

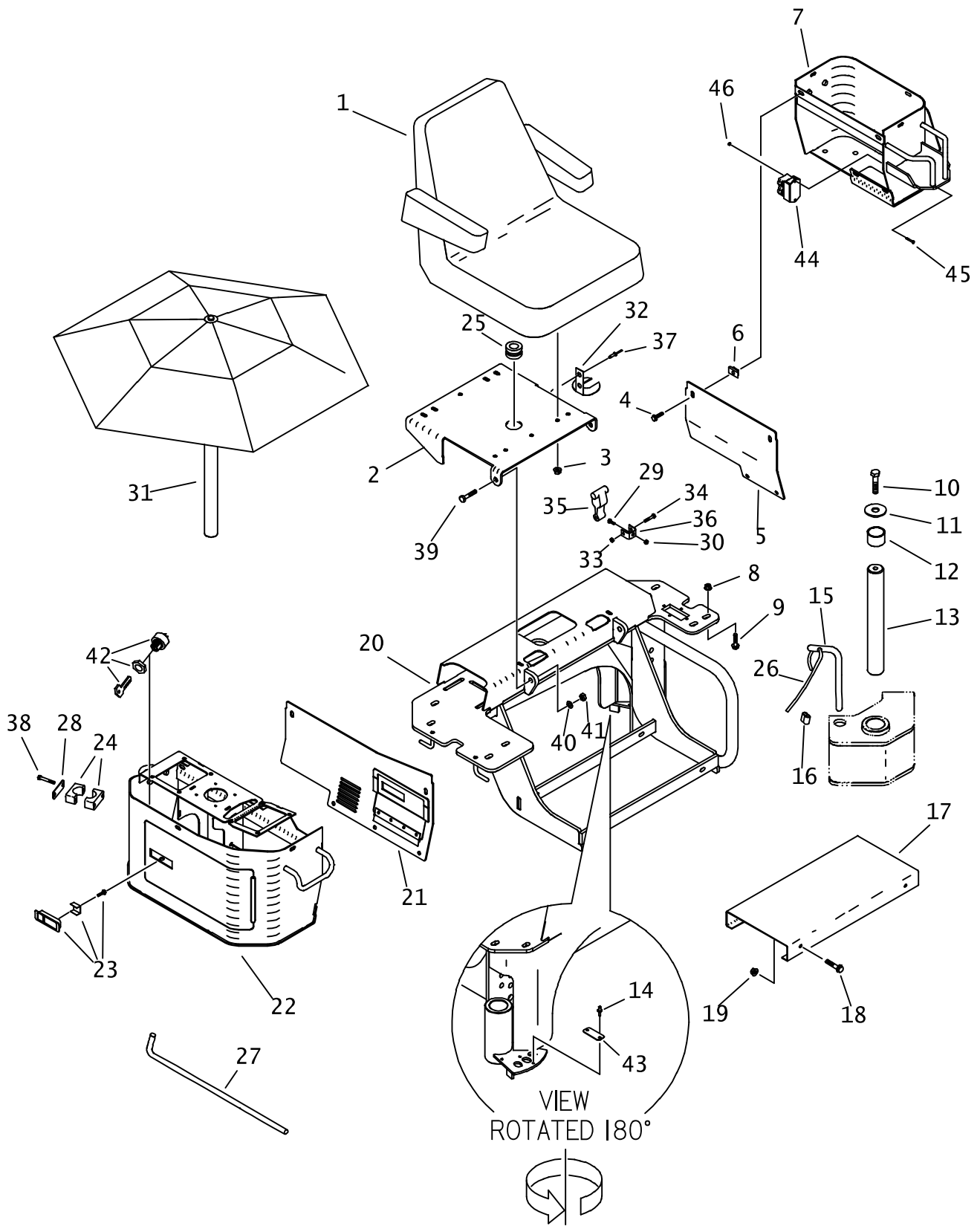

## SEAT MOUNT

REF NO.	PART NUMBER	QTY	DESCRIPTION	REMARKS
1.	<u>117-439</u>	1	SEAT ASS'Y W/ ARM REST	
	<u>117-572</u>		SEAT CUSHION W/SWITCH	
	117-914	1	SEAT ASS'Y W/ ARM REST	
	117-912		SEAT CUSHION ASSM'Y W/SWITCH	
	214-964		SEAT SWITCH W/ BOOT	
	214-965		SEAT SWITCH HARNESS	
	117-573		BACK CUSHION	
	191-170		L. ARMREST KIT	
	191-171		R. ARMREST KIT	
	191-172		SEAT SLIDE KIT	
2.	310-634	1	SEAT PLATE	
3.	105-003	4	FLG LOCKNUT (5/16-NC)	
4.	107-095	9	FLG SCREW (M8-1.25 X 16MM)	
5.	348-694	1	LEFT COVER	
6.	106-551	9	CLIP NUT (M8-1.25)	
7.	211-004	1	LEFT CONSOLE	
8.	105-833	8	FLG LOCKNUT (1/2-NC)	
9.	106-413	8	CARRIAGE BOLT (1/2-NC X 1")	
10.	107-206	2	SCREW (M12-1.75 X 35MM)	LOCTITE 277
11.	105-057	2	WASHER (9/16")	
12.	125-739	4	COMPOSITION BUSHING (1.756")	
13.	179-240	1	PIN	
14.	110-348	2	POP RIVET (3/16" X .664")	USE ON JT1720 ONLY
15.	179-244	1	PIN	
16.	350-275	2	ALUMINUM SLEEVE (1/16")	
17.	348-695	1	FLOOR TREAD	
18.	106-992	4	FLG LK SCREW (M8-1.25 X 25MM)	
19.	106-386	4	FLG LOCKNUT (M8-1.25)	
20.	348-711	1	SEAT MOUNT	
21.	309-234	1	RIGHT COVER	
22.	303-956	1	RIGHT CONSOLE	
	314-591	-	RIGHT CONSOLE ACCESS DOOR	
23.	117-558	2	ADJUST LEVER LATCH (LOCKING)	BEGINS WITH S/N: 2X0106
	214-961		KEY, PAIR (BASE CODE)	
	217-309		LOCK PLUG 4/LATCH (BASE CODE)	
	<u>110-757</u>	2	LEVER LATCH (ADJUST, LOCKING)	INCL KEYS
	110-596	-	KEY (PAIR)	
24.	111-026	2	BOLT-ON CLAMP (1-1/4", PAIR)	
25.	115-320	1	GROMMET (1-1/2")	
26.	110-981	AR	BULK CABLE (1/16",SOLD PER 1')	USE 1 @ 12"
27.	215-799	1	VOLTAGE STAKE	
28.	322-362	2	BACKUP SPACER	
29.	105-806	1	SCREW (M8-1.25 X 25MM)	
30.	107-096	1	LOCKNUT (M8-1.25, NLK)	

FOOTNOTES:

NOTE:

## SEAT MOUNT

REF NO.	PART NUMBER	QTY	DESCRIPTION	REMARKS
31.	344-0001	1	UMBRELLA (6.5')	
	500-1962	-	UMBRELLA POLE (16")	
32.	110-223	1	LATCH BRACKET	
33.	106-237	1	LOCKNUT (M6-1.00,PRV TRQ,NLK)	
34.	106-093	1	SCREW (M6-1.00 X 45MM)	
35.	110-222	1	HOOD LATCH	
36.	110-224	1	ANCHOR BRACKET	
37.	110-253	2	POP RIVET (3/16" X 1/2")	
38.	105-297	4	BOLT (1/4-NC X 3-1/4")	
39.	106-739	2	SHLD BLT (M12 X 20MM,M10-1.50)	
40.	106-391	2	WASHER (M12)	
41.	106-758	2	LOCKNUT (M10-1.50)	
42.	214-908	1	OFF-ON KEY SWITCH	
43.	310-612	1	PIVOT PLATE COVER	USE ON JT1720 ONLY
44.	211-026	1	DIODE PACK (DEUTSCH)	
45.	106-049	1	BOLT (#10-24 Xf", PLPS)	
46.	106-048	1	LOCKNUT (#10-24)	

FOOTNOTES:

NOTE:



# OPERATORS STATION GAUGES

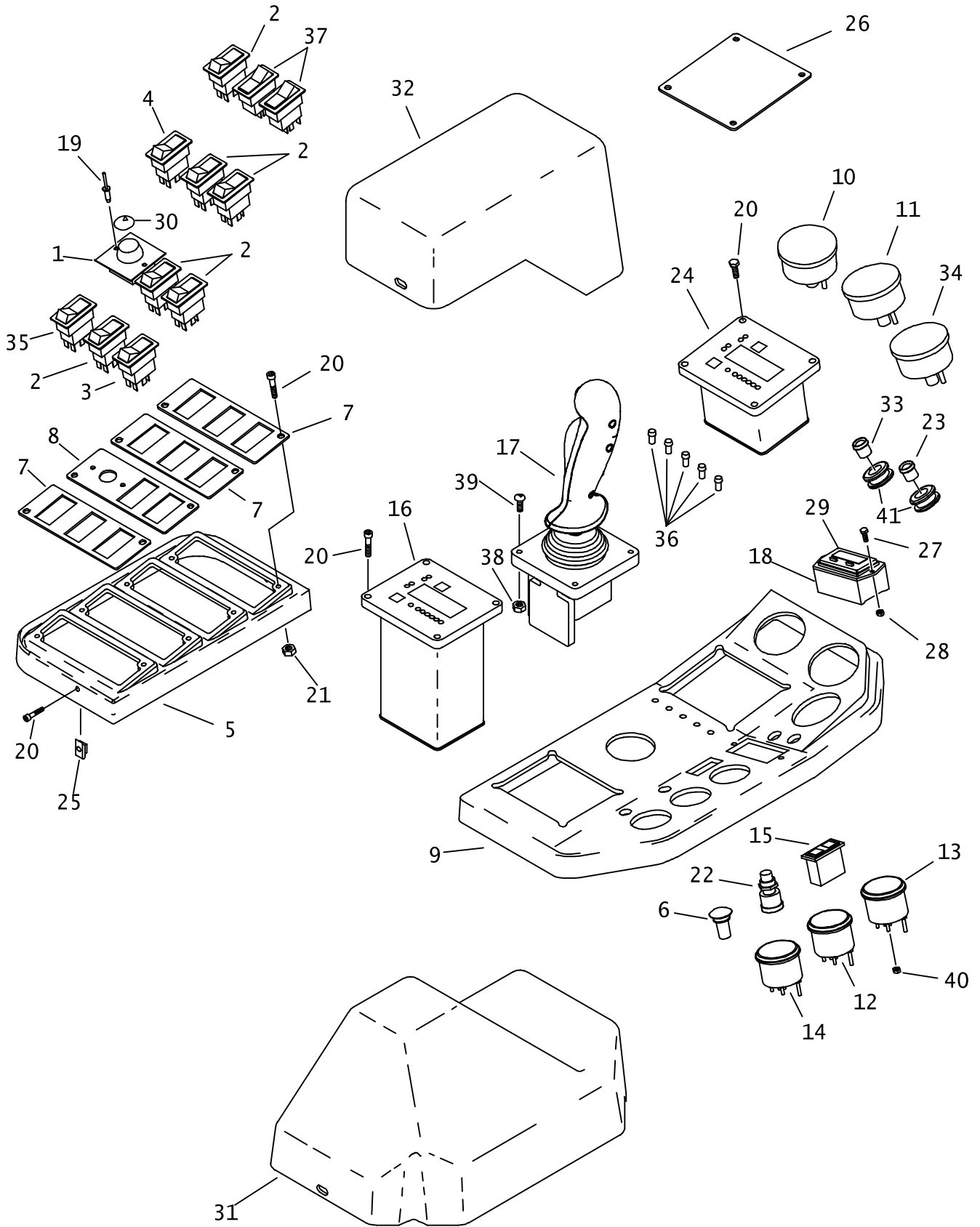

## OPERATORS STATION GAUGES

REF NO.	PART NUMBER	QTY	DESCRIPTION	REMARKS
1.	214-566	1	POTENTIOMETER	
2.	214-489	6	ROCKER SW (DPDT) (ON)-OFF-(ON)	
3.	217-916	1	ROCKER SWITCH (DPDT) ON-OFF-ON	
4.	217-911	1	ROCKER SWITCH (SPDT) ON-OFF-ON	
5.	211-009	1	LEFT CONSOLE COVER	
6.	217-724	1	BUTTON SWITCH (SPST)	
	217-206	1	BUTTON SWITCH (SPST)	
	214-943	1	BUTTON SWITCH (SPST)	
	215-754	1	MC INSULATOR (2-TERMINAL)	
7.	362-929	3	SWITCH PANEL	
8.	362-931	1	SWITCH PANEL	
9.	211-014	1	RIGHT CONSOLE COVER	
10.	258-045	1	GAUGE (4000 PSI)	
11.	258-036	1	HYD PRESSURE GAUGE (6000 PSI)	
12.	215-131	1	OIL PRESSURE GAUGE	
	215-415	1	NITE-LIGHT KIT (12V DC)	OPTION
13.	258-037	1	WATER TEMPERATURE GAUGE	
14.	215-133	1	FUEL GAUGE	
	215-415	1	NITE-LIGHT KIT (12V DC)	OPTION
15.	217-020	1	PILOT LIGHT	
	217-027	1	INSERT (RED) HYD OIL HI TEMP	
	217-036	1	INSERT (YELLOW) HYD OIL PSI	
	217-074	2	LENS REFLECTOR	
	217-046		BULB (12V DC)	
16.	217-241	1	ESID MODULE	
17.	215-1224	1	DUAL AXIS JOYSTICK	
	197-104		REMANUFACTURED 214-565 JYSTK	
18.	217-221	1	FLOW METER DISPLAY	
19.	110-560	2	POP RIVET (3/16" X 1/2", ALUM)	
20.	106-640	19	BOLT (M6-1.00 X 20MM, BUT SOC)	
21.	106-237	8	LOCKNUT (M6-1.00, PRV TRQ, NLK)	
22.	306-607	1	HORN BUTTON	
	306-608	1	BUTTON COVER	
23.	214-840	1	GREEN LED (12V DC)	
24.	N/A	1	REMOTE DISPLAY	
25.	106-574	3	CLIP NUT (M6-1.00)	
26.	348-896	1	COVER PLATE	FOR UNITS WITHOUT REMOTE DISPLAY
27.	501-343	2	BOLT (#10-24 X 1/2", SOC)	
28.	106-048	2	LOCKNUT (#10-24)	
29.	319-412	1	FLOW METER WEATHER COVER	

NOT SHOWN:

319-412 1 FLOW METER WEATHER COVER

## OPERATORS STATION GAUGES

REF NO.	PART NUMBER	QTY	DESCRIPTION	REMARKS
30.	274-940	1	INDICATOR	
31.	348-960	1	RIGHT CONSOLE COVER	
32.	310-184	1	LEFT CONSOLE COVER	
33.	214-563	1	RED LED 12V	
34.	150-1444	1	PRESSURE GAUGE (2000PSI)	
35.	217-912	1	ROCKER SWITCH (DPDT) ON-ON-ON	
36.	214-701	5	STATUS LIGHT	
37.	217-908	2	ROCKER SWITCH DPDT ON-ON-(ON)	JT27M1 & AT27M1
	214-489	2	ROCKER SW (DPDT) (ON)-OFF-(ON)	JT17M1
38.	105-186	4	NUT (#10-24)	
39.	105-815	4	BOLT (#10-24 X 1", PAN SLT)	
40.	105-215	6	NUT (#6-32)	
41.	116-203	AR	GROMMET (9/16")	

NOT SHOWN:





# DUAL AXIS JOYSTICK

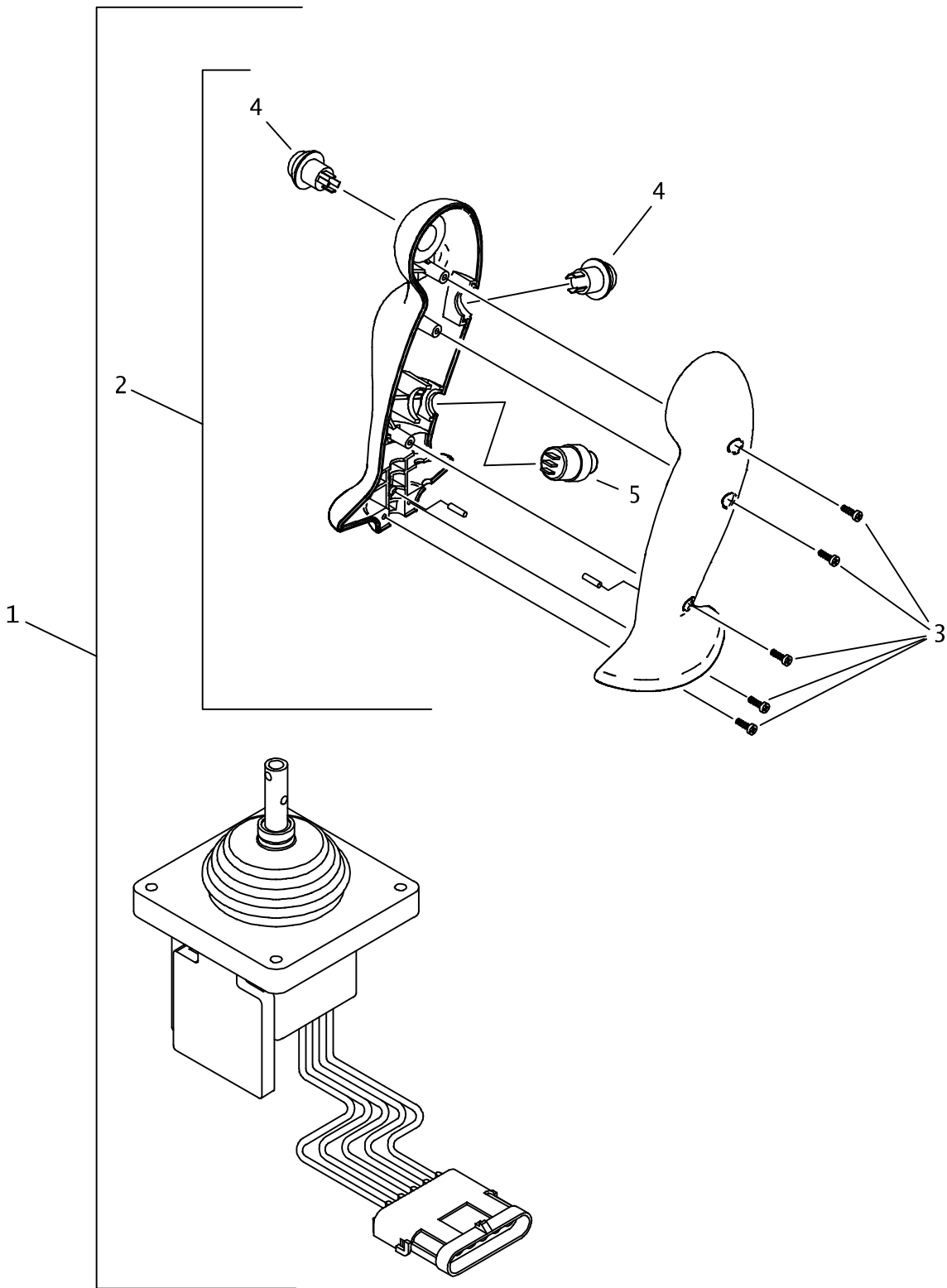

# DUAL AXIS JOYSTICK

REF NO.	PART NUMBER	QTY	DESCRIPTION	REMARKS
1.	215-1224	-	DUAL AXIS JOYSTICK	
2.	500-1433	-	JOYSTICK HANDLE ASSEMBLY	INCLUDES REF No's 3,4,& 5
3.	107-410	-	SCREW (#2.5 X 8", PAN, PLASTIC)	
4.	214-614	-	PUSHBUTTON SW (SPST) OFF-(ON)	
5.	214-616	-	PUSHBUTTON SW (SPDT) ON-ON	

NOT SHOWN:

FOOTNOTES:

NOTE:

# RIGHT CONSOLE ELECTRICAL

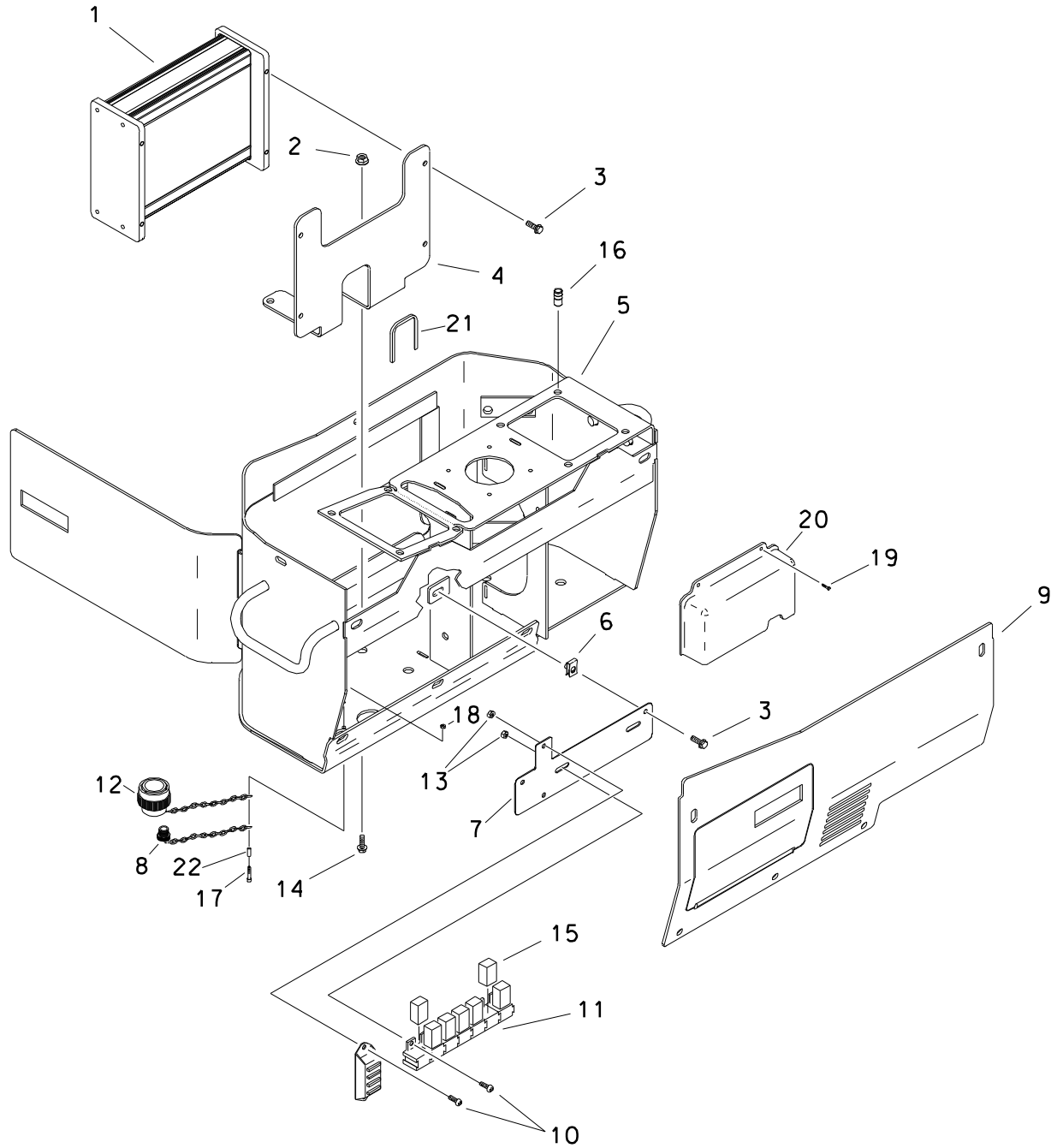

# RIGHT CONSOLE ELECTRICAL

REF NO.	PART NUMBER	QTY	DESCRIPTION	REMARKS
1.	216-059	1	CONTROL MODULE	
2.	106-386	2	FLG LOCKNUT (M8-1.25)	
3.	106-378	6	FLG LK SCREW (M6-1.00 X 12MM)	
4.	305-990	1	BRACKET, CONTROLLER	
5.	303-956	-	RIGHT CONSOLE	
6.	106-574	2	CLIP NUT (M6-1.00)	
7.	315-439	1	RELAY PANEL	
8.	211-078	1	CONNECTOR CAP (TURCK RS-CC)	
9.	309-234	-	RIGHT COVER	
10.	106-049	4	BOLT (#10-24 X 3/4", PLPS)	
11.	214-741	1	CONSOLE HARNESS	
	110-930	1	SPIRAL WRAP (1.5", SOLD PER FT)	1 @ 50"
12.	214-812	1	PROTECTIVE CAP	
13.	106-048	4	LOCKNUT (#10-24)	
14.	106-380	2	FLG LK SCREW (M8-1.25 X 16MM)	
15.	217-710	7	MICRO RELAY (SPDT)	
16.	106-670	8	NUTSERT (M6-1.00)	
17.	107-269	4	SCREW (#4-40 X 3/4", PAN)	
18.	105-662	4	NUT (#4-40)	
19.	105-214	2	FLG SCREW (#10-24 X 1/2")	
20.	315-410	1	RELAY COVER	
21.	115-686	-	BULK EDGE (5/32", SOLD PER 1')	1 @ 2.5'
22.	350-275	1	ALUMINUM SLEEVE (1/16")	

FOOTNOTES

# AUXILIARY CONSOLE

JT2720 MACH 1 ONLY

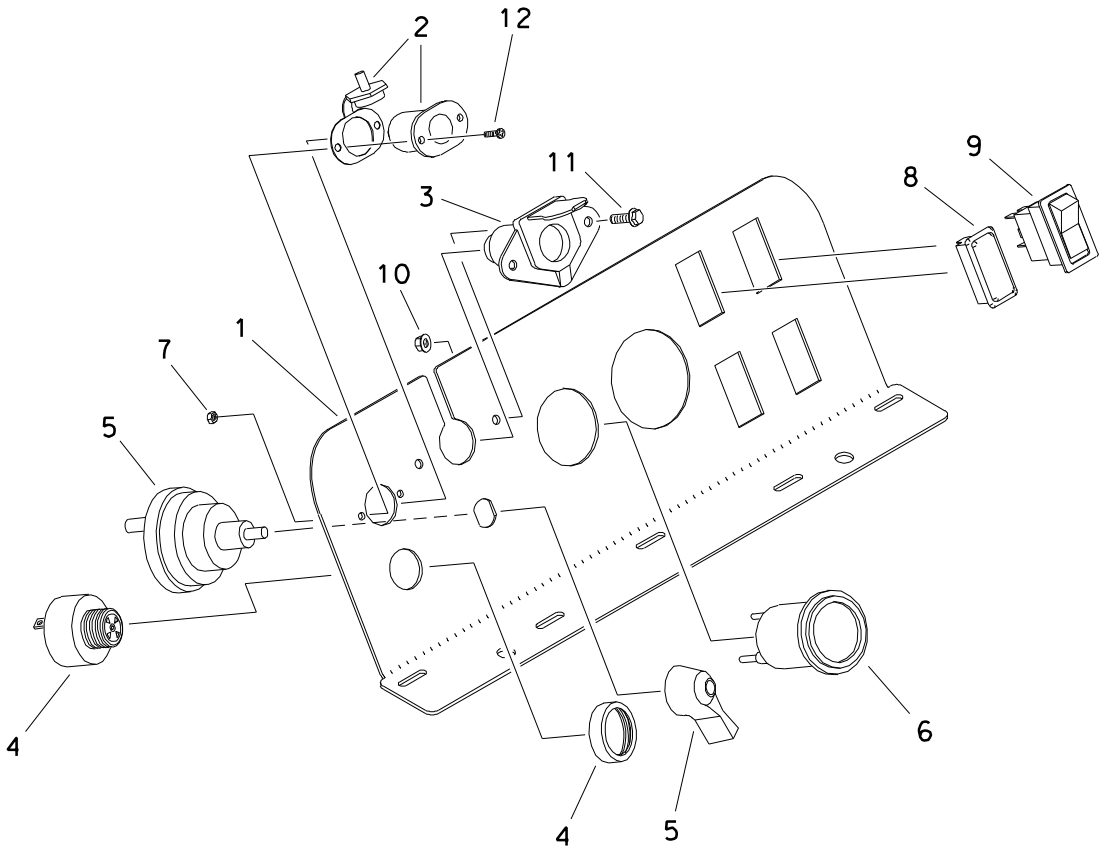

# AUXILIARY CONSOLE JT2720 MACH 1 ONLY

REF NO.	PART NUMBER	QTY	DESCRIPTION	REMARKS
1.	305-847	1	PANEL ENGINE CONSOLE	
2.	214-301	1	ACCESSORY SOCKET	
3.	217-017	1	CONNECTOR (4-WAY, FM)	
4.	306-603	1	AUDIO ALARM	
5.	217-819	1	BAT DISCONNECT SWITCH	
6.	211-070	1	TACHOMETER (3000 RPM)	
7.	105-215	2	BOLT (3/8-NC X 4-1/2")	
8.	110-962	3	FILLER PLUG	
9.	217-907	1	ROCKER SWITCH (DPDT) ON-ON	
10.	106-385	1	FLG LOCKNUT (M6-1.00)	
11.	106-379	1	FLG LK SCREW (M6-1.00 X 20MM)	
12.	106-273	2	SCREW (#6-32 X 5/8", FLT, BRASS)	

FOOTNOTES

# AUXILIARY CONSOLE

JT2720 MACH 1 ALL TERRAIN ONLY

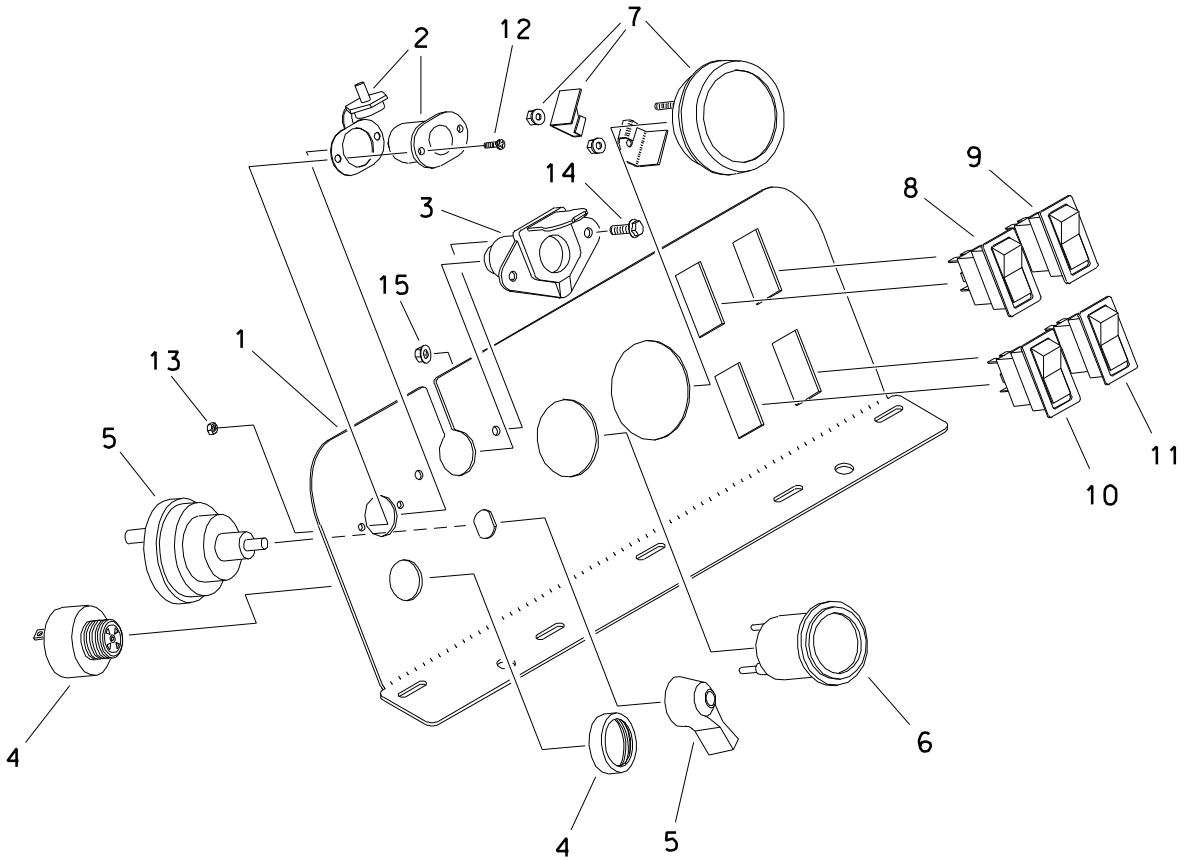



**AUXILIARY CONSOLE**  
**JT2720 MACH 1 ALL TERRAIN ONLY**

REF NO.	PART NUMBER	QTY	DESCRIPTION	REMARKS
1.	305-847	1	PANEL ENGINE CONSOLE	
2.	214-301	1	ACCESSORY SOCKET	
3.	217-017	1	CONNECTOR (4-WAY, FM)	
4.	306-603	1	AUDIO ALARM	
5.	217-819	1	BAT DISCONNECT SWITCH	
6.	211-070	1	TACHOMETER (3000 RPM)	
7.	258-036	1	HYD PRESSURE GAUGE (6000 PSI)	
8.	217-907	1	ROCKER SWITCH (DPDT) ON-ON	
9.	217-907	1	ROCKER SWITCH (DPDT) ON-ON	
10.	217-908	1	ROCKER SWITCH (DPDT) ON-ON-ON	
11.	217-911	1	ROCKER SWITCH (SPDT) ON-OFF-ON	
12.	106-273	2	SCREW (#6-32 X 5/8", FLT, BRASS)	
13.	105-215	2	BOLT (3/8-NC X 4-1/2")	
14.	106-379	2	FLG LK SCREW (M6-1.00 X 20MM)	
15.	106-385	2	FLG LOCKNUT (M6-1.00)	

FOOTNOTES

AUXILIARY CONSOLE  
JT2720 MACH 1 ALL TERRAIN ONLY  
BEGINS WITH S/N 2V1745

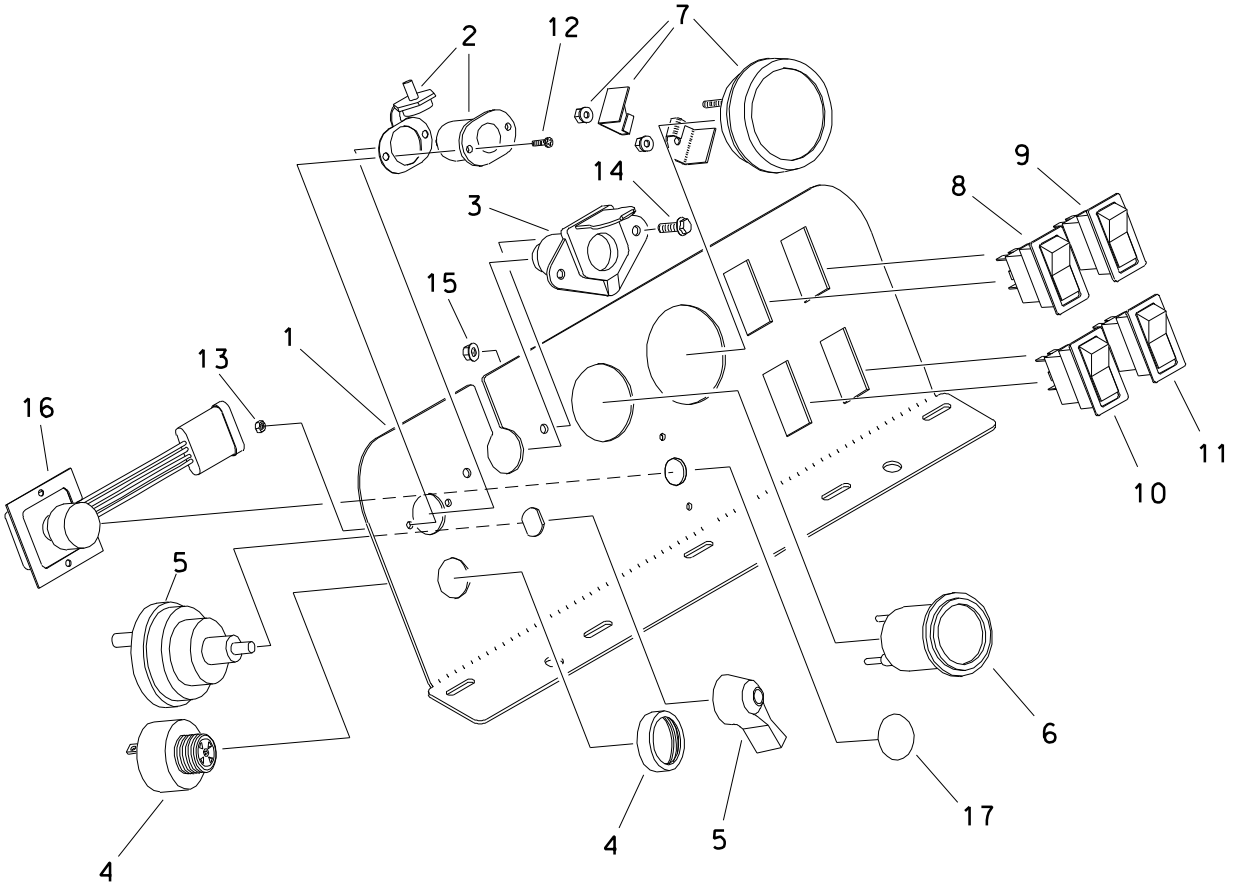

**AUXILIARY CONSOLE**  
**JT2720 MACH 1 ALL TERRAIN ONLY**  
**BEGINS WITH S/N 2V1745**

REF	PART				
NO.	NUMBER	QTY	DESCRIPTION		REMARKS
1.	305-847	1	PANEL ENGINE CONSOLE		
2.	214-301	1	ACCESSORY SOCKET		
3.	217-017	1	CONNECTOR (4-WAY, FM)		
4.	306-603	1	AUDIO ALARM		
5.	217-819	1	BAT DISCONNECT SWITCH		
6.	211-070	1	TACHOMETER (3000 RPM)		
7.	258-036	1	HYD PRESSURE GAUGE (6000 PSI)		
8.	217-907	1	ROCKER SWITCH (DPDT) ON-ON		
9.	217-907	1	ROCKER SWITCH (DPDT) ON-ON		
10.	217-908	1	ROCKER SWITCH (DPDT) ON-ON-ON		
11.	217-911	1	ROCKER SWITCH (SPDT) ON-OFF-ON		
12.	106-273	4	SCREW (#6-32 X 5/8", FLT, BRASS)		
13.	105-215	4	BOLT (3/8-NC X 4-1/2")		
14.	106-379	2	FLG LK SCREW (M6-1.00 X 20MM)		
15.	106-385	2	FLG LOCKNUT (M6-1.00)		
16.	211-089	1	4.5V-12.0V POTENTIOMETER		
17.	274-940	1	INDICATOR		

FOOTNOTES

# TOOL BOX GAUGES

JT27M1 - AT27M1

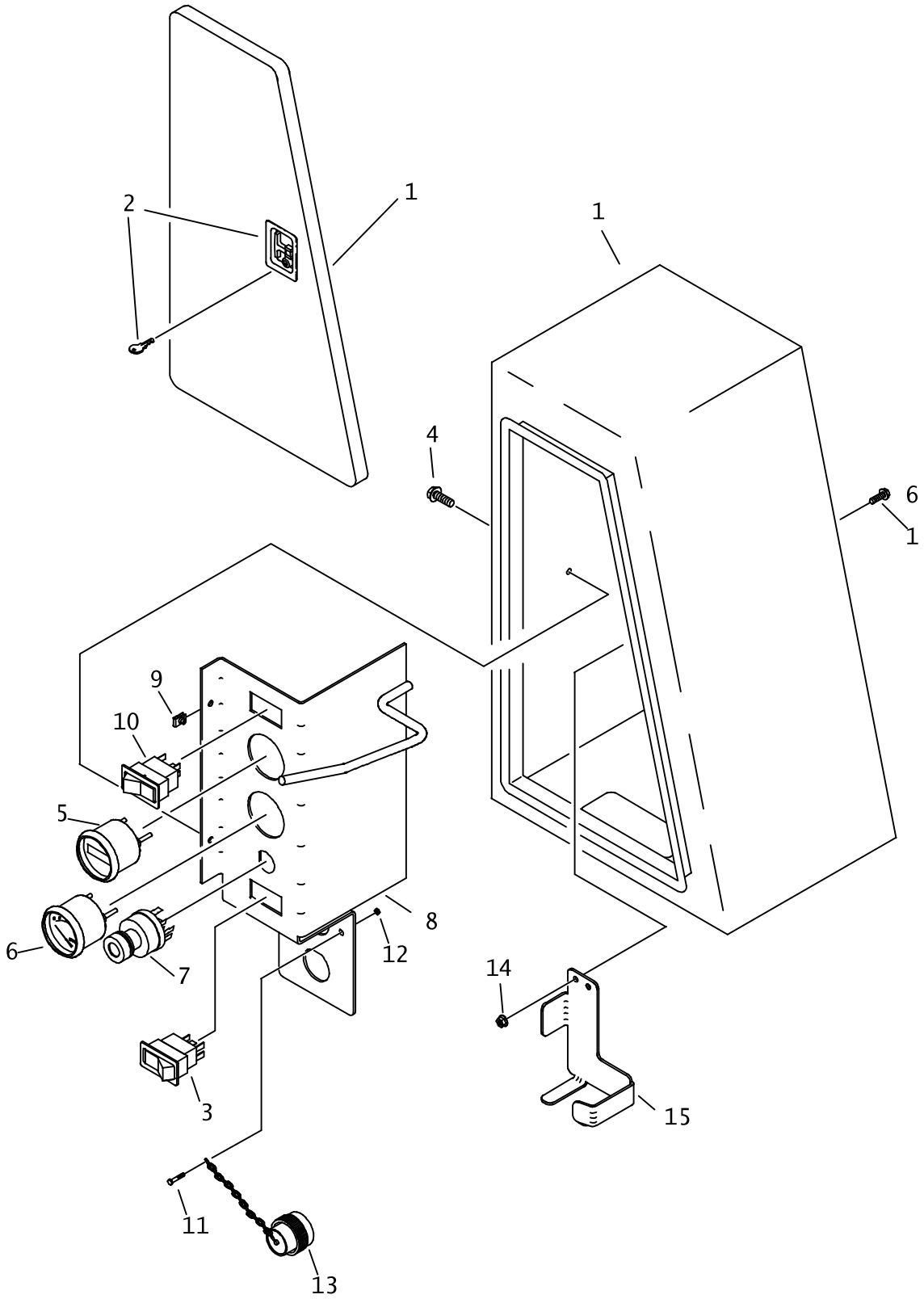

## TOOL BOX GAUGES

### JT27M1 - AT27M1

REF NO.	PART NUMBER	QTY	DESCRIPTION	REMARKS
1.	307-830	1	TOOL BOX	
2.	110-514	1	LOCKING LATCH, ADJUSTABLE	INCL KEYS
	110-596		KEYS (PAIR)	
3.	217-917	1	ROCKER SWITCH (DPDT) OFF-ON	NYOGEL 700016
4.	106-640	2	SCREW (M6-1.00 X 20MM, BUT SOC)	
5.	215-128	1	HOUR METER	
6.	215-129	1	VOLT METER	
	215-415		NITE-LIGHT KIT (12V DC)	OPTION
7.	214-852	1	IGNITION SWITCH	
	214-961		KEY, PAIR (BASE CODE)	
	214-962		SWITCH MOUNTING NUT	
8.	306-998	1	GAUGE PANEL WELDMENT	
9.	106-574	2	CLIP NUT (M6-1.00)	
10.	217-907	1	ROCKER SWITCH (DPDT) ON-ON	NYOGEL 700016
11.	107-269	1	SCREW (#4-40 X 3/4", PAN)	
12.	106-277	1	NUT (#4-40, BRASS)	
13.	214-812	1	PROTECTIVE CAP	
14.	106-385	2	FLG LOCKNUT (M6-1.00)	
15.	313-986	1	CONTROL BOX BRACKET	
16.	106-378	2	FLG LK SCREW (M6-1.00 X 12MM)	

NOT SHOWN:

FOOTNOTES:

NOTE:



# HYDRAULICS

# HYDRAULIC SCHEMATIC JT2720 MACH 1 ONLY

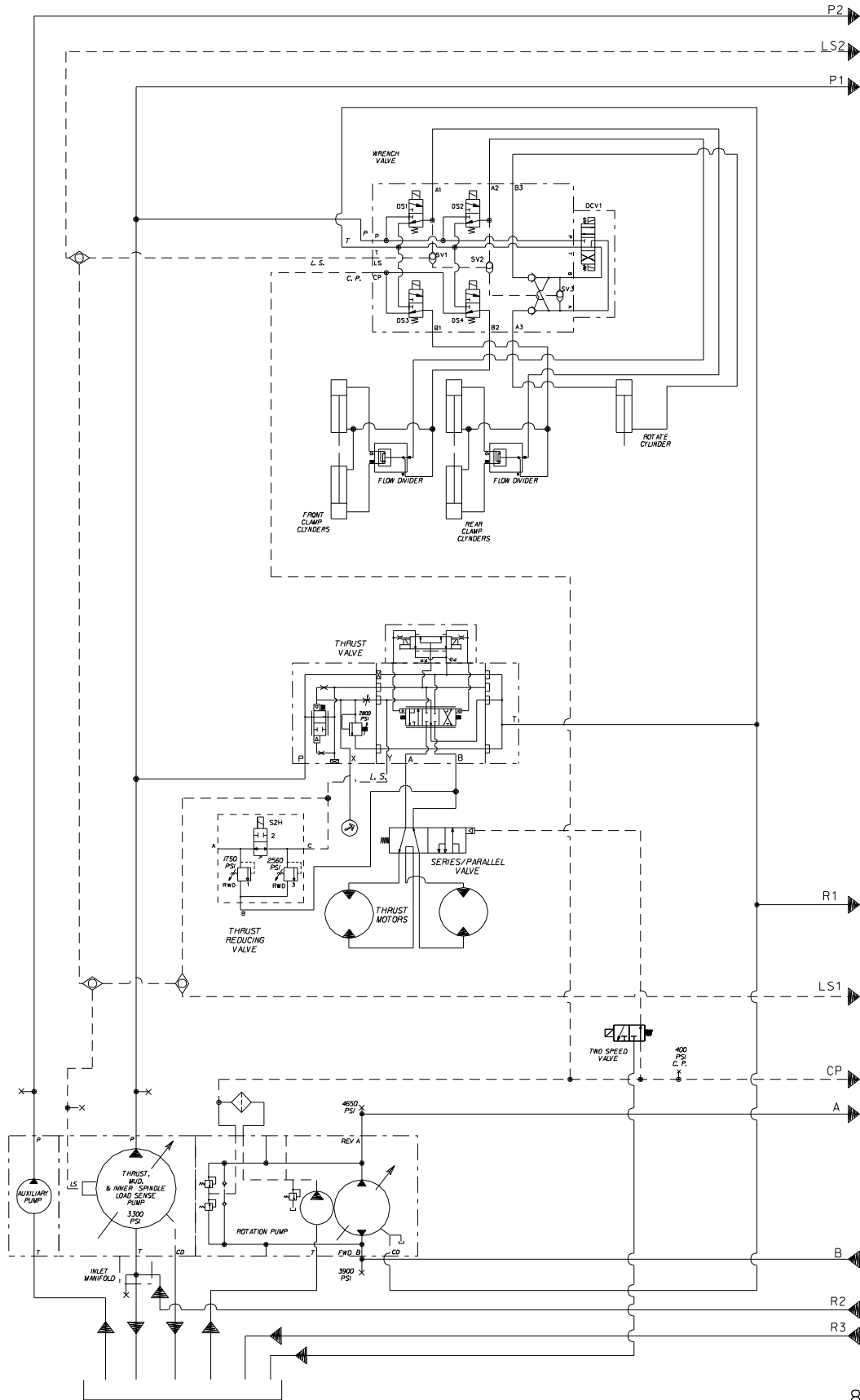

B

807-876



# HYDRAULIC SCHEMATIC

## JT2720 MACH 1 ONLY

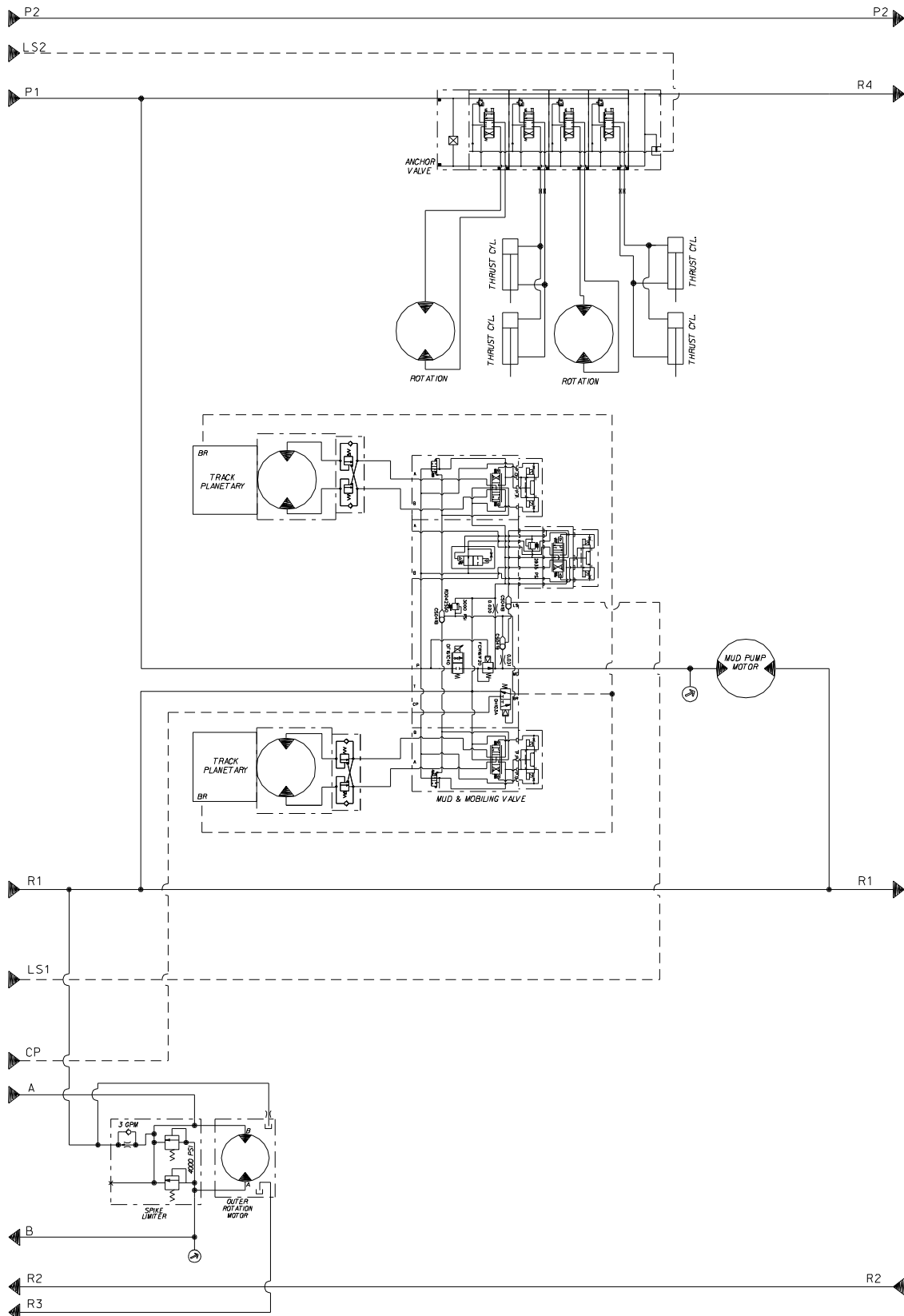

# HYDRAULIC SCHEMATIC JT2720 MACH 1 ONLY

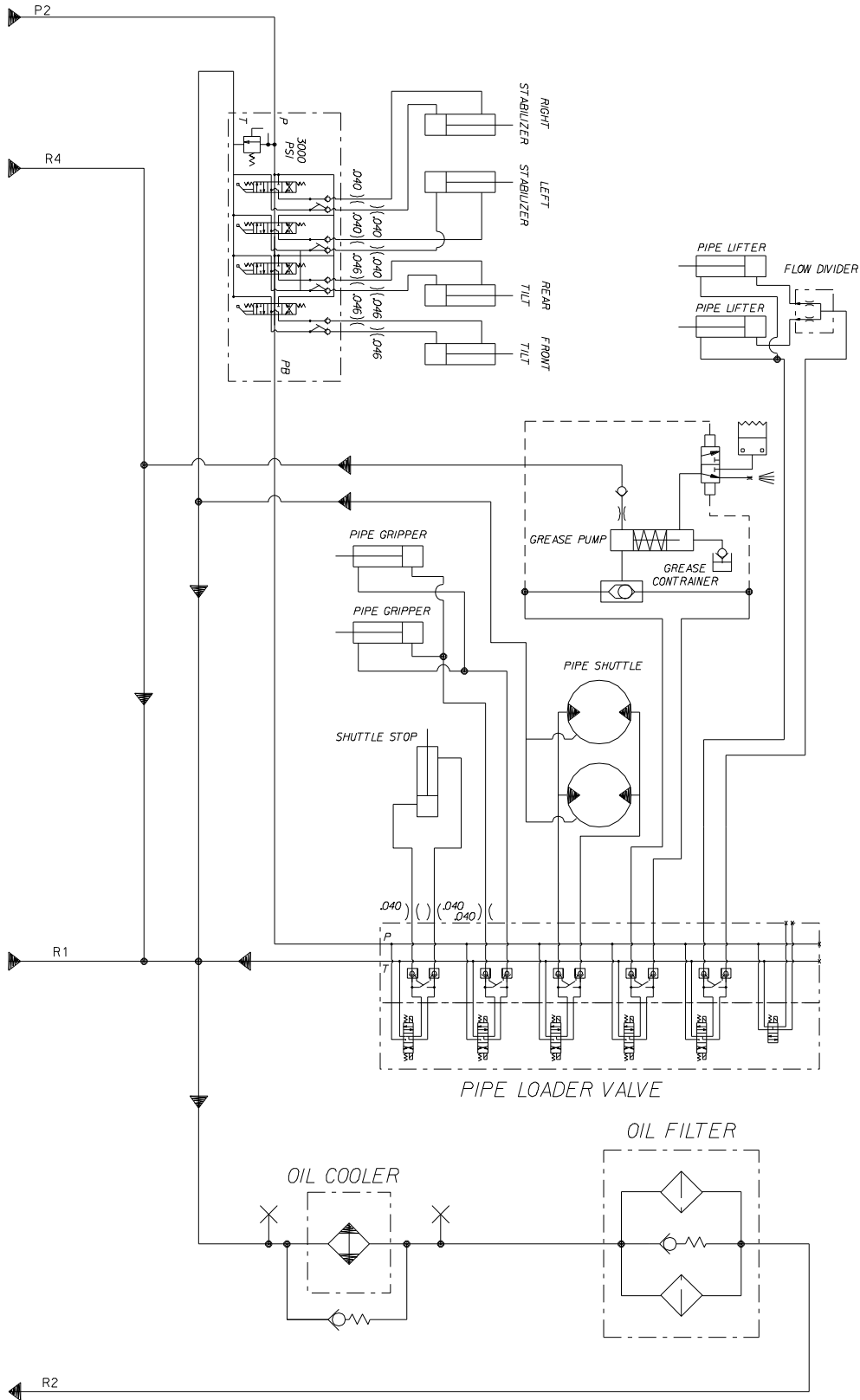



# HYDRAULIC SCHEMATIC JT2720 MACH 1 ALL TERRAIN ONLY

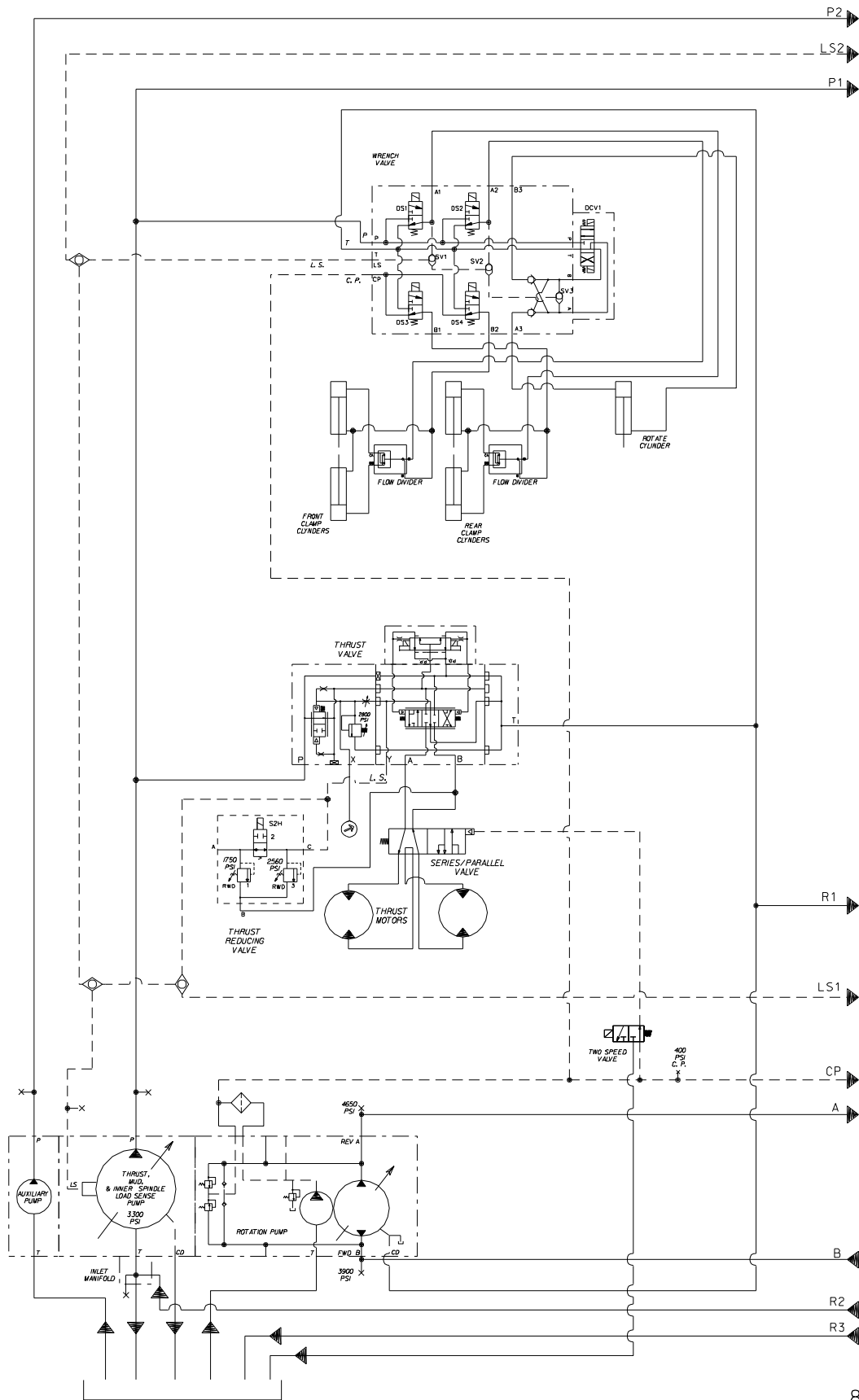

C

807-117

# HYDRAULIC SCHEMATIC JT2720 MACH 1 ALL TERRAIN ONLY

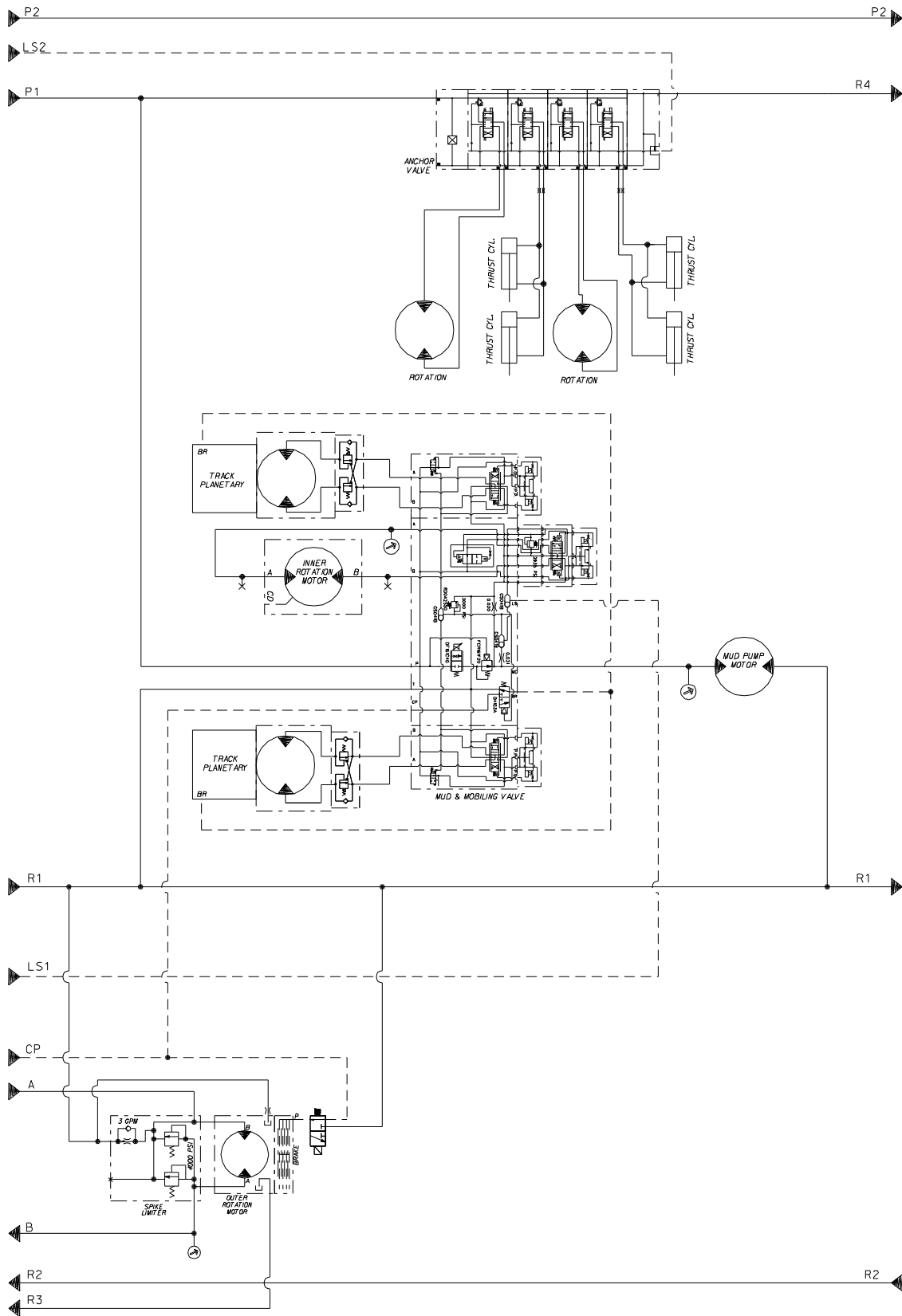

# HYDRAULIC SCHEMATIC

## JT2720 MACH 1 ALL TERRAIN ONLY

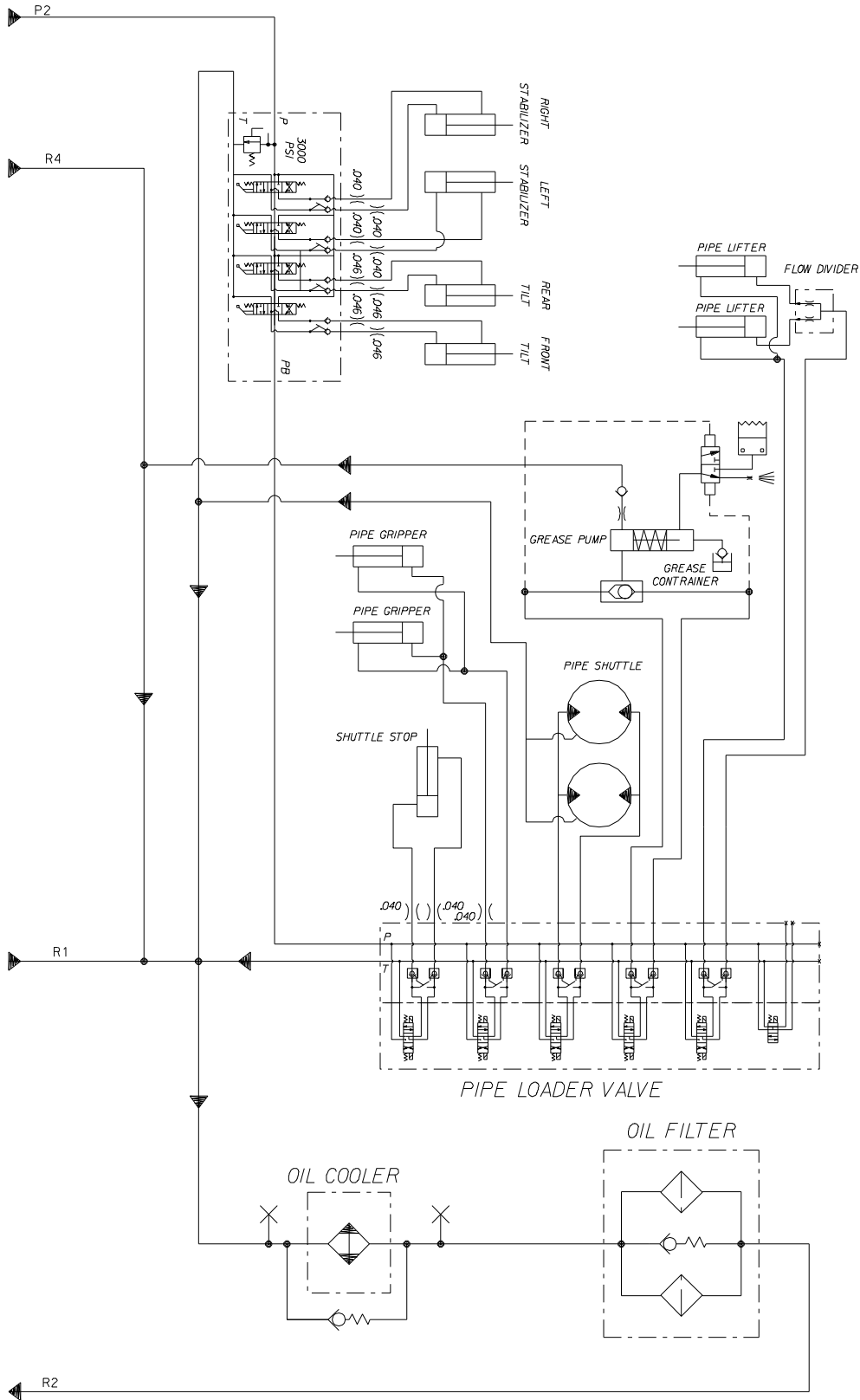



# HYDRAULIC DIAGRAM

JT2720 MACH 1 ONLY

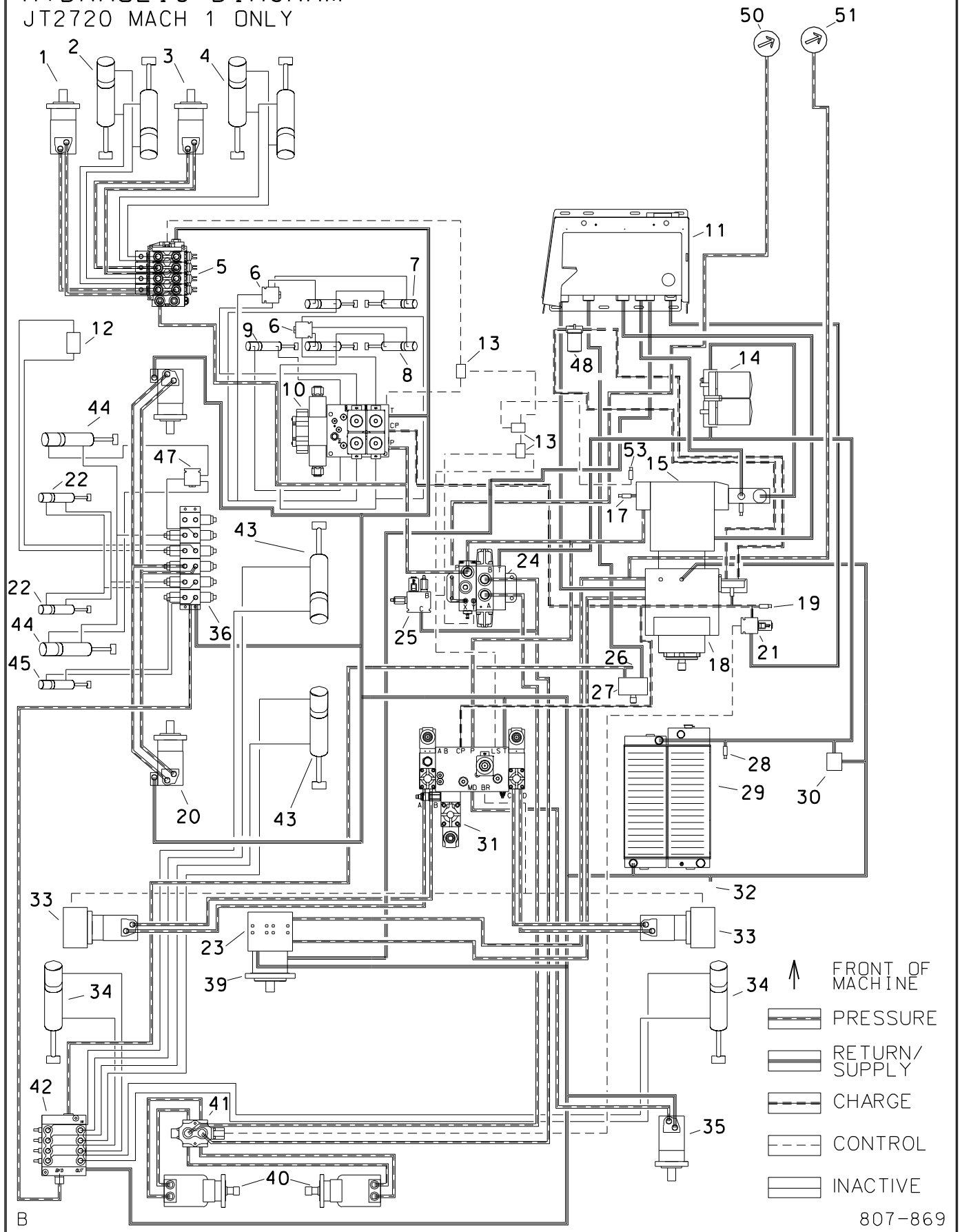

- ↑ FRONT OF MACHINE
- PRESSURE
- RETURN/SUPPLY
- - - CHARGE
- - - CONTROL
- INACTIVE





# HYDRAULIC DIAGRAM

## JT2720 MACH 1 ALL TERRAIN ONLY

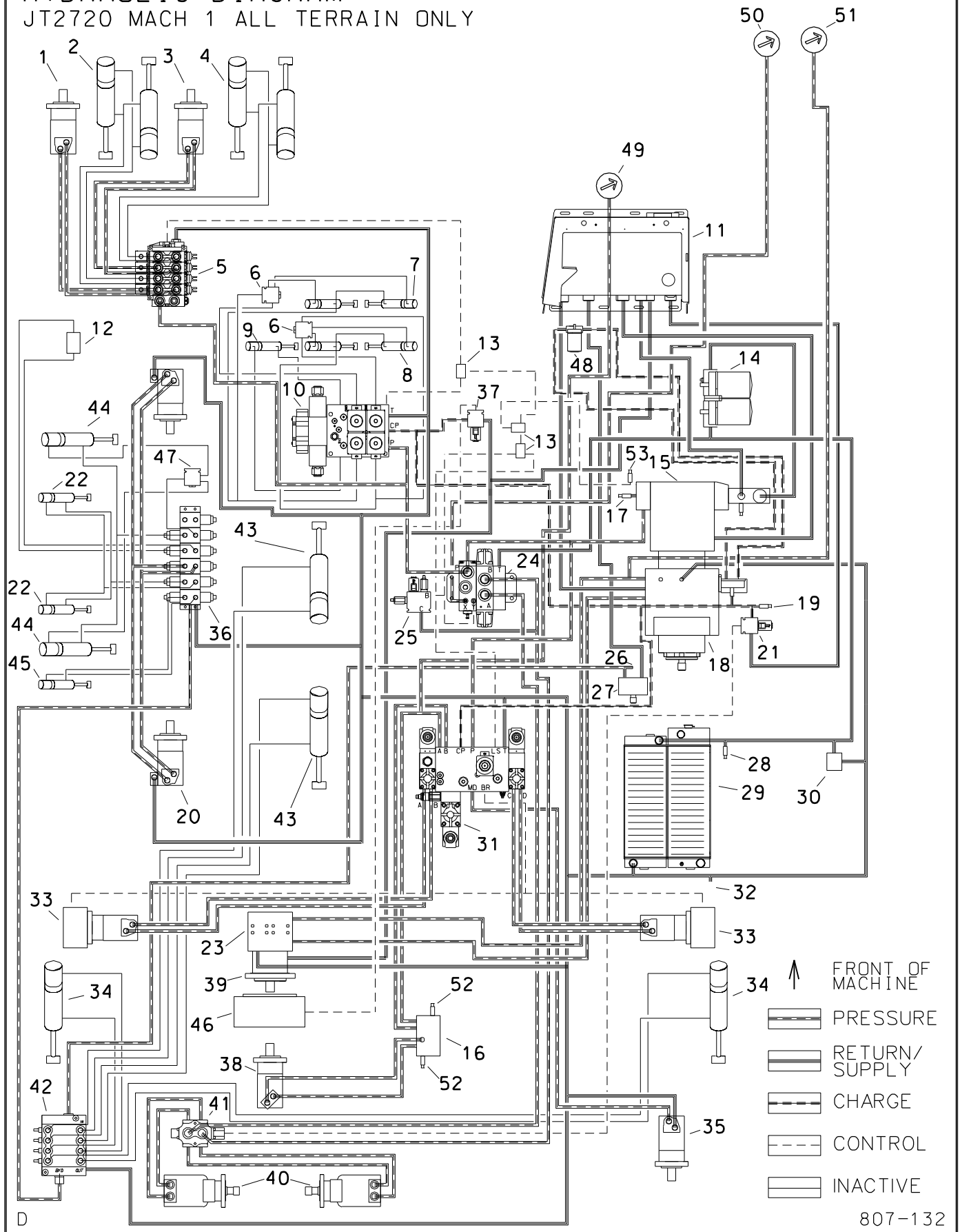

# HYDRAULIC DIAGRAM

## JT2720 MACH 1 ALL TERRAIN ONLY

REF NO.	DESCRIPTION	REMARKS
1.	LEFT ANCHOR MOTOR	
2.	LEFT ANCHOR CYLINDERS	
3.	RIGHT ANCHOR MOTOR	
4.	RIGHT ANCHOR CYLINDER	
5.	ANCHOR VALVE	
6.	FLOW DIVIDER VALVE	
7.	FRONT WRENCH CYLINDERS	
8.	REAR WRENCH CYLINDERS	
9.	WRENCH ROTATE CYLINDER	
10.	FRONT WRENCH VALVE	
11.	HYDRAULIC RESERVOIR	ELECTRICAL BRACKET REMOVED FOR CLARITY
12.	GREASER VALVE BODY	
13.	SHUTTLE VALVES	
14.	HYDRAULIC OIL FILTER	
15.	LOAD SENSE PUMP	
16.	INNER ROTATION MANIFOLD	
17.	LOAD SENSE PRESSURE TEST PORT	
18.	ROTATION PUMP	
19.	CHARGE PRESSURE TEST PORT	
20.	PIPE LOADER SHUTTLE MOTOR	ROTATED 180° FOR CLARITY OF PORTS
21.	TWO SPEED VALVE	
22.	PIPE GRIPPER CYLINDERS	
23.	SPIKE LIMITER BLOCK	
24.	THRUST VALVE	
25.	THRUST LIMITER VALVE	
26.	AUXILIARY PRESSURE TEST TEE	
27.	AUXILIARY PUMP	
28.	OIL COOLER OUTLET TEST PORT	
29.	OIL COOLER	
30.	OIL COOLER BYPASS	
31.	GROUND DRIVE AND MUD VALVE	
32.	OIL COOLER INLET TEST PORT	
33.	GROUND DRIVE MOTORS W/ COUNTER BALANCE VALVES	
34.	STABILIZER CYLINDERS	
35.	DRILLING FLUID MOTOR	
36.	PIPE HANDLING VALVE	
37.	BRAKE SOLENOID	
38.	INNER ROTATION MOTOR	
39.	OUTER ROTATION MOTOR	
40.	THRUST MOTOR	
41.	SERIES PARALLEL VALVE	ROTATED 90° FOR CLARITY OF PORTS
42.	SET-UP VALVE	
43.	DRILL FRAME PIVOT CYLINDER	
44.	PIPE LIFT CYLINDER	
45.	SHUTTLE STOP CYLINDER	
46.	OUTER ROT. BRAKE	
47.	FLOW DIVIDER VALVE	
48.	CHARGE FILTER	
49.	INNER ROTATION PRESSURE GUAGE	
50.	THRUST PRESSURE GUAGE	
51.	OUTER ROTATION PRESSURE GUAGE	
52.	INNER ROTATION TEST PORTS	
53.	LOAD SENSE SIGNAL PRESSURE TEST PORT	

# HYDRAULIC PUMPS

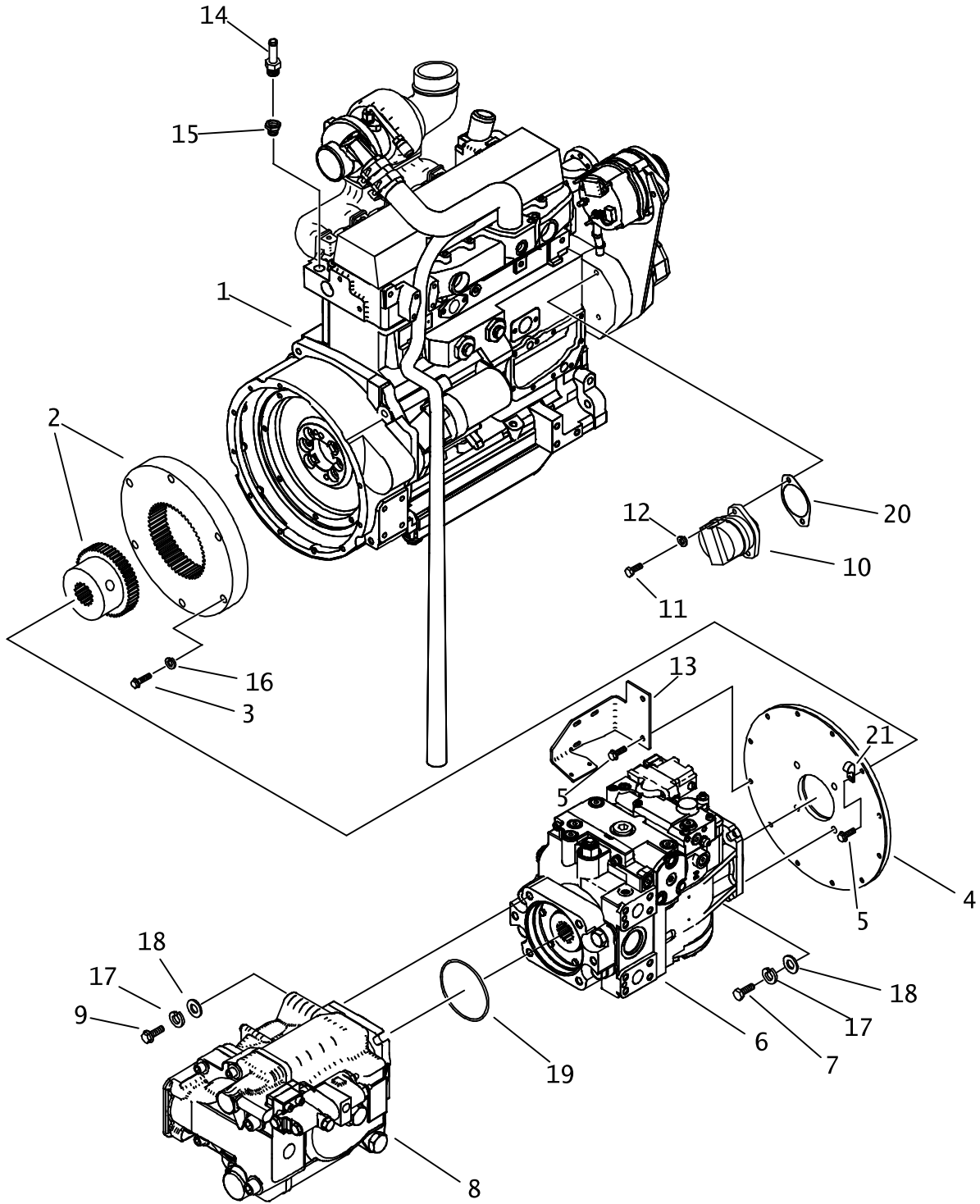

## HYDRAULIC PUMPS

REF NO.	PART NUMBER	QTY	DESCRIPTION	REMARKS
1.	194-020	-	ENGINE - JOHN DEERE DIESEL	OBSOLETE
2.	160-914	1	FLYWHEEL COUPLING	
	105-918	-	BOLT (7/16-NC X 1-1/2", SOC)	SEE FOOTNOTE 1
3.	105-156	8	BOLT (3/8-NC X 1-1/2")	SEE FOOTNOTE 1    LOCTITE 277
4.	160-901	1	PUMP PLATE	
5.	106-164	12	FLG LK SCREW (M10-1.50 X 30mm)	
6.	153-105	1	HYD PUMP	
	197-099	-	REBUILT 153-105 HYD. PUMP	
	499-061		CHARGE PUMP - 26CC	
	499-062		PUMP SHAFT (13T)	
	500-764		MULTIFUNCTION VALVE - LIMITER	
	190-764		SEAL REPAIR KIT	
	149-544		EDC CONTROLLER	
7.	106-333	4	SCREW (M12-1.75 X 40mm)	
8.	149-390	1	HYDRAULIC PUMP	INCLUDES REF 19
	197-100	-	REBUILT 149-390 HYD. PUMP	
	190-803		SEAL REPAIR KIT	
	190-804		BEARING KIT	
	499-063		SHAFT (SPLINED 14T)	
	499-064		LOAD SENSE CONTROL	
9.	105-048	4	BOLT (1/2-NC X 1-1/2")	
10.	158-461	1	HYD PUMP	
	500-966		SEAL REPAIR KIT	
11.	106-081	2	SCREW (M10-1.50 X 35MM, 12.9)	
12.	106-090	2	LOCK WASHER (M10)	
13.	307-400	1	BRACKET, HYD. MOUNTING	
14.	155-162	1	COUPLER (04N-5/16OD, STR)	
15.	115-286	1	PIPE BUSHING (1/2NMX1/4NF)	
16.	105-072	8	LOCK WASHER (3/8")	
17.	105-070	8	LOCK WASHER (1/2")	
18.	105-244	8	WASHER (1/2")	
19.	157-183	1	O-RING (048 D70)	
20.	168-619	1	PUMP GASKET	
21.	110-333	1	BOLT-ON CLAMP (1")	

NOT SHOWN:

FOOTNOTES:

- TORQUE BOLT PER TORQUE CHART IN BACK OF MANUAL

NOTE:

# PUMP INLET

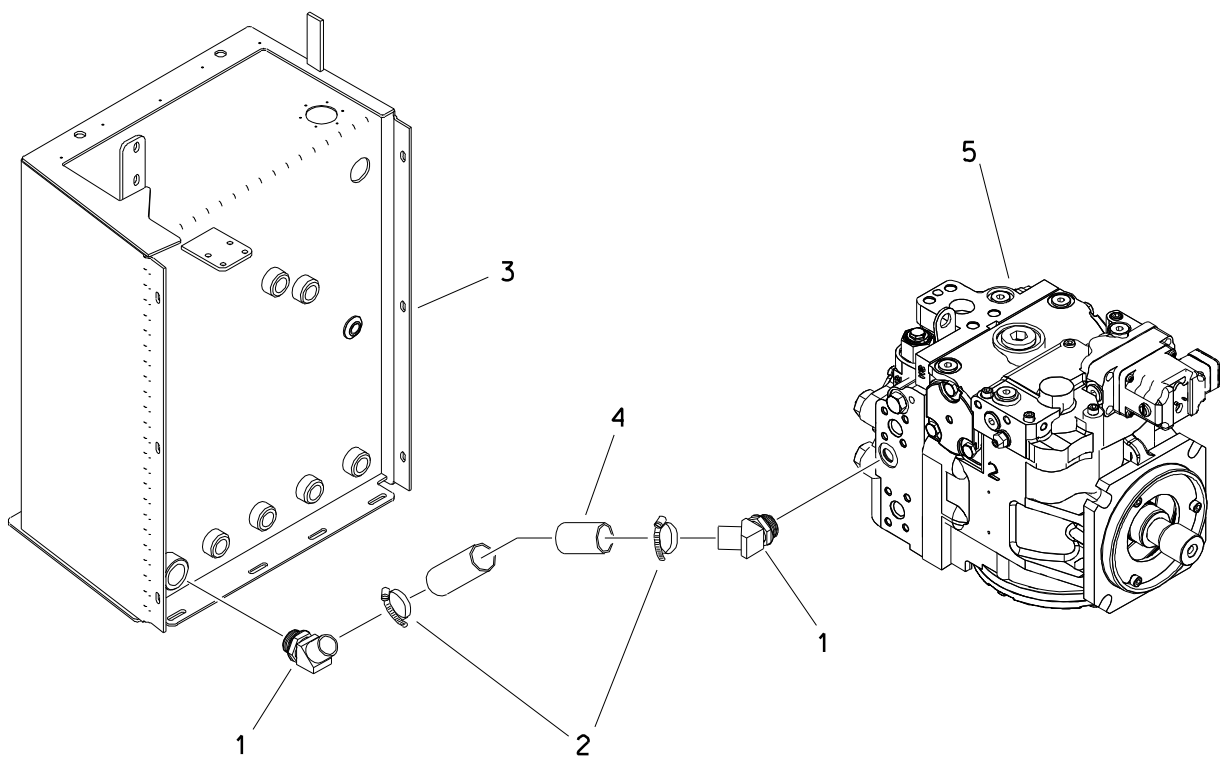

# PUMP INLET

REF NO.	PART NUMBER	QTY	DESCRIPTION	REMARKS
1.	514-226	2	S/O COUPLER (20S-24H45)	
2.	111-028	2	T-BOLT CLAMP (1.75"-2.00")	
3.	149-468	-	HYDRAULIC TANK WELDMENT	
4.	116-588	AR	BULK HOSE (1-1/2",SOLD PER 1')	USE 1 @ 18.5"
5.	153-105	-	HYDRAULIC PUMP	

FOOTNOTES

# HYDRAULIC RESERVOIR

ENDS WITH S/N  
BEGINS WITH S/N

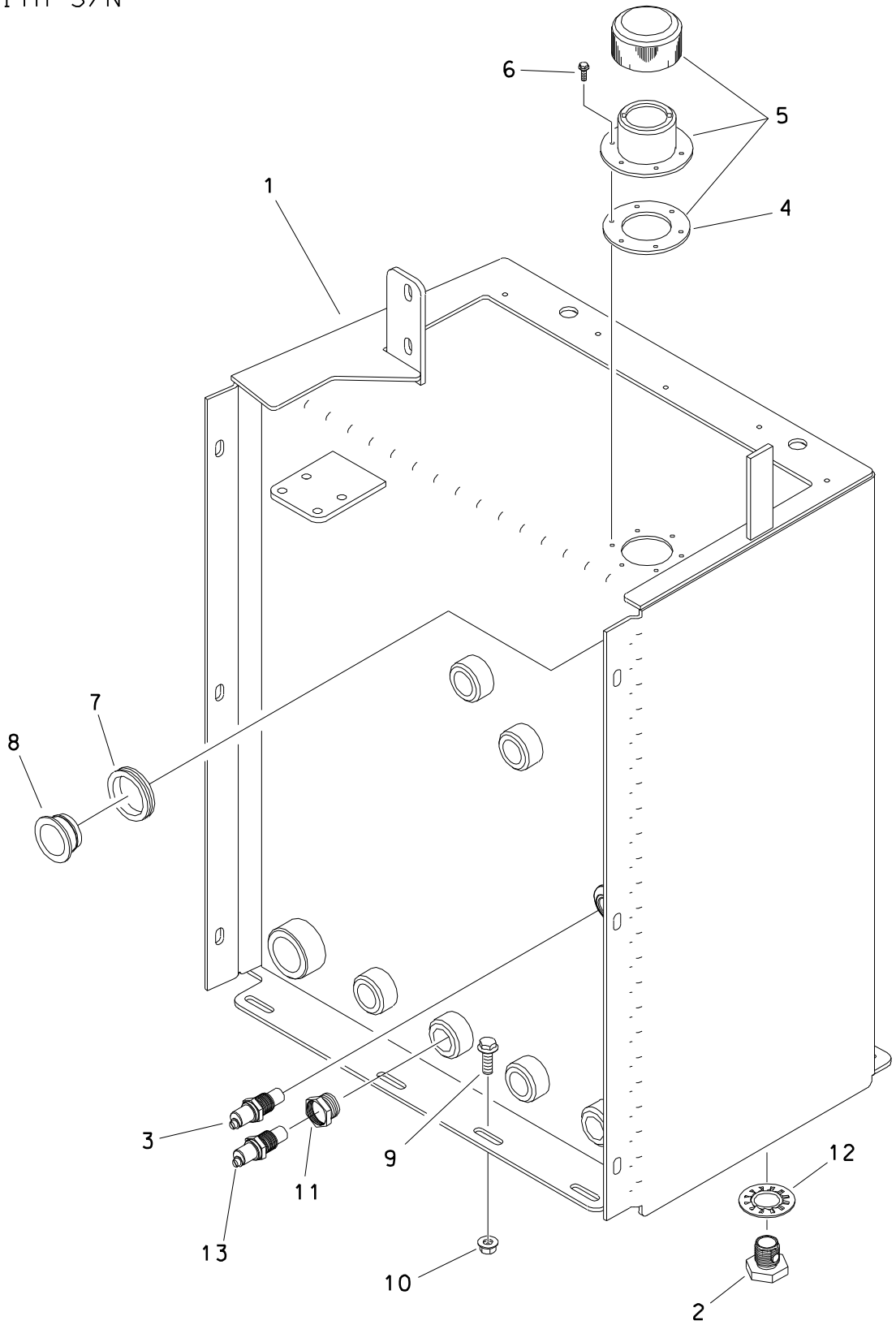



HYDRAULIC RESERVOIR  
 ENDS WITH S/N  
 BEGINS WITH S/N

REF NO.	PART NUMBER	QTY	DESCRIPTION	REMARKS
1.	149-468	1	HYDRAULIC RESERVOIR	
2.	149-398	1	DRAIN PLUG (1" W/.375 ORF)	
3.	<del>215-148</del> 214-819	1	TEMPERATURE SWITCH	
4.	165-626	1	FILLER NECK GASKET	
5.	110-008	1	FILLER BREATHER (2-1/8")	INCL REF NO.4
6.	105-214	6	FLG SCREW (#10-24 X 1/2")	
7.	115-320	1	GROMMET (1-1/2")	
8.	116-218 360-849	1	SIGHT GLASS (2") REFLECTOR	INCL REFLECTOR
9.	106-724	8	FLG SCREW (M10-1.50 X 25mm)	
10.	105-894	8	LOCKNUT(M10-1.50,PRV TRQ,10.9)	
11.	159-392	1	PLUG (12S, SOC.	ENDS WITH S/N
	155-175	1	BUSHING (1-1/16 - SAE X 1 / 2 NP	BEGINS WITH S/N
12.	149-829	1	1" SEAL WASHER	
13.	214-842	1	TEMPERATURE SWITCH (N.O. 185°)	BEGINS WITH S/N

FOOTNOTES

# COOLER HYDRAULICS

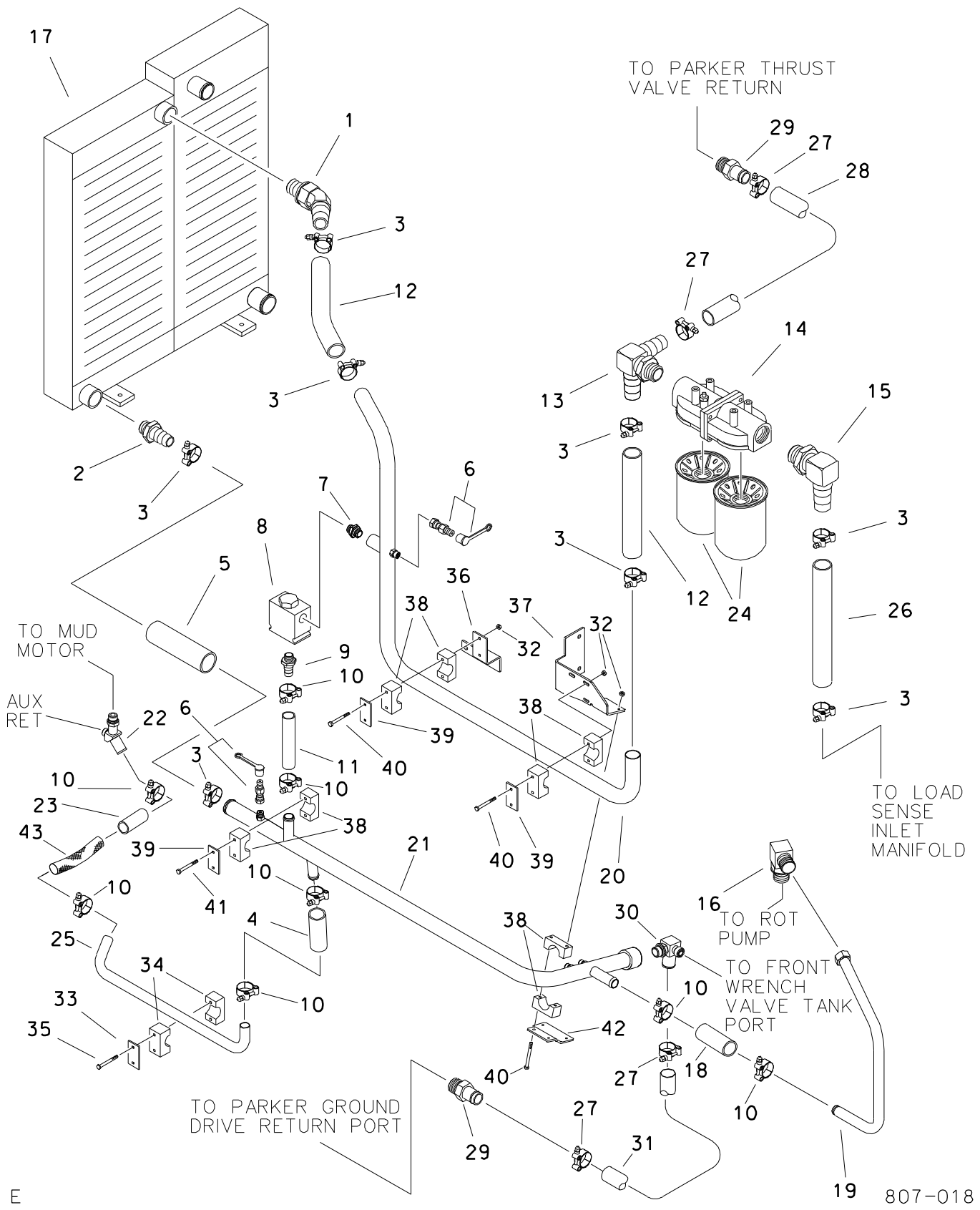

E

807-018

## COOLER HYDRAULICS

REF NO.	PART NUMBER	QTY	DESCRIPTION	REMARKS
1.	514-226	1	S/O COUPLER (20S-24H45)	
2.	155-148	1	S/O COUPLER (20S-24H)	
3.	111-028	8	T-BOLT CLAMP (1.75"-2.00")	
4.	116-460	AR	BULK HOSE (1", SOLD PER 1')	USE 1 @ 4.5"
5.	116-588	AR	BULK HOSE (1-1/2" SOLD PER 1')	USE 1 @ 5.75"
6.	159-157	2	QDC ADAPTER (O2-O6OF)	
	159-148	2	DUST CAP (1/8")	
7.	155-152	1	CONNECTOR (12S-12S)	
8.	159-253	1	FLOW CHECK VALVE	
	500-820		SEAL REPAIR KIT	
9.	155-161	1	S/O COUPLER (12S-16H)	
10.	111-027	9	WORM CLAMP (3/4" TO 1-1/2")	
11.	116-460	AR	BULK HOSE (1", SOLD PER 1')	USE 1 @ 13"
12.	116-588	AR	BULK HOSE (1-1/2", SOLD PER 1')	USE 2 @ 12"
13.	149-506	1	TEE (24S-20H-24H, SPECIAL)	
14.	159-411	1	FILTER HEAD (20SF-20SF)	
	168-616	1	FILTER HEAD GASKET	
15.	514-135	1	S/O COUPLER (24S-24H90)	
16.	154-377	1	CONNECTOR (12S-16090)	
17.	194-245	1	RADIATOR	
18.	116-460	AR	BULK HOSE (1" SOLD PER 1')	USE 1 @ 5.5"
19.	156-918	1	ROTATION CASE DRAIN	
20.	149-600	1	COOLER OUTLET LINE	
21.	156-905	1	HYD LINE (24)	
22.	149-511	1	TEE (10S-080-16H), SPECIAL	
23.	116-460	AR	BULK HOSE (1", SOLD PER 1')	USE 1 @ 30"
24.	159-079	2	FILTER ELEMENT (1-1/2-UNF)	SEE FOOTNOTE 1
	149-840		FILTER ELEMENT (1-1/2-UNF)	SEE FOOTNOTE 1
25.	149-510	1	MUD RETURN LINE	
26.	116-588	AR	BULK HOSE (1-1/2", SOLD PER 1')	USE 1 @ 14.75"
27.	149-342	4	T-BOLT CLAMP (1.687"-1.50")	
28.	116-587	AR	BULK HOSE (1-1/4", SOLD PER 1')	USE 1 @ 25"
29.	155-047	2	S/O COUPLER (16S-20H)	
30.	149-507	1	TEE (12S-100-20H, SPECIAL)	
31.	116-587	AR	BULK HOSE (1-1/4", SOLD PER 1')	USE 1 @ 31"
32.	105-085	8	LOCKNUT (1/4-NC)	
33.	322-289	1	BACKUP (BOLT-ON)	
34.	110-573	1	BOLT-ON CLAMP (1", PER SET)	
35.	105-818	2	BOLT (1/4-NC X 1-1/2")	
36.	363-677	1	BRACKET	
37.	307-400	1	BRACKET, HYD. MOUNTING	
38.	111-008	4	BLT-ON CLP (1.5", SOLD PER SET)	
39.	322-362	3	BACKUP SPACER	
40.	107-283	6	BOLT (1/4-NC X 3")	
41.	105-224	2	BOLT (1/4-NC X 2-1/2")	
42.	305-931	1	PLATE, VALVE MOUNT	
43.	117-678	1	ABRASION SLEEVE (1.75" X 29")	

## FOOTNOTES

1. FILTER 149-840 IS FOR BREAK IN ONLY, USE FILTER 159-079 FOR NORMAL REPLACEMENT

## NOTE:

REFER TO O-RING CHART (800-301) IN BACK OF THE BOOK FOR REPLACEMENT OF O-RINGS.

# CHARGE FILTER & SERIES PARALLEL SHIFTING SOLENOID

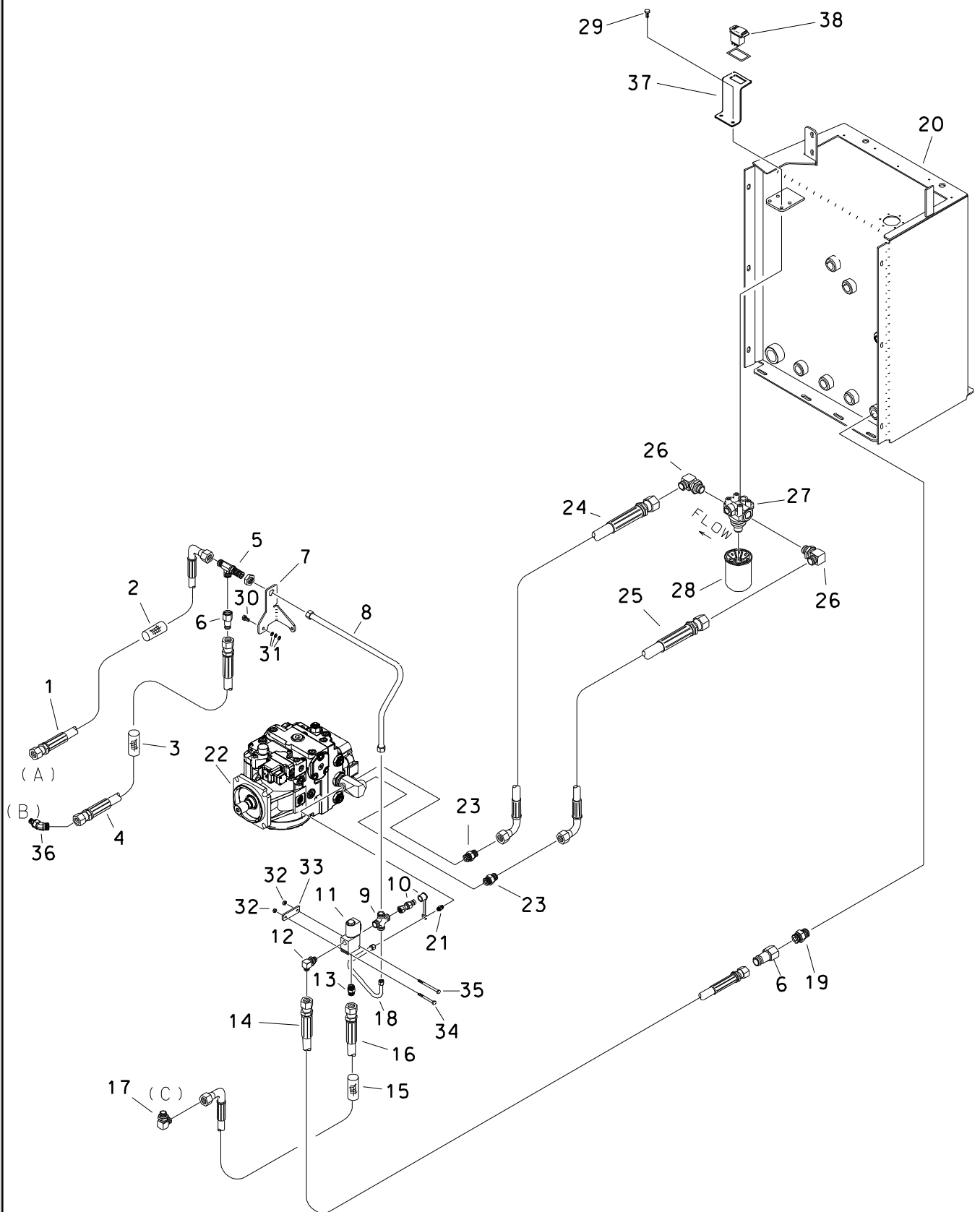

## CHARGE FILTER &amp; SERIES PARALLEL SHIFTING SOLENOID

REF NO.	PART NUMBER	QTY	DESCRIPTION	REMARKS
1.	515-357	1	HOSE (0800F90L-50"-3000)	
2.	117-395	1	ABRASION SLEEVE (1.25" X 50")	
3.	117-416	1	ABRASION SLEEVE (1.00" X 50")	
4.	153-304	1	HOSE (060FX-50"-3000)	
5.	154-295	1	BK RUN TEE (080-080-080BK)	
6.	154-262	2	REDUCER (060-080F)	
7.	305-933	1	BULKHEAD BRACKET	
8.	149-526	1	HYDRAULIC LINE (-08)	
9.	149-847	1	SPECIAL CROSS 06S-060-060-080	
10.	159-157	1	QDC ADAPTER (02-060F)	
11.	158-627	1	SOLENOID VALVE	
12.	154-342	1	CONNECTOR (06S-06090)	
13.	154-250	1	CONNECTOR (040-06S45)	
14.	154-722	1	HOSE (060FX-32"-3000)	
15.	117-759	1	ABRASION SLEEVE (1.00" X 160")	
16.	515-522	1	HOSE (040FX90-169"-3000)	
17.	154-252	1	CONNECTOR (04S-04090)	
18.	149-527	1	HYDRAULIC LINE (-06)	
19.	154-234	1	CONNECTOR (080-12S)	
20.	149-468	1	HYDRAULIC TANK WELDMENT	
21.	154-221	1	CONNECTOR (06S-060)	
22.	153-105	-	HYDRAULIC PUMP	
23.	154-301	2	CONNECTOR (10S-100)	
24.	153-267	1	SPECIAL HOSE 100FX90S-28"-1500	
25.	153-268	1	SPECIAL HOSE 100FX90S-24"-1500	
26.	154-300	2	CONNECTOR (100-12S90)	
27.	153-050	1	FILTER HEAD (-12 SAE PORTS)	
28.	149-939	1	FILTER	
29.	105-823	4	FLG LK BOLT (5/16-NC X 3/4")	
30.	105-806	1	SCREW (M8-1.25 X 25MM)	TORQUE TO 24 FT/LBS
31.	106-389	3	WASHER (M8)	
32.	105-085	2	LOCKNUT (1/4-NC)	
33.	343-342	1	FLOW DIVIDER BRACKET	
34.	105-224	1	BOLT (1/4-NC X 2-1/2")	
35.	106-064	1	BOLT (1/4-NC X 4-1/2")	
36.	154-224	1	CONNECTOR (06S-06045)	
37.	315-996	1	ROCKER SWITCH BRACKET	
38.	217-907	1	ROCKER SWITCH (DPDT)	

## FOOTNOTES

1. (A) CONNECTS TO CHARGE PRESSURE HARDLINE ON DRILL FRAME
2. (B) CONNECTS TO PARKER GROUND DRIVE MOBILE VALVE "CP"
3. (C) CONNECTS TO SERIES PARALLEL VALVE

## NOTE

REFER TO O-RING CHART (800-301) IN BACK OF THE BOOK FOR REPLACEMENT OF O-RINGS.

# AUXILARY PUMP INLET HYDRAULICS

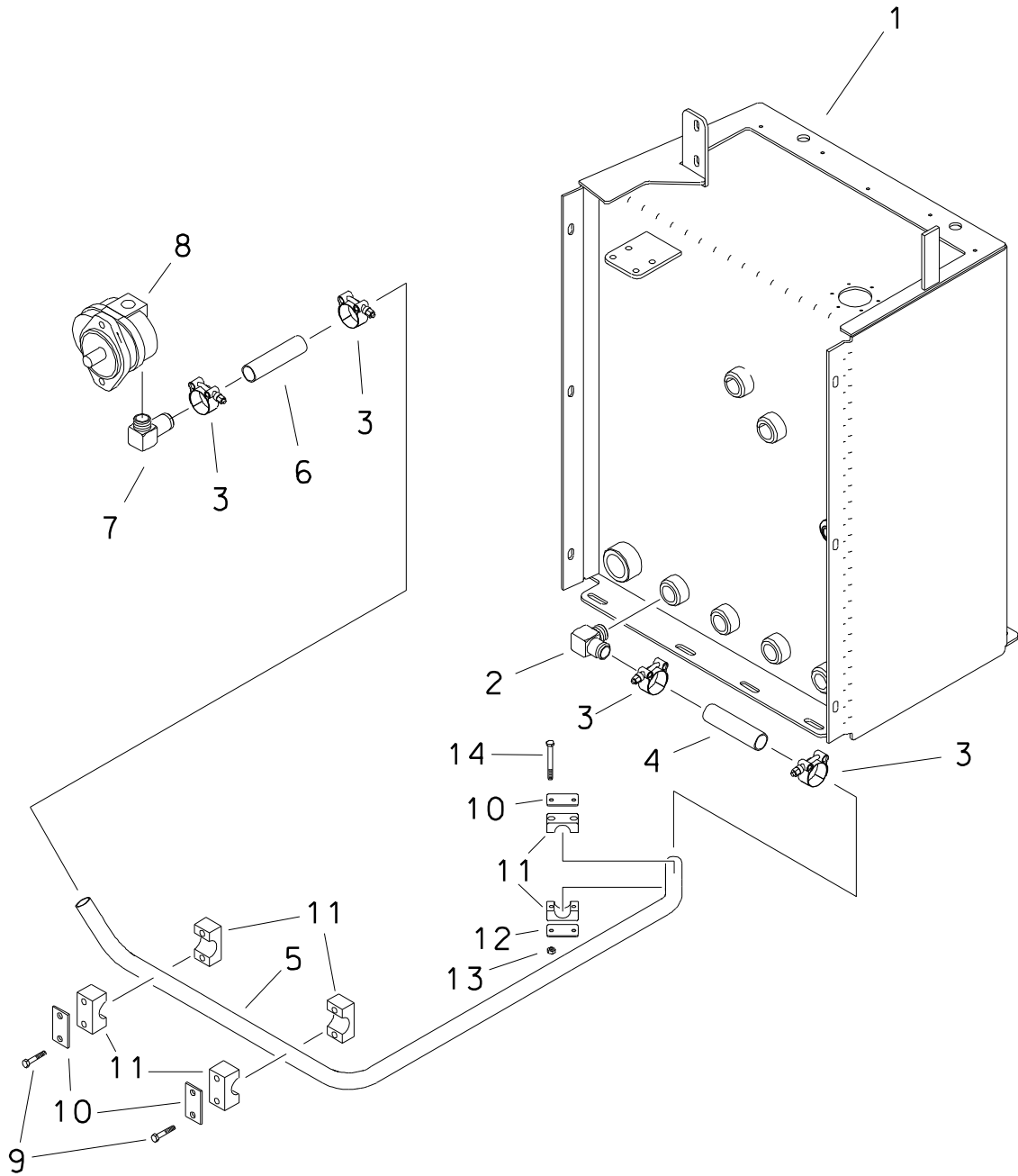

# AUXILARY PUMP INLET HYDRAULICS

REF NO.	PART NUMBER	QTY	DESCRIPTION	REMARKS
1.	149-468	1	HYDRAULIC TANK WELDMENT	
2.	155-146	1	S/O COUPLER (12S-16H90)	
3.	111-027	4	T-BOLT CLAMP (1.25"-1.50")	
4.	116-460	AR	BULK HOSE (1", SOLD PER 1')	USE 1 @ 13.5"
5.	149-535	1	HYDRAULIC LINE (-16)	
6.	116-460	AR	BULK HOSE (1", SOLD PER 1')	USE 1 @ 22.5"
7.	154-188	1	S/O COUPLER (16S-16H90)	
8.	158-461	1	HYDRAULIC PUMP	
	500-966	-	SEAL REPAIR KIT	
9.	105-818	4	BOLT (1/4-NC X 1-1/2")	
10.	322-289	3	BACKUP (BOLT-ON)	
11.	110-573	3	BOLT-ON CLAMP (1", SOLD PER SET)	
12.	366-001	1	SPACER PLATE	
13.	105-085	2	LOCKNUT (1/4-NC)	
14.	105-224	2	BOLT (1/4-NC X 2-1/2")	

FOOTNOTES

NOTE  
REFER TO O-RING CHART (800-301) IN BACK OF THE BOOK FOR REPLACEMENT OF O-RINGS

# AUXILIARY PRESSURE HYDRAULICS

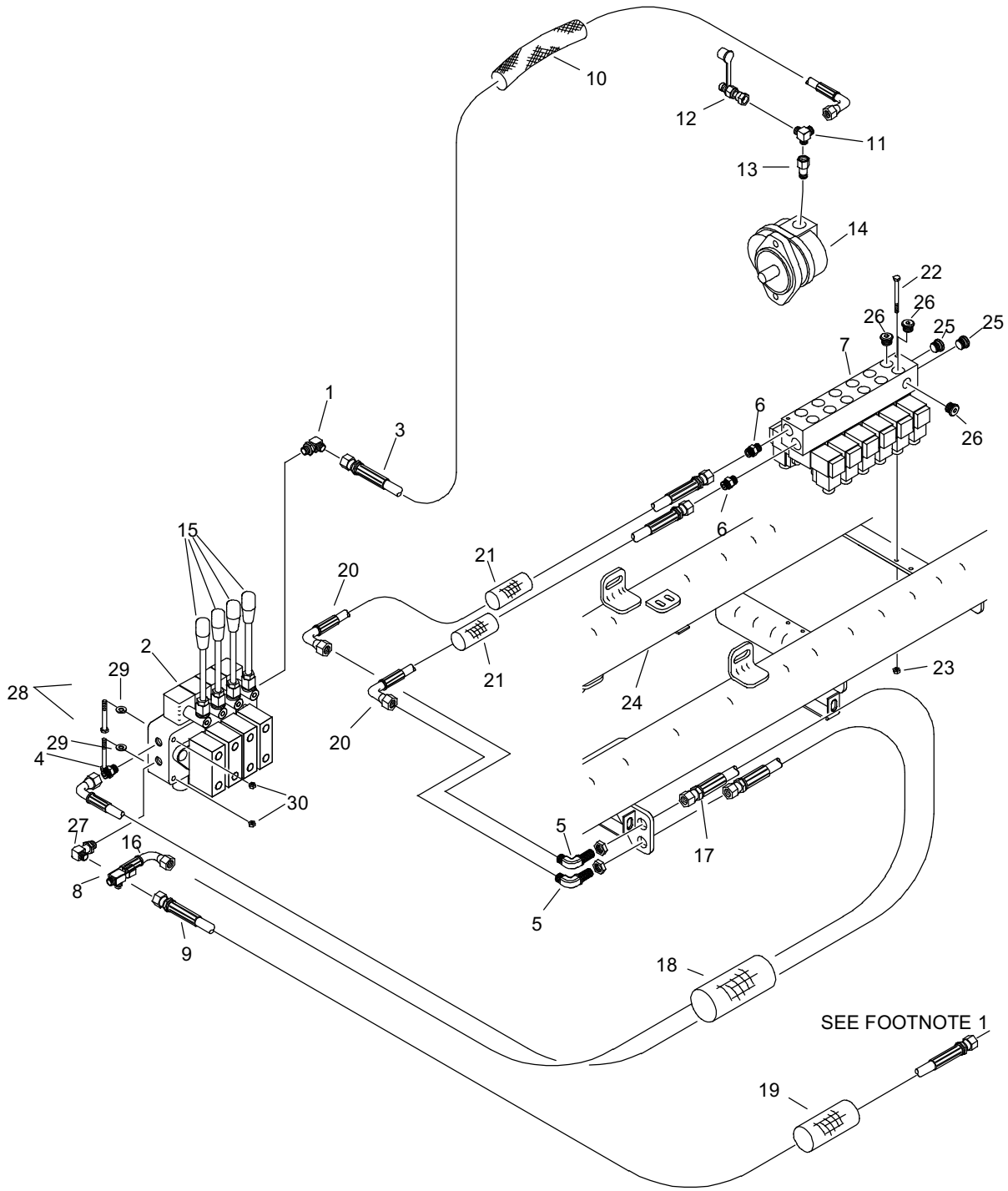

SEE FOOTNOTE 1



## AUXILIARY PRESSURE HYDRAULICS

REF NO.	PART NUMBER	QTY	DESCRIPTION	REMARKS
1.	154-235	1	CONNECTOR (08S-08090)	
2.	149-077	1	HYD CONTROL VALVE (4-SPOOL)	
3.	515-356	1	HOSE (080FX90-128"-3000)	
4.	154-233	1	CONNECTOR (08S-080)	
5.	154-396	2	BK CONNECTOR (080-08090BK)	
6.	154-246	2	CONNECTOR (06S-080)	
7.	153-741	1	HYD VALVE	
	153-095	1	HYD VALVE	OBSOLETE
	191-152	-	COIL KIT	
	191-164	-	BOLT KIT (LONG)	USE WITH 499-307
	191-165	-	BOLT KIT (SHORT)	USE WITH 499-306
	499-305	-	SOLENOID COIL	
	499-306	-	DIRECTIONAL CONTROL SOLENOID	FOR "DUMP" SECTION
	499-307	-	DIRECTIONAL CONTROL SOLENOID	FOR "WORK" SECTIONS
	499-308	-	P.O. CHECK VALVE	
8.	154-266	1	UN RUN TEE (080FX-080-080)	
9.	153-303	1	HOSE (080FX-65"-3000)	
10.	117-281	1	ABRASION SLEEVE (1.25" X 122")	
11.	514-160	1	BRANCH TEE (08S-080-040)	
12.	159-156	1	QDC ADAPTER (02-040F)	
	159-148		DUST CAP (1/8")	
13.	155-193	1	REDUCER (10S-08SF)	
14.	158-461	-	HYD PUMP	
15.	365-426	4	LEVER (M8-1.25 X 200MM)	
16.	153-301	1	HOSE (080FX90S-108"-3000)	
17.	515-741	1	HOSE (080FX90S-112"-3000)	
18.	117-197	1	ABRASION SLEEVE (2.07" X 90")	
19.	117-391	1	ABRASION SLEEVE (1.25" X 66")	
20.	515-438	2	HOSE (080FX90L-23"-3000)	
21.	117-394	2	ABRASION SLEEVE (1.25" X 23")	
22.	106-972	2	SCREW (M6-1.00 X 65MM)	
23.	106-237	2	LOCKNUT (M6-1.00, PRV TRQ, NLK)	
24.	303-783	-	PIPE LOADER WELDMENT	
25.	154-384	2	PLUG (06S)	
26.	154-383	3	PLUG (04S)	
27.	154-254	1	CONNECTOR (08S-08090, XL)	
28.	106-330	3	SCREW (M8-1.25 X 70MM)	
29.	105-117	3	WASHER (5/16")	
30.	106-561	3	LOCKNUT (M8-1.25, PRV TRQ, 10.9)	

NOT SHOWN:

FOOTNOTES:

1. CONNECTS RETURN HOSE TO 08 ORS SPUD ON MUD MOTOR RETURN FITTING.

NOTE:

REFER TO O-RING CHART (800-301) ON BACK OF THE BOOK FOR REPLACEMENT OF O-RINGS.

# THRUST PRESSURE GAUGE

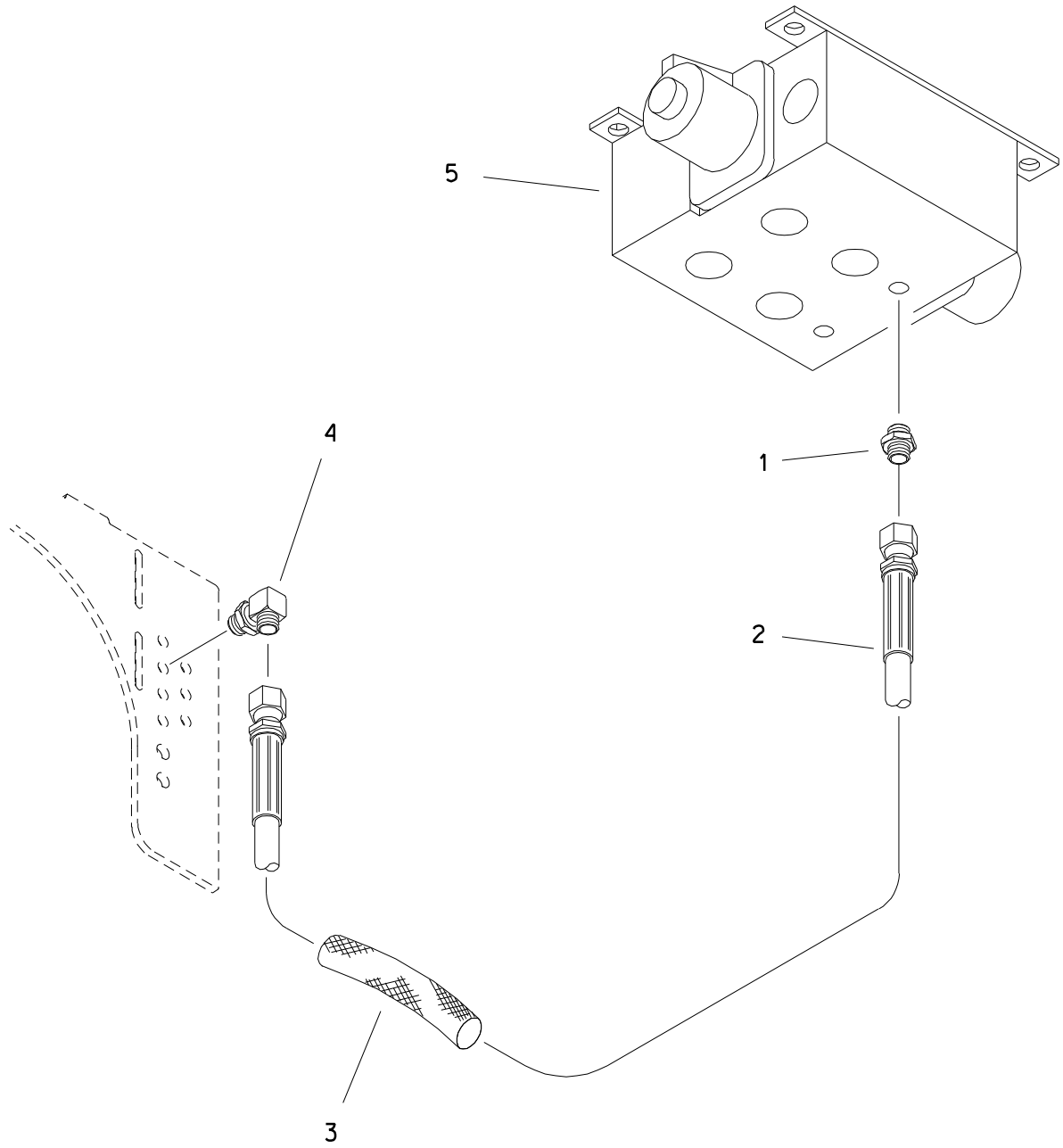

# THRUST PRESSURE GAUGE

REF NO.	PART NUMBER	QTY	DESCRIPTION	REMARKS
1.	154-278	1	CONNECTOR (04S-040)	
2.	515-170	1	HOSE (040FX-86"-3000)	
3.	117-398	1	ABRASION SLEEVE (1.00" X 86")	
4.	154-355	1	BK CONNECTOR (040-04090BK)	
5.	153-543	-	THRUST VALVE (ELECTRIC)	

FOOTNOTES

NOTE:  
REFER TO O-RING CHART (800-301) IN BACK OF THE BOOK FOR REPLACEMENT OF O-RINGS.

# THRUST LIMITER

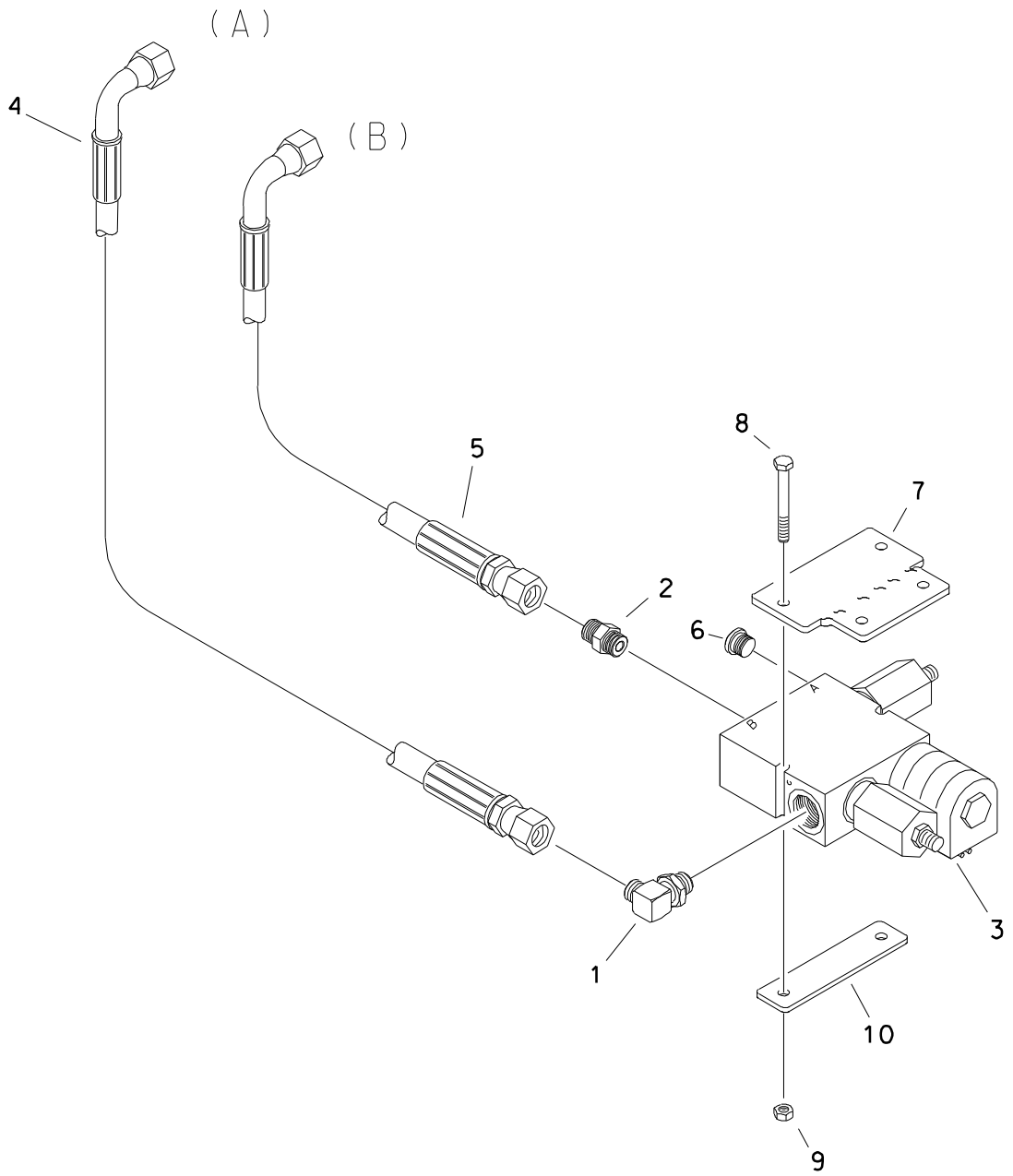

# THRUST LIMITER

REF NO.	PART NUMBER	QTY	DESCRIPTION	REMARKS
1.	154-276	1	CONNECTOR (040-08S90)	
2.	154-222	1	CONNECTOR (060-08S)	
3.	153-328	1	HYDRAULIC VALVE	
4.	515-011	1	HOSE (040FX90-32"-3000)	
5.	515-708	1	HOSE (060FX90-30"-4000)	
6.	155-074	1	PLUG (08S, SOC, FM)	SEE FOOTNOTE 3
7.	305-931	-	PLATE, VALVE MOUNT	
8.	106-893	2	SCREW (M6-1.00 X 55MM)	
9.	106-237	2	LOCKNUT (M6-1.00, PRV TRQ, NLK)	
10.	310-400	1	BACKUP PLATE	

FOOTNOTES

- 1. (A) CONNECTS TO LOAD SENSE TEE IN "Y" PORT ON THRUST VALVE
- 2. (B) CONNECTS TO TEE IN "B" PORT ON THRUST VALVE
- 3. IF FACTORY PLUG (HAS NO O-RING) IT IS TO BE INSTALLED, TORQUE TO 24 FT. LBS.  
IF A SERVICE PLUG (HAS O-RING) IT IS TO BE INSTALLED, TORQUE TO 72 FT. LBS.

NOTE

REFER TO O-RING CHART (800-301) IN BACK OF THE BOOK FOR REPLACEMENT OF O-RINGS

# THRUST DRIVE HYDRAULICS

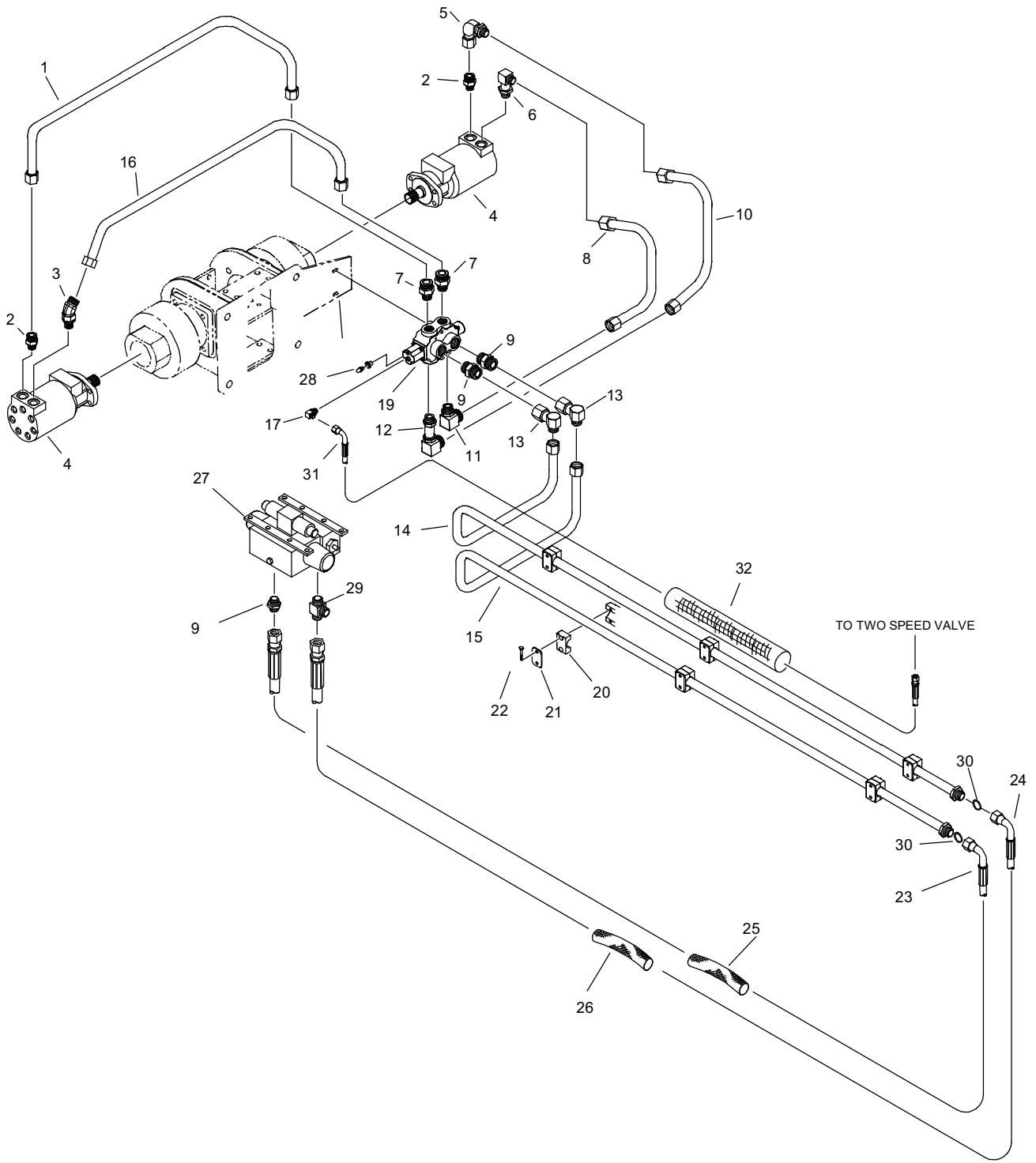

## THRUST DRIVE HYDRAULICS

REF NO.	PART NUMBER	QTY	DESCRIPTION	REMARKS
1.	149-386	1	HYD LINE (-12)	THRUST PORT, RH A
2.	154-247	2	CONNECTOR (10S-120)	
3.	154-336	1	CONNECTOR (10S-12045)	
4.	153-141	2	HYDRAULIC MOTOR	
5.	154-457	1	UNION (120-120FX90)	
6.	154-273	1	CONNECTOR (10S-12090)	
7.	154-269	2	CONNECTOR (12S-120)	
8.	149-385	1	HYD LINE (-12)	THRUST PORT, LH A
9.	154-281	3	CONNECTOR (16S-160)	
10.	149-384	1	HYD LINE (-12)	THRUST PORT, LH B
11.	154-270	1	CONNECTOR (12S-12090)	
12.	154-338	1	CONNECTOR (12S-12090, XL)	
13.	154-290	2	UNION (160-160FX90)	
14.	149-612	1	HYD LINE ( )	
15.	156-903	1	HYD LINE (160-160FX)	THRUST PRESSURE
16.	149-387	1	HYD LINE (-12)	THRUST PORT, RH B
17.	154-252	1	CONNECTOR (04S-04090)	
18.	343-453	1	MOUNT PLATE	
19.	149-343	1	HYDRAULIC CONTROL VALVE	
	190-863		SEAL REPAIR KIT	
	310-800	1	END CAP	
20.	110-573	6	BOLT-ON CLAMP (1", SOLD PER SET)	
21.	322-289	6	BACKUP (BOLT-ON)	
22.	105-818	12	BOLT (1/4-NC X 1-1/2")	
23.	515-722	1	HOSE (16FX90-60"-3000)	
24.	515-723	1	HOSE (16FX90-62"-3000)	
25.	117-295	1	ABRASION SLEEVE (2.07" X 60")	
26.	117-179	1	ABRASION SLEEVE (2.07" X 62")	
27.	153-543	-	THRUST VALVE (ELECTRIC)	
28.	163-101	1	BLEEDER VALVE	
29.	514-411	1	RUN TEE (16S-160-060)	
30.	155-714	2	O-RING (021 D90)	
31.	515-522	1	HOSE (040FX90-169"-3000)	
32.	117-759	1	ABRASION SLEEVE (1.00" X 160")	

NOT SHOWN:

FOOTNOTES:

**NOTE:**

REFER TO O-RING CHART (800-301) IN BACK OF THE BOOK FOR REPLACEMENT OF O-RINGS.

# ROTATION PRESSURE GAUGE

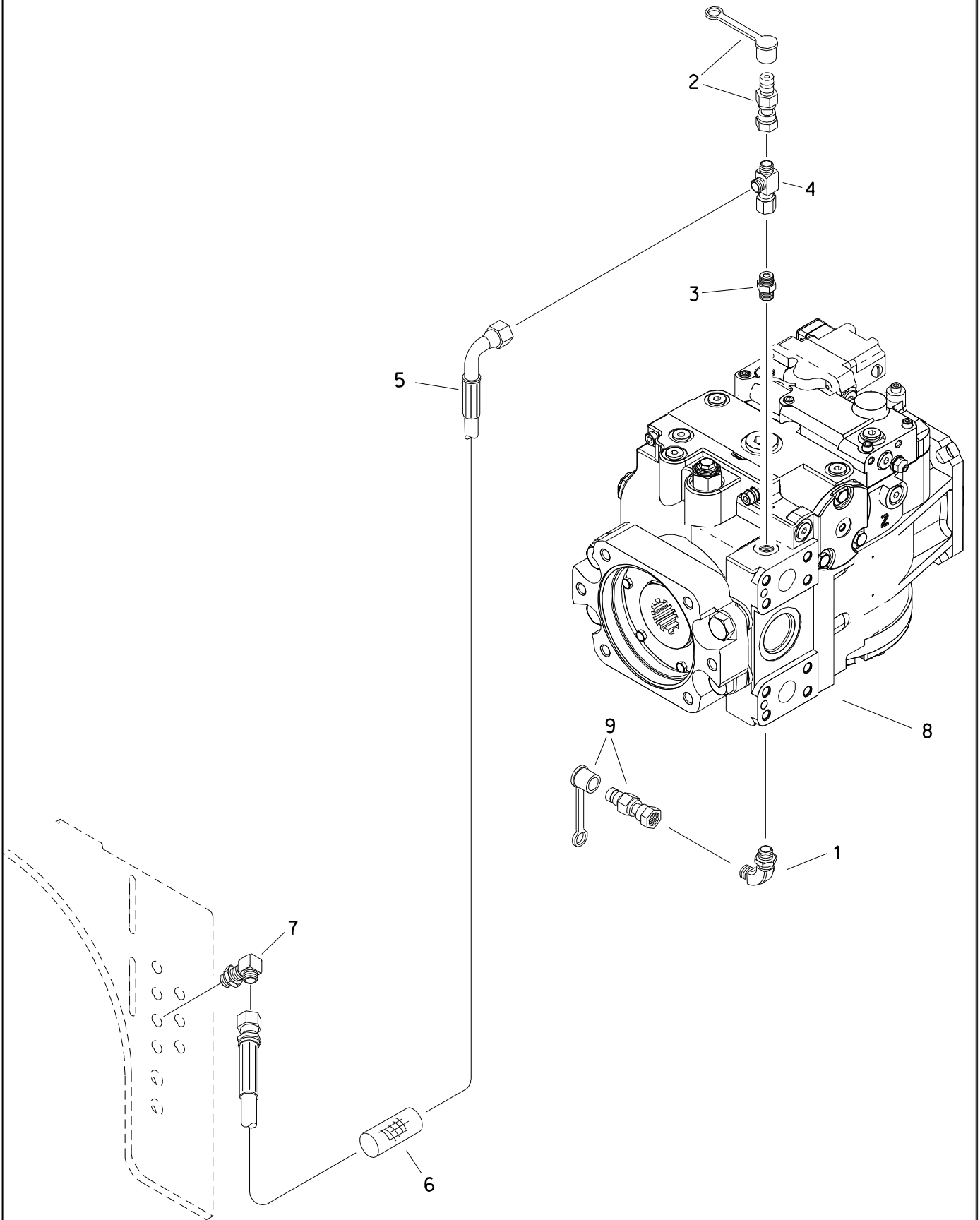



# ROTATION PRESSURE GAUGE

REF NO.	PART NUMBER	QTY	DESCRIPTION	REMARKS
1.	154-342	1	CONNECTOR (06S-06090)	
2.	159-156	1	QDC ADAPTER (02-040F)	
3.	154-220	1	CONNECTOR (040-06S)	
4.	154-265	1	UNION RUN TEE (040FX-040-040)	
5.	153-296	1	HOSE (040FX90M-66"-5000)	
6.	117-419	1	ABRASION SLEEVE (1.00" X 66")	
7.	154-355	1	BK CONNECTOR (040-04090BK)	
8.	153-105	-	PUMP, HYDRAULIC	
9.	159-157	1	QDC ADAPTER (02-060F)	

FOOTNOTES

# INNER ROTATION PRESSURE GAUGE

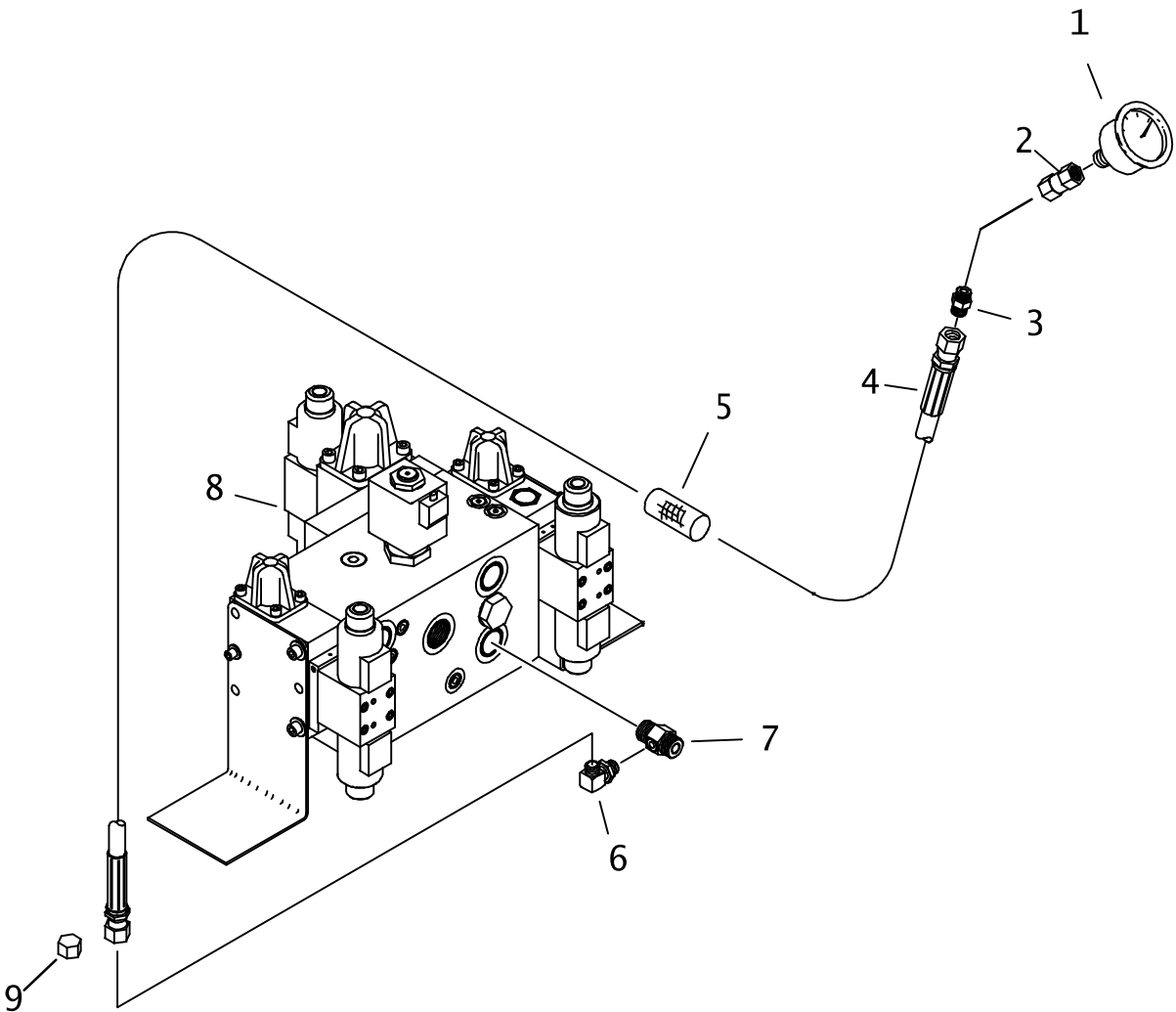

## INNER ROTATION PRESSURE GAUGE

REF NO.	PART NUMBER	QTY	DESCRIPTION	REMARKS
1.	258-036	1	HYD PRESSURE GAUGE (6000 PSI)	
2.	514-408	1	COLLAR (04NF)	
3.	154-339	1	CONNECTOR (04N-040)	
4.	154-724	1	HOSE (040FX-82"-3000)	
5.	117-413	1	ABRASION SLEEVE (1.00" X 84")	
6.	154-252	1	CONNECTOR (04S-04090)	
7.	149-636	-	TEE (12S-04SF-160, SPECIAL)	
8.	150-2251	-	HYDRAULIC CONTROL VALVE	
9.	154-296	1	CAP (040F)	REPLACES REF NO'S 1-5 ON JT2720 MACH 1 ONLY

NOT SHOWN:

FOOTNOTES:

NOTE:

# INNER ROTATION HYDRAULICS

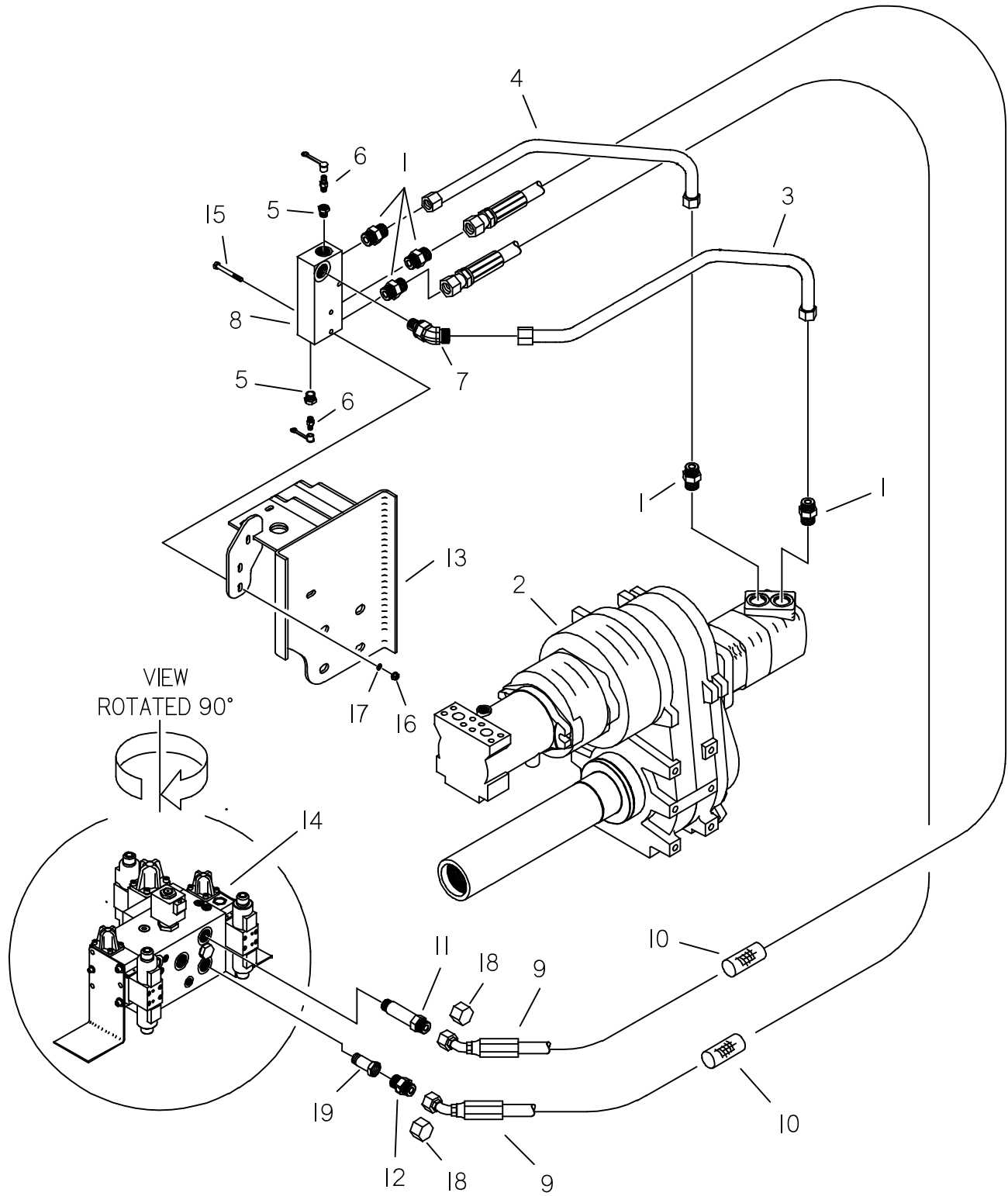

## INNER ROTATION HYDRAULICS

REF NO.	PART NUMBER	QTY	DESCRIPTION	REMARKS
1.	154-281	5	CONNECTOR (16S-16O)	
2.	166-286	-	AT2720 SPINDLE DRIVE ASS'Y	OBSOLETE
	197-090	-	REMANUFACTURED 166-286 SPNDL	
3.	153-237	1	HYDRAULIC LINE (-16)	
4.	153-236	1	HYDRAULIC LINE (-16)	
5.	155-171	2	REDUCER (10S-06SF)	
6.	159-147	2	QDC ADAPTER (02-06S)	
7.	154-388	1	CONNECTOR (16S-16O45)	
8.	153-228	1	MANIFOLD BLOCK	
9.	153-312	2	HOSE (16OFX45-172'-3000)	
10.	117-292	2	ABRASION SLEEVE (2.07" X 70")	
11.	153-539	1	ADAPTER (12S-16O, SPECIAL)	
12.	149-636	1	TEE (12S-04SF-16O, SPECIAL)	
13.	309-775	-	HOSE TRACK MOUNT WELDMENT	
14.	150-2251	1	HYDRAULIC CONTROL VALVE	
15.	106-330	3	SCREW (M8-1.25 X 70MM)	
16.	106-561	3	LOCKNUT (M8-1.25,PRV TRQ, 10.9)	
17.	105-117	3	WASHER (5/16")	
18.	154-329	2	CAP (16OF)	SEE FOOTNOTE 1
19.	153-540	1	CONNECTOR (12S-12SF, SPECIAL)	

NOT SHOWN:

**FOOTNOTES:**

REPLACES REF NO'S 1-10 AND 15-17 ON JT2720 MACH I ONLY.

NOTE:

# OUTER ROTATION HYDRAULICS

JT2720 MACH 1 ONLY

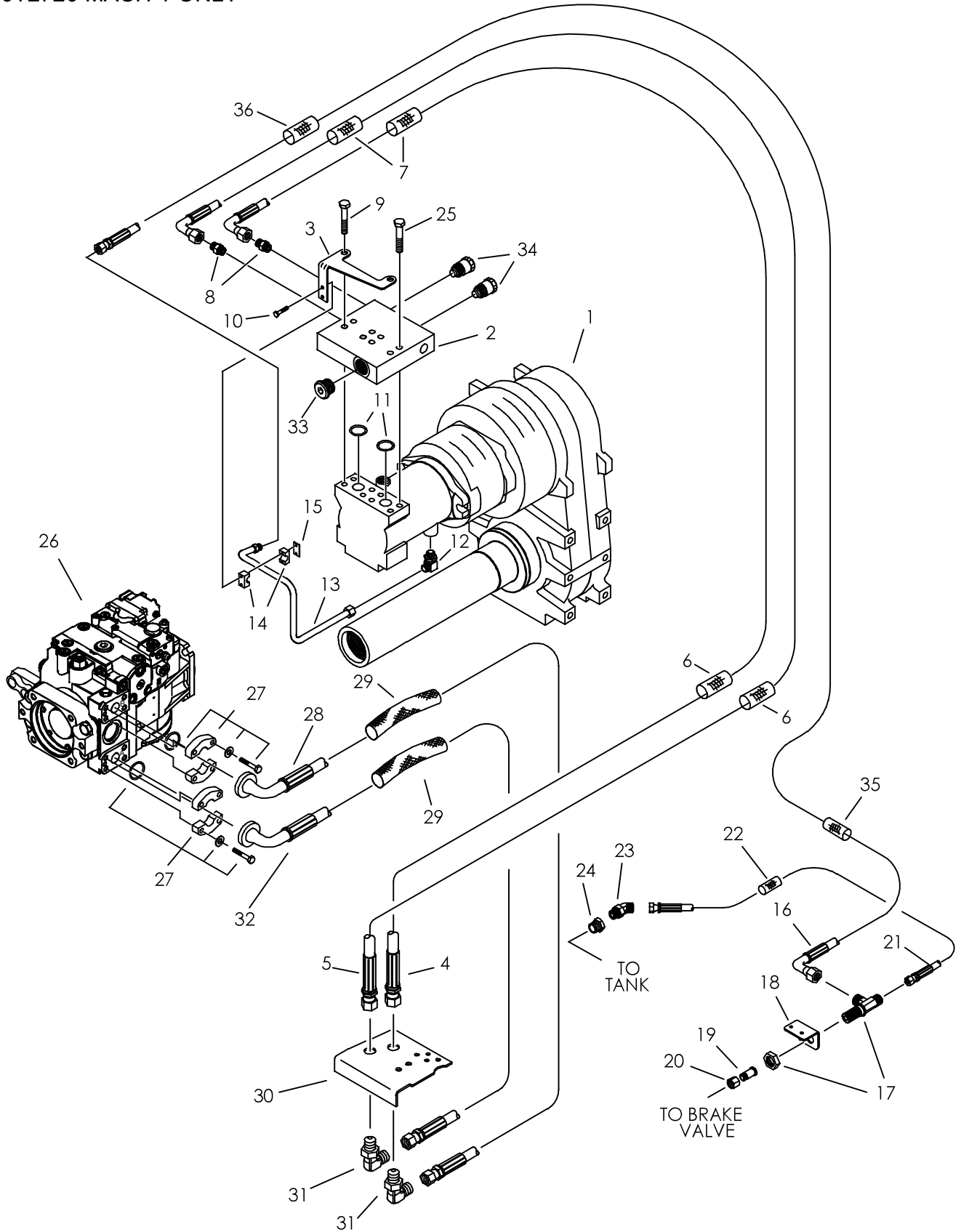

## OUTER ROTATION HYDRAULICS

### JT2720 MACH 1 ONLY

REF NO.	PART NUMBER	QTY	DESCRIPTION	REMARKS
1.	166-272	-	SPINDLE DRIVE PARTS ASS'Y	45769800LKM
2.	153-187	1	SPIKE MANIFOLD	OBSOLETE
3.	309-907	1	BRACKET	
4.	153-400	1	HOSE (160FX90M-170"-5000)	
5.	153-401	1	HOSE (160FX90M-173"-5000)	
6.	117-295	2	ABRASION SLEEVE (2.07" X 60")	
7.	117-296	2	ABRASION SLEEVE (2.07" X 30")	
8.	154-281	2	CONNECTOR (16S-160)	
9.	106-335	2	SCREW (M12-1.75 X 70MM)	TORQUE TO 70 FT-LBS
10.	105-818	2	BOLT (1/4-NC X 1-1/2")	
11.	157-029	2	O-RING (219 D90)	
12.	153-362	1	ELBOW (M22-1.5 PSEAL X 08090)	
13.	149-534	1	HYDRAULIC LINE (-08)	
14.	110-866	1	CLAMP (1/2")	
15.	110-783	1	WELD PLATE	
16.	153-402	1	HOSE (080FX90M-159"-3000)	
17.	154-295	1	BK RUN TEE (080-080-080BK)	
18.	309-891	1	BRACKET	
19.	154-248	1	REDUCER STEM (040)	
20.	154-272	1	REDUCER NUT (080F)	
21.	153-303	1	HOSE (080FX-65"-3000)	
22.	117-391	1	ABRASION SLEEVE (1.25" X 66")	
23.	154-264	1	CONNECTOR (080-10S45)	
24.	510-017	1	REDUCER (12S-10SF)	
25.	107-507	6	SCREW (M12-1.75X65MM) FULL THD	TORQUE TO 70 FT-LBS
26.	153-105	-	HYDRAULIC PUMP	
27.	159-077	2	SPLIT FLANGE (16SFL)	
	105-222	4	BOLT (7/16-NC X 1-3/4")	
	105-073	4	LOCK WASHER (7/16")	
	157-029	2	O-RING (219 D90)	
28.	515-705	1	HOSE (16FL90-160FX-38.5"-3000)	
29.	117-296	2	ABRASION SLEEVE (2.07" X 30")	
30.	305-710	-	MAIN FRAME	
31.	154-419	2	BK CONNECTOR (160-16090BK)	
32.	154-803	1	HOSE (16FL90-160FX-33.5"-5000)	
33.	155-184	1	PLUG (16S)	
34.	149-497	2	HYDRAULIC VALVE	TORQUE TO 85 FT-LBS
35.	117-214	1	ABRASION SLEEVE (1.25" X 40")	
36.	117-396	1	ABRASION SLEEVE (1.25" X 28")	

NOT SHOWN:

FOOTNOTES:

NOTE:

# OUTER ROTATION HYDRAULICS

JT2720 MACH 1 ALL TERRAIN ONLY

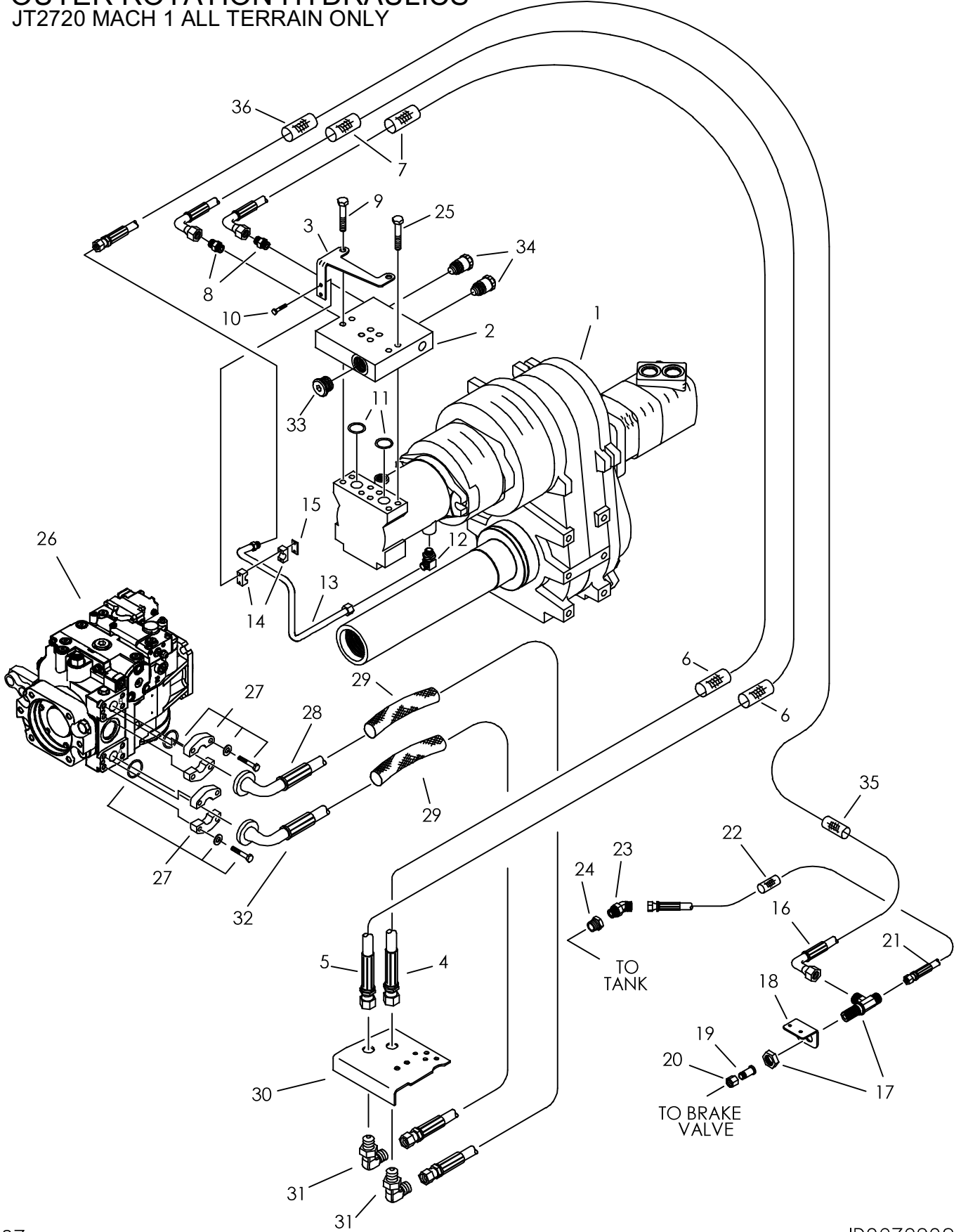



## OUTER ROTATION HYDRAULICS JT2720 MACH 1 ALL TERRAIN ONLY

REF NO.	PART NUMBER	QTY	DESCRIPTION	REMARKS
1.	166-455	-	AT SPNDL DRV PRTS ASS'Y	BEGINS WITH S/N 2X0001
	166-286	-	AT2720 SPINDLE DRIVE ASS'Y	ENDS WITH S/N 2W0799
	197-090	-	REMANUFACTURED 166-286 SPNDL	
2.	153-187	1	SPIKE MANIFOLD	OBSOLETE
3.	309-907	1	BRACKET	
4.	153-313	1	HOSE (160FX90M-174"-5000)	
5.	153-314	1	HOSE (160FX90M-177"-5000)	
6.	117-295	2	ABRASION SLEEVE (2.07" X 60")	
7.	117-296	2	ABRASION SLEEVE (2.07" X 30")	
8.	154-281	2	CONNECTOR (16S-160)	
9.	106-335	2	SCREW (M12-1.75 X 70MM)	TORQUE TO 70 FT-LBS
10.	105-818	2	BOLT (1/4-NC X 1-1/2")	
11.	157-029	2	O-RING (219 D90)	
12.	153-362	1	ELBOW (M22-1.5 PSEAL X 08090)	
13.	149-534	1	HYDRAULIC LINE (-08)	
14.	110-866	1	CLAMP (1/2")	
15.	110-783	1	WELD PLATE	
16.	153-302	1	HOSE (080FX90M-163"-3000)	
17.	154-295	1	BK RUN TEE (080-080-080BK)	
18.	309-891	1	BRACKET	
19.	154-248	1	REDUCER STEM (040)	
20.	154-272	1	REDUCER NUT (080F)	
21.	153-303	1	HOSE (080FX-65"-3000)	
22.	117-391	1	ABRASION SLEEVE (1.25" X 66")	
23.	154-264	1	CONNECTOR (080-10S45)	
24.	510-017	1	REDUCER (12S-10SF)	
25.	107-507	6	SCREW (M12-1.75X65MM) FULL THD	TORQUE TO 70 FT-LBS
26.	153-105	-	HYDRAULIC PUMP	
27.	159-077	2	SPLIT FLANGE (16SFL)	
	105-222	4	BOLT (7/16-NC X 1-3/4")	
	105-073	4	LOCK WASHER (7/16")	
	157-029	2	O-RING (219 D90)	
28.	515-705	1	HOSE (16FL90-160FX-38.5"-3000)	
29.	117-296	2	ABRASION SLEEVE (2.07" X 30")	
30.	305-710	-	MAIN FRAME	
31.	154-419	2	BK CONNECTOR (160-16090BK)	
32.	154-803	1	HOSE (16FL90-160FX-33.5"-5000)	
33.	155-184	1	PLUG (16S)	
34.	149-497	2	HYDRAULIC VALVE	TORQUE TO 85 FT-LBS
35.	117-214	1	ABRASION SLEEVE (1.25" X 40")	
36.	117-396	1	ABRASION SLEEVE (1.25" X 28")	

NOT SHOWN:

FOOTNOTES:

NOTE:

# ROTATION MOTOR HOT OIL HYDRAULIC JT2720 MACH 1 ONLY

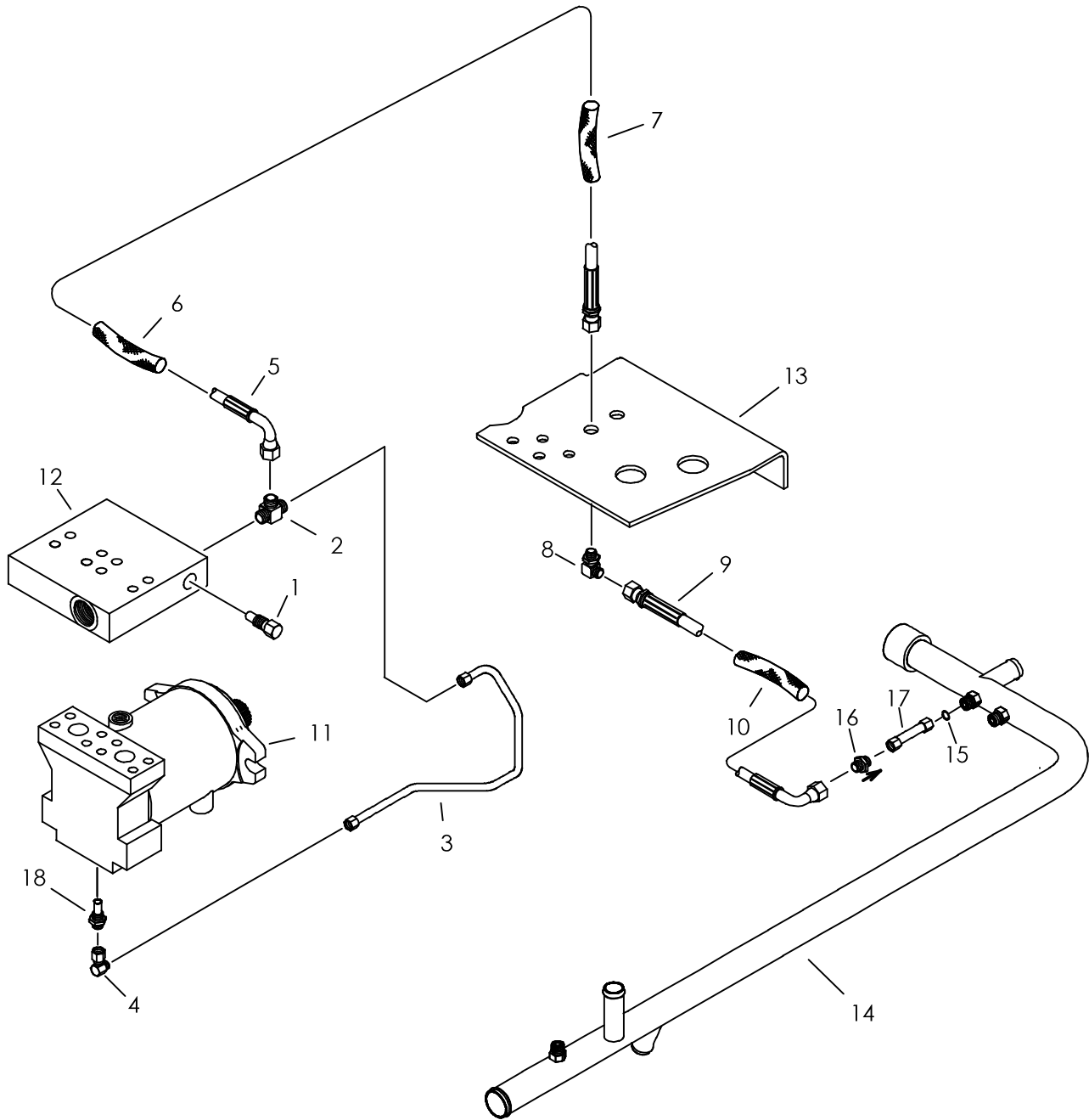

## ROTATION MOTOR HOT OIL HYDRAULIC JT2720 MACH 1 ONLY

REF NO.	PART NUMBER	QTY	DESCRIPTION	REMARKS
1.	153-275	1	FLOW CONTROL CARTRIDGE	
2.	154-345	1	RUN TEE (06S-060-060)	
3.	153-342	1	HYDRAULIC LINE (-06)	
4.	154-228	1	UNION (060-060FX90)	TORQUE TO 30-33 LB-FT.
5.	156-936	1	HOSE (060FX90-170"-3000)	
6.	117-676	1	ABRASION SLEEVE (1.00" X 30")	
7.	117-714	1	ABRASION SLEEVE (1.00" X 54")	
8.	154-229	1	BK CONNECTOR (060-06090BK)	
9.	515-716	1	HOSE (060FX90-42"-3000)	
10.	117-717	1	ABRASION SLEEVE (1.00" X 40")	
11.	149-970	-	HYDRAULIC MOTOR	
	197-095	-	REMANUFACTURED 149-970 MOTOR	
	191-250	1	SEAL KIT	
	599-284	-	SHUTTLE UPGRADE KIT	
12.	153-187	-	SPIKE MANIFOLD	OBSOLETE
13.	305-710	-	MAIN FRAME	
14.	156-905	-	HYD LINE (24)	
15.	157-038	1	O-RING (012 D90)	
16.	149-871	1	FLOW CHECK VALVE(060-060)	
17.	159-525	1	HYD LINE (-06)	
18.	159-538	1	ADAPTER (M14-1.50-060)	TORQUE TO 40-44 LB-FT.

NOT SHOWN:

FOOTNOTES:

NOTE:

# ROTATION MOTOR HOT OIL HYDRAULIC JT2720 MACH 1 ALL TERRAIN ONLY

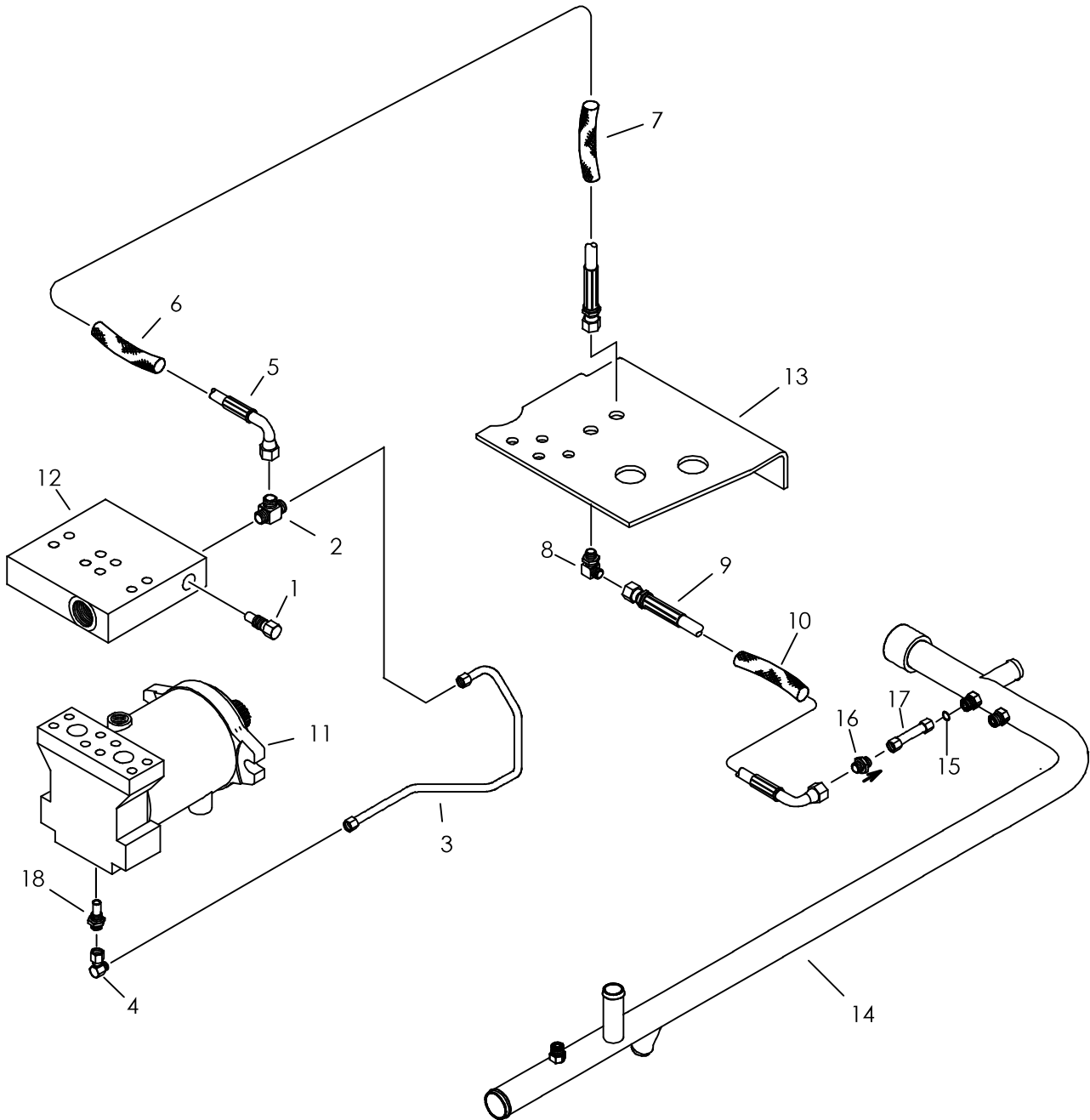

## ROTATION MOTOR HOT OIL HYDRAULIC JT2720 MACH 1 ALL TERRAIN ONLY

REF NO.	PART NUMBER	QTY	DESCRIPTION	REMARKS
1.	153-275	1	FLOW CONTROL CARTRIDGE	
2.	154-345	1	RUN TEE (06S-060-060)	
3.	153-342	1	HYDRAULIC LINE (-06)	
4.	154-228	1	UNION (060-060FX90)	TORQUE TO 30-33 LB-FT.
5.	153-388	1	HOSE (060FX90S-174"-3000)	
6.	117-676	1	ABRASION SLEEVE (1.00" X 30")	
7.	117-714	1	ABRASION SLEEVE (1.00" X 54")	
8.	154-229	1	BK CONNECTOR (060-06090BK)	
9.	515-716	1	HOSE (060FX90-42"-3000)	
10.	117-717	1	ABRASION SLEEVE (1.00" X 40")	
11.	149-970	-	HYDRAULIC MOTOR	
	197-095	-	REMANUFACTURED 149-970 MOTOR	
	191-250	1	SEAL KIT	
	599-284	-	SHUTTLE UPGRADE KIT	
12.	153-187	-	SPIKE MANIFOLD	OBSOLETE
13.	305-710	-	MAIN FRAME	
14.	156-905	-	HYD LINE (24)	
15.	157-038	1	O-RING (012 D90)	
16.	149-871	1	FLOW CHECK VALVE(060-060)	
17.	159-525	1	HYD LINE (-06)	
18.	159-538	1	ADAPTER (M14-1.50-060)	TORQUE TO 40-44 LB-FT.

NOT SHOWN:

FOOTNOTES:

NOTE:

# ROTATION BRAKE HYDRAULICS

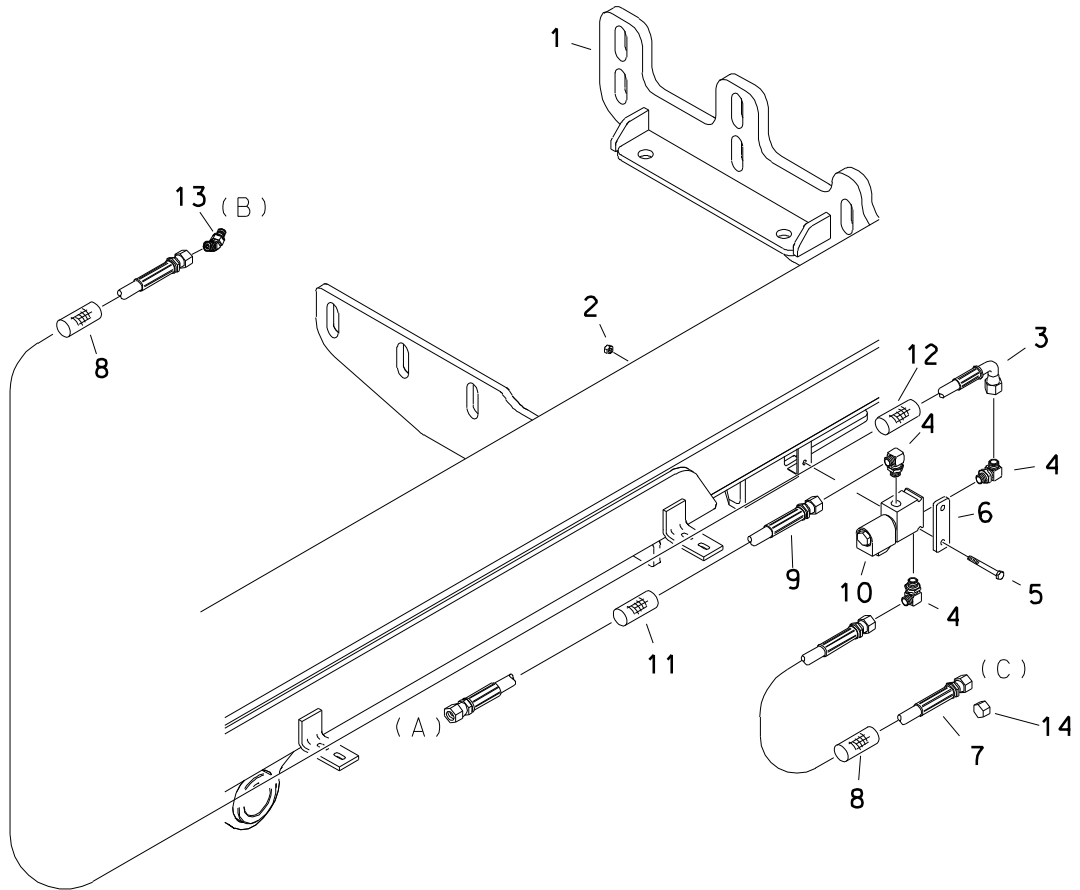

# ROTATION BRAKE HYDRAULICS

REF NO.	PART NUMBER	QTY	DESCRIPTION	REMARKS
1.	303-648	-	DRILL FRAME WLD MN'T	
2.	105-085	2	LOCKNUT (1/4-NC)	
3.	153-297	1	HOSE (040FX90M-198"-3000)	
4.	154-226	3	CONNECTOR (040-06S90)	
5.	107-215	2	FLG LK BLT (1/4-NC X 2-1/4")	
6.	343-342	1	FLOW DIVIDER BRACKET	
7.	154-800	1	HOSE (040FX-18"-3000)	
8.	117-328	2	ABRASION SLEEVE (1.00" X 18")	
9.	154-653	1	HOSE (040FX-40"-3000)	
10.	158-627	1	SOLENOID VALVE	
11.	117-717	1	ABRASION SLEEVE (1.00" X 40")	
12.	117-398	1	ABRASION SLEEVE (1.00" X 86")	
13.	154-263	1	CONNECTOR (04S-04045)	
14.	154-296	1	CAP (040F)	REPLACES REF NO'S 2 THRU 13 ON JT2720 MACH 1 ONLY

FOOTNOTES

- 1. (A) CONNECTS TO REDUCER ON BULKHEAD RUN TEE
- 2. (B) CONNECTS TO PORT IN BRAKE
- 3. (C) CONNECTS TO TEE IN FRONT WRENCH VALVE

NOTE

REFER TO O-RING CHART (800-301) IN BACK OF THE BOOK FOR REPLACEMENT OF O-RINGS

# GROUND DRIVE CONTROL HYDRAULICS

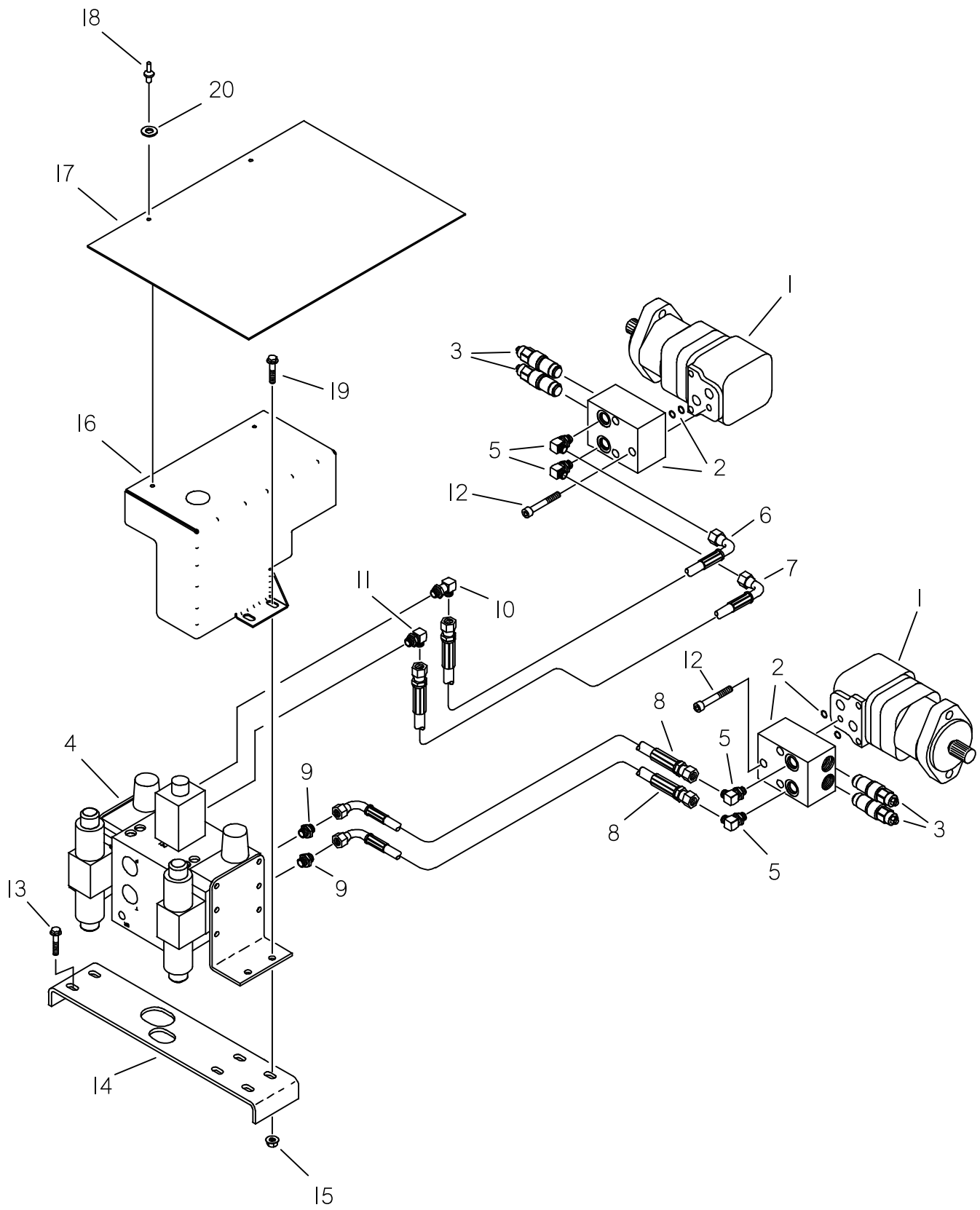



## GROUND DRIVE CONTROL HYDRAULICS

REF NO.	PART NUMBER	QTY	DESCRIPTION	REMARKS
1.	158-953	2	HYD MOTOR	
	500-658	-	SEAL REPAIR KIT	
2.	153-143	2	COUNTERBALANCE MANIFOLD	
	155-776	-	O-RING (117 D70)	
3.	158-018	4	RELIEF CARTRIDGE	
4.	150-225	1	HYDRAULIC CONTROL VALVE	
	501-904	-	FLOW CONTROL VALVE	
5.	154-323	4	CONNECTOR (08S-10090)	
6.	153-294	1	HOSE (100FX90S-17"-3000)	
7.	153-295	1	HOSE (100FX90S-18"-3000)	
8.	515-720	2	HOSE (100FX90S-32"-3000)	
9.	154-288	1	CONNECTOR (10S-10090, XL)	
10.	154-288	1	CONNECTOR (10S-10090, XL)	
11.	154-298	1	CONNECTOR (10S-10090)	
12.	105-857	6	BOLT (3/8-NC X 3", SOC, GD8)	
13.	106-724	2	FLG SCREW (M10-1.50 X 25MM)	
14.	305-710	-	MAIN FRAME	
15.	106-387	4	FLG LOCKNUT (M10-1.50)	
16.	320-230	1	GROUND DRIVE VALVE COVER	
17.	117-307	1	FLAP	
18.	110-560	2	POP RIVET (3/16" X 1/2", ALUM)	
19.	106-383	2	FLG LK SCREW (M10-1.50 X 30MM)	
20.	105-284	2	WASHER (3/16")	

NOT SHOWN:

FOOTNOTES:

NOTE:

REFER TO O-RING CHART (800-301) IN BACK OF THE BOOK FOR REPLACEMENT OF O-RINGS.

# BRAKE LINE

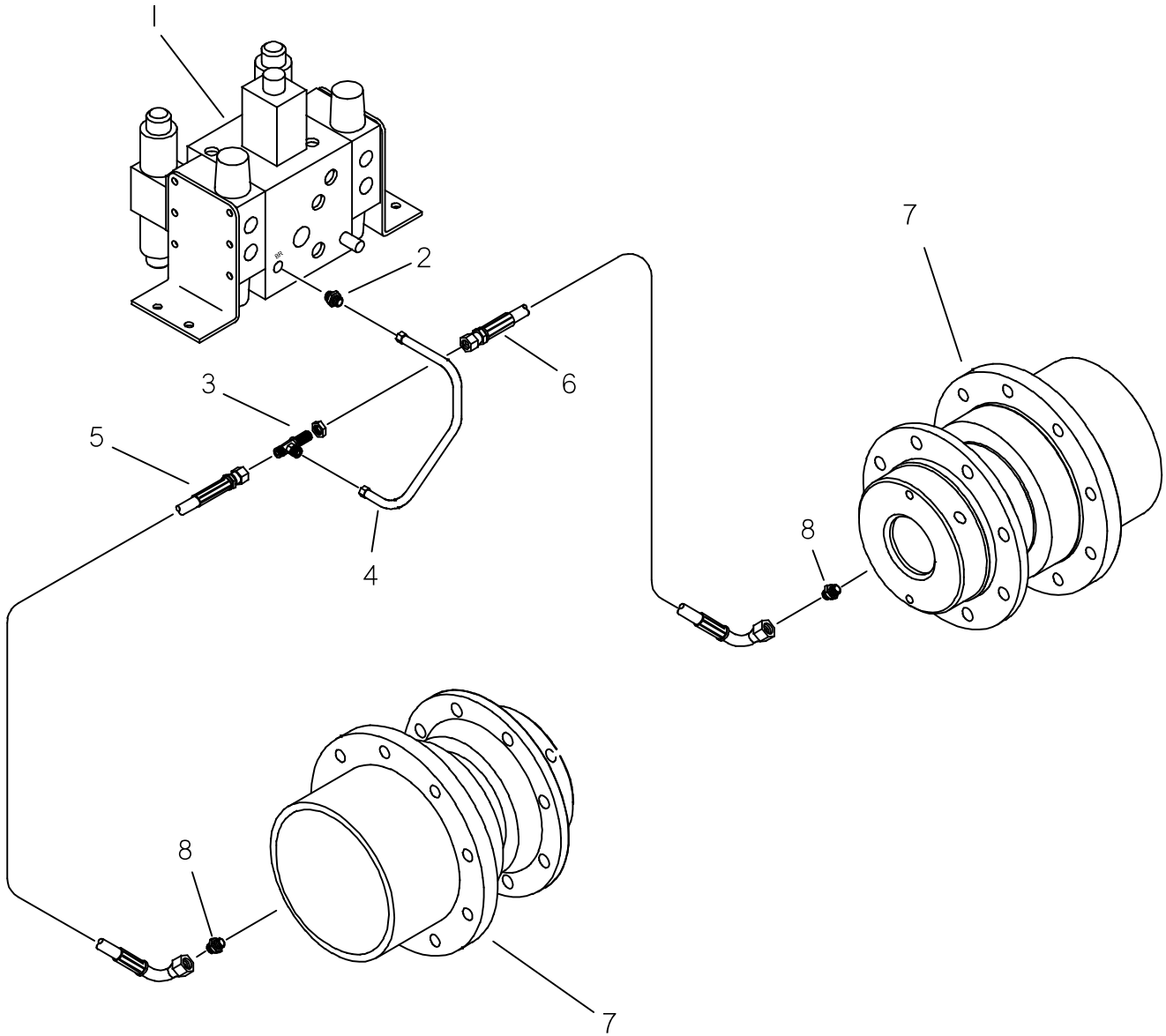

# BRAKE LINE

REF NO.	PART NUMBER	QTY	DESCRIPTION	REMARKS
1.	150-225	-	HYDRAULIC CONTROL VALVE	
2.	154-221	1	CONNECTOR (06S-060)	
3.	154-400	1	BK RUN TEE (060-060-060BK)	
4.	149-401	1	HYDRAULIC LINE (1-06)	BRAKE LINE
5.	153-315	1	HOSE (060FX90S-36"-3000)	
6.	153-316	1	HOSE (060FX90S-25"-3000)	
7.	166-140	2	PLANETARY GEAR BOX	TRACK
8.	154-411	2	CONNECTOR (04S-060)	

NOT SHOWN:

FOOTNOTES:

NOTE:  
REFER TO O-RING CHART (800-301) IN BACK OF THE BOOK FOR REPLACEMENT OF O-RINGS

# LOAD SENSE HYDRAULICS

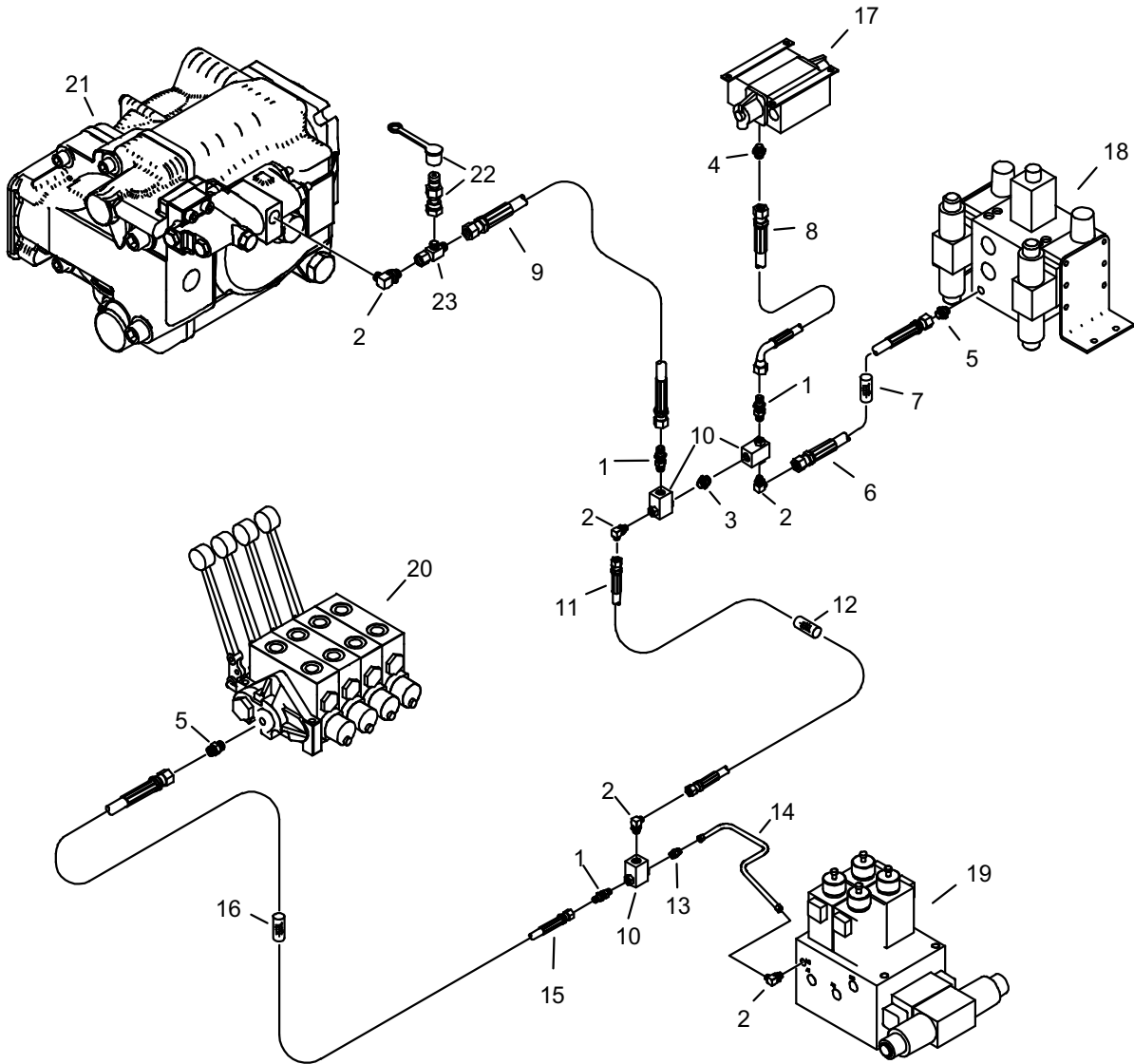

## LOAD SENSE HYDRAULICS

REF NO.	PART NUMBER	QTY	DESCRIPTION	REMARKS
1.	149-518	3	CONNECTOR (06S-040)	
2.	154-226	5	CONNECTOR (040-06S90)	
3.	155-153	1	CONNECTOR (06S-06S)	
4.	154-316	1	RUN TEE (04S-040-040)	
5.	154-278	2	CONNECTOR (04S-040)	
6.	154-702	1	HOSE (040FX-30"-3000)	
7.	117-676	1	ABRASION SLEEVE (1.00" X 30")	
8.	515-683	1	HOSE (040FX90-28"-3000)	
9.	515-735	1	HOSE (040FX-22"-3000)	
10.	158-600	3	HYD SHUTTLE VALVE	
11.	154-966	1	HOSE (040FX-95"-3000)	
12.	117-213	1	ABRASION SLEEVE (1.00" X 96")	
13.	154-220	1	CONNECTOR (040-06S)	
14.	149-648	1	HYDRAULIC LINE (-04)	
15.	153-299	1	HOSE (040FX-84"-3000)	
16.	117-413	1	ABRASION SLEEVE (1.00" X 84")	
17.	153-543	1	THRUST VALVE (ELECTRIC)	
18.	150-2251	1	HYDRAULIC CONTROL VALVE	
	501-904	-	FLOW CONTROL VALVE	
	500-1362	-	COMPENSATOR VALVE	
	500-1363	-	COMPENSATOR VALVE - SEAL KIT	
19.	149-258	1	HYDRAULIC VALVE	
20.	158-064	1	HYD CONTROL VALVE	
21.	149-390	1	HYDRAULIC PUMP	
22.	159-156	1	QDC ADAPTER (02-040F)	
23.	154-265	1	UNION RUN TEE (040FX-040-040)	

NOT SHOWN:

FOOTNOTES:

NOTE:

REFER TO O-RING CHART (800-301) IN BACK OF THE BOOK FOR REPLACEMENT OF O-RINGS

# LOAD SENSE PRESSURE HYDRAULICS

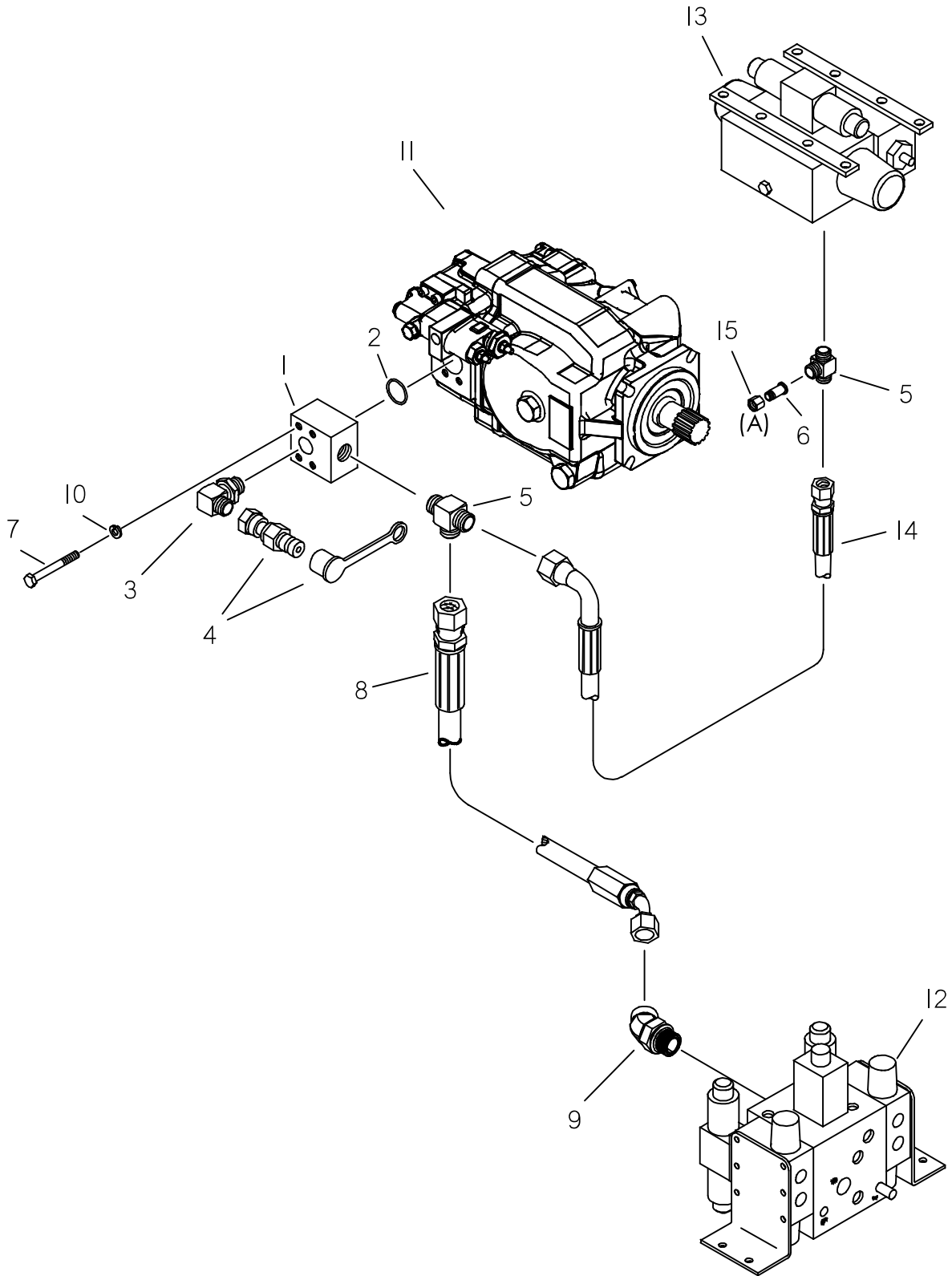

## LOAD SENSE PRESSURE HYDRAULICS

REF NO.	PART NUMBER	QTY	DESCRIPTION	REMARKS
1.	149-605	1	BLOCK, MANIFOLD, HORTON	
2.	157-078	1	O-RING ( 22 D90)	
3.	154-226	1	CONNECTOR (040-06S90)	
4.	159-156	1	QDC ADAPTER (02-040F)	
	159-148	1	DUST CAP (1/8")	
5.	154-359	2	RUN TEE (16S-160-160)	
6.	154-442	1	REDUCER STEM (100)	
7.	105-136	4	BOLT (1/2-NC X 3-1/2", GD 8)	
8.	153-311	1	HOSE (160FX45-54"-3000)	
9.	154-388	1	CONNECTOR (16S-16045)	
10.	105-070	4	LOCK WASHER (1/2")	
11.	149-390	-	HYDRAULIC PUMP	
12.	150-2251	-	HYDRAULIC CONTROL VALVE	
13.	153-543	-	THRUST VALVE (ELECTRIC)	
14.	153-418	1	HOSE (160FX90S-52"-3000)	
15.	154-340	1	REDUCER NUT (160F)	

NOT SHOWN:

FOOTNOTES:

(A) PRESSURE SUPPLY TO PARKER FRONT WRENCH VALVE AND GRESEN ANCHOR VALVE.

NOTE:

REFER TO O-RING CHART (800-301) IN BACK OF THE BOOK FOR REPLACEMENT OF O-RINGS.

## LOAD SENSE PUMP/CASE DRAIN

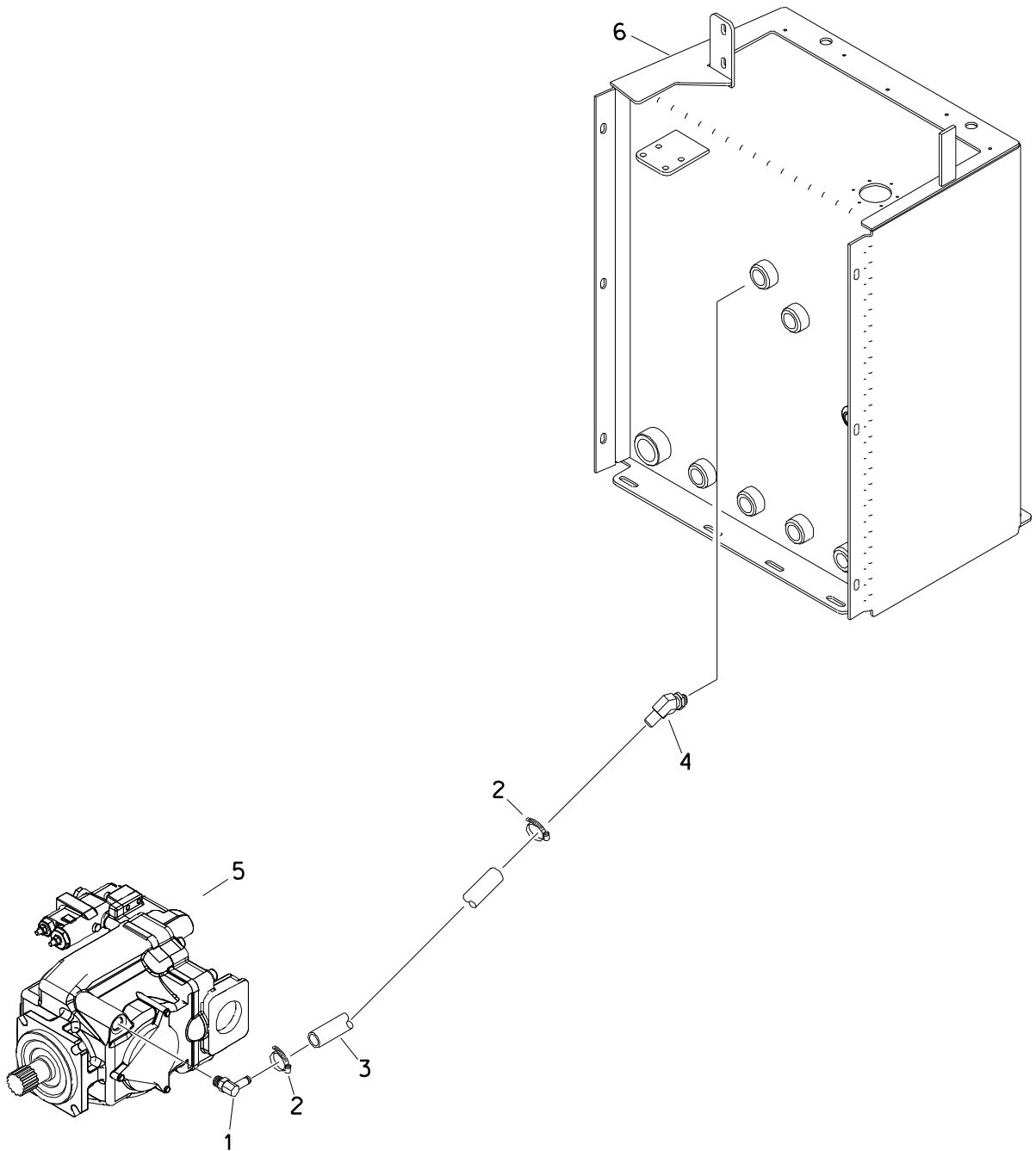



# LOAD SENSE PUMP/CASE DRAIN

REF NO.	PART NUMBER	QTY	DESCRIPTION	REMARKS
1.	154-362	1	S/O COUPLER (10S-12H90)	
2.	110-026	2	WORM CLAMP (1/2" TO 1-1/4")	
3.	116-636	1	BULK HOSE (3/4", SOLD PER 1')	USE 1 @ 11"
4.	155-196	1	S/O COUPLER (12S-12H45)	
5.	149-390	1	HYDRAULIC PUMP	
	499-063	-	SHAFT (SPLINED 14T)	
	190-803	-	SEAL REPAIR KIT	
	499-064	-	LOAD SENSE CONTROL	
	190-804	-	BEARING KIT	
6.	149-468	1	HYDRAULIC TANK WELDMENT	

FOOTNOTES

NOTE  
REFER TO O-RING CHART (800-301) IN BACK OF THE BOOK FOR REPLACEMENT OF O-RINGS.

# LOAD SENSE RETURN HYDRAULICS

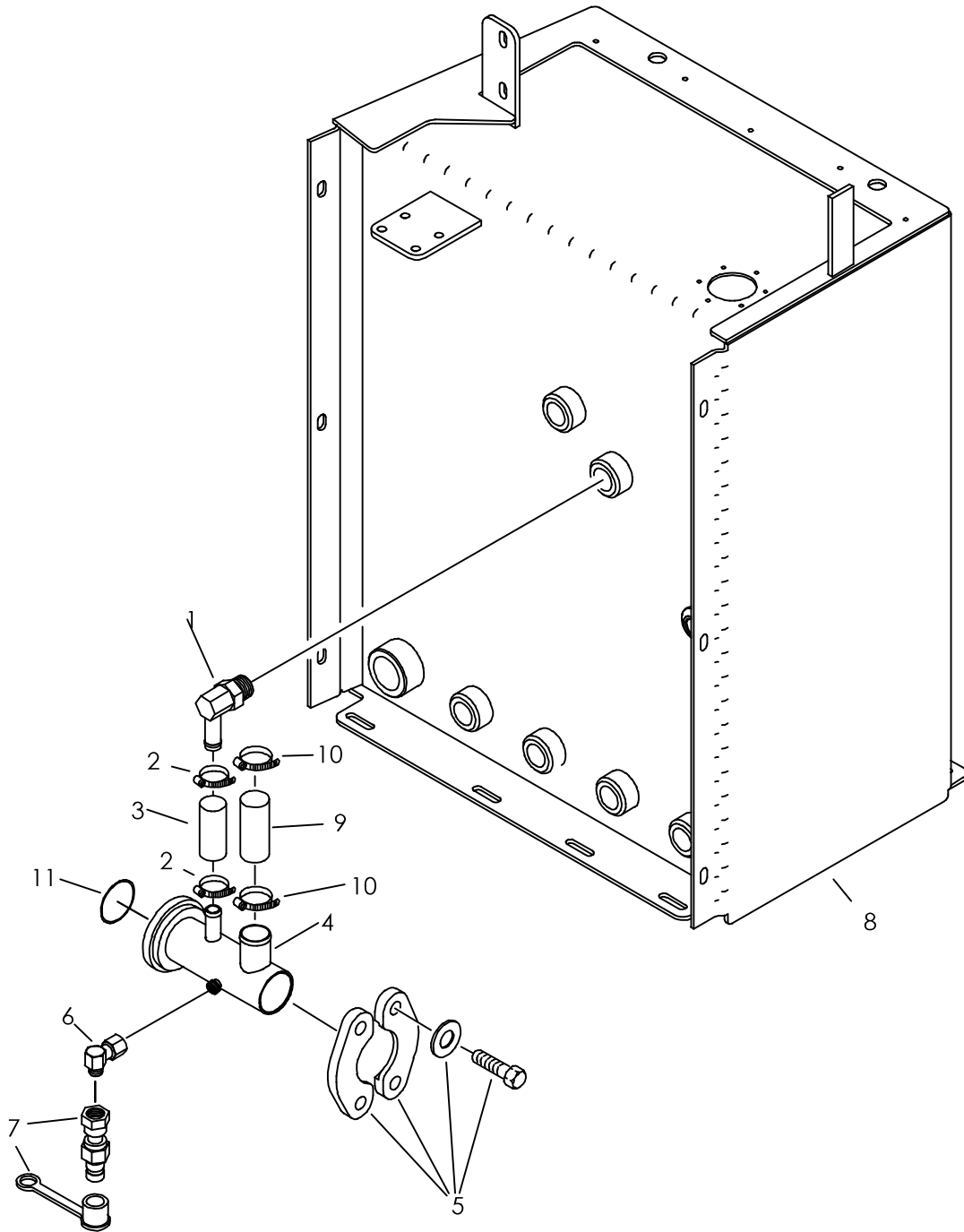

## LOAD SENSE RETURN HYDRAULICS

REF NO.	PART NUMBER	QTY	DESCRIPTION	REMARKS
1.	514-344	1	S/O COUPLER (12S-10H90)	
2.	110-217	2	WORM CLAMP (7/16" TO 1")	
3.	117-462	AR	BULK HOSE (5/8", SOLD PER 1")	USE 1 @ 7"
4.	514-448	1	S/O TEE COUPLER (40F-24H-16H)	
5.	514-447	1	SPLIT FLANGE KIT (-40)	
6.	154-255	1	UNION (040-040FX90)	
7.	159-156	1	QDC ADAPTER (02-040F)	
8.	149-468	-	HYDRAULIC TANK	
9.	116-588	1	BULK HOSE (1-1/2", SOLD PER 1')	USE 1 @ 14.75"
10.	111-028	2	T-BOLT CLAMP (1.75"-2.00")	
11.	157-015	1	O-RING (232 D70)	

NOT SHOWN:

FOOTNOTES:

NOTE:

# RIGHT CONSOLE HYDRAULICS

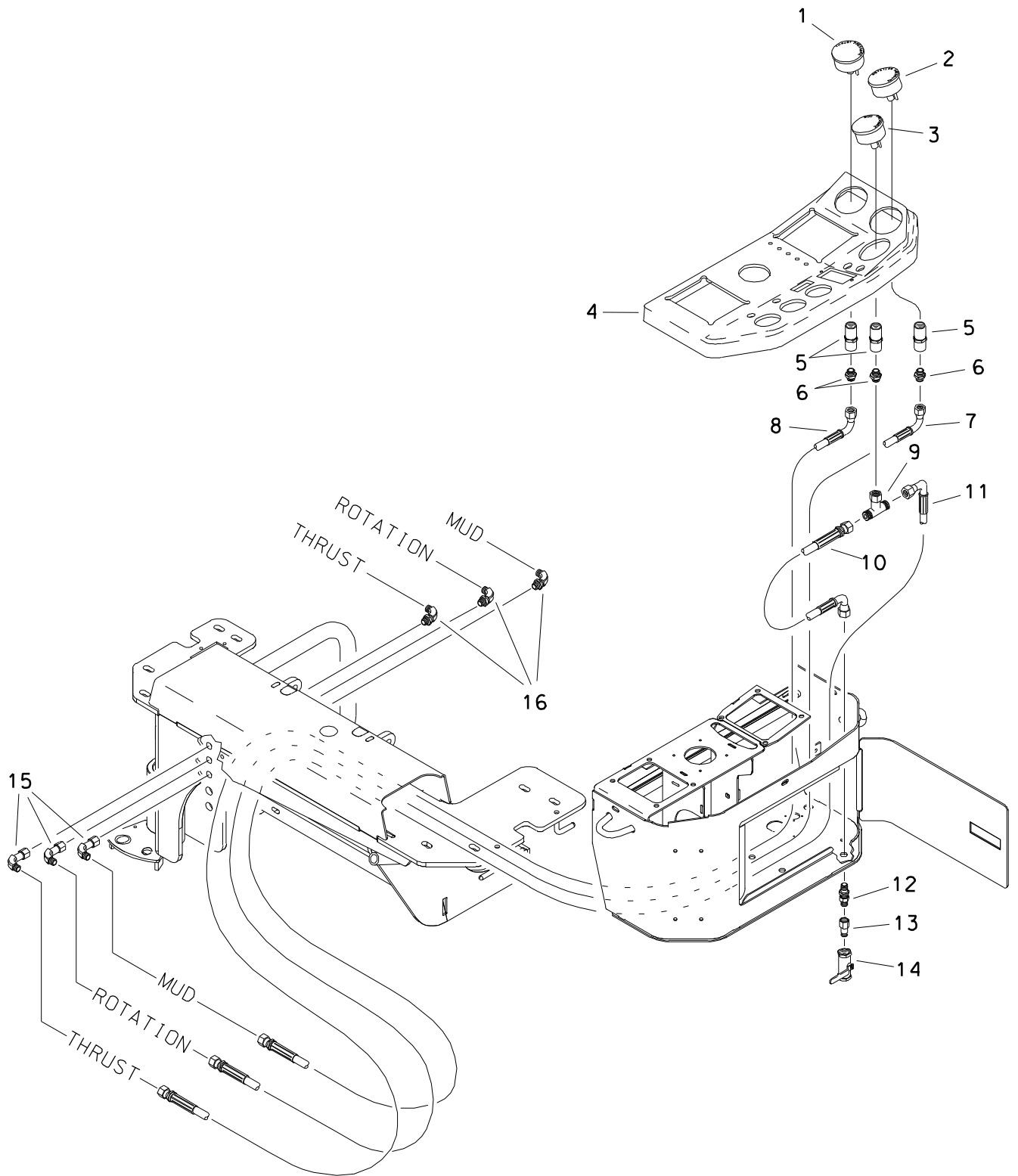

# RIGHT CONSOLE HYDRAULICS

REF NO.	PART NUMBER	QTY	DESCRIPTION	REMARKS
1.	258-045	1	GAUGE (4000 PSI)	(THRUST)
2.	258-036	1	HYD PRESSURE GAUGE (6000 PSI)	(ROTATION)
3.	258-046	1	PRESSURE GAUGE (1500PSI)	(MJD)
4.	211-014	-	RIGHT CONSOLE COVER	
5.	514-408	3	COLLAR (04NF)	
6.	154-339	3	CONNECTOR (04N-040)	
7.	515-667	1	HOSE (040FX90-54"-5000)	(ROTATION)
8.	154-900	1	HOSE (040FX90S-62"-3000)	(TRUST)
9.	154-379	1	UN BR TEE (040FX-040-040)	
10.	515-065	1	HOSE (040FX90S-14"-3000)	
11.	515-257	1	HOSE (040FX90S-54"-3000)	(MJD)
12.	153-238	1	BK CONNECTOR (040-06S)	
13.	153-264	1	REDUCER (04N-06SF)	
14.	120-071	1	SHUT-OFF (04NF-04NF)	
15.	154-255	3	UNION (040-040FX90)	
16.	154-355	3	BK CONNECTOR (040-04090BK)	

FOOTNOTES

# FRONT WRENCH PRESSURE & RETURN HYDRAULICS

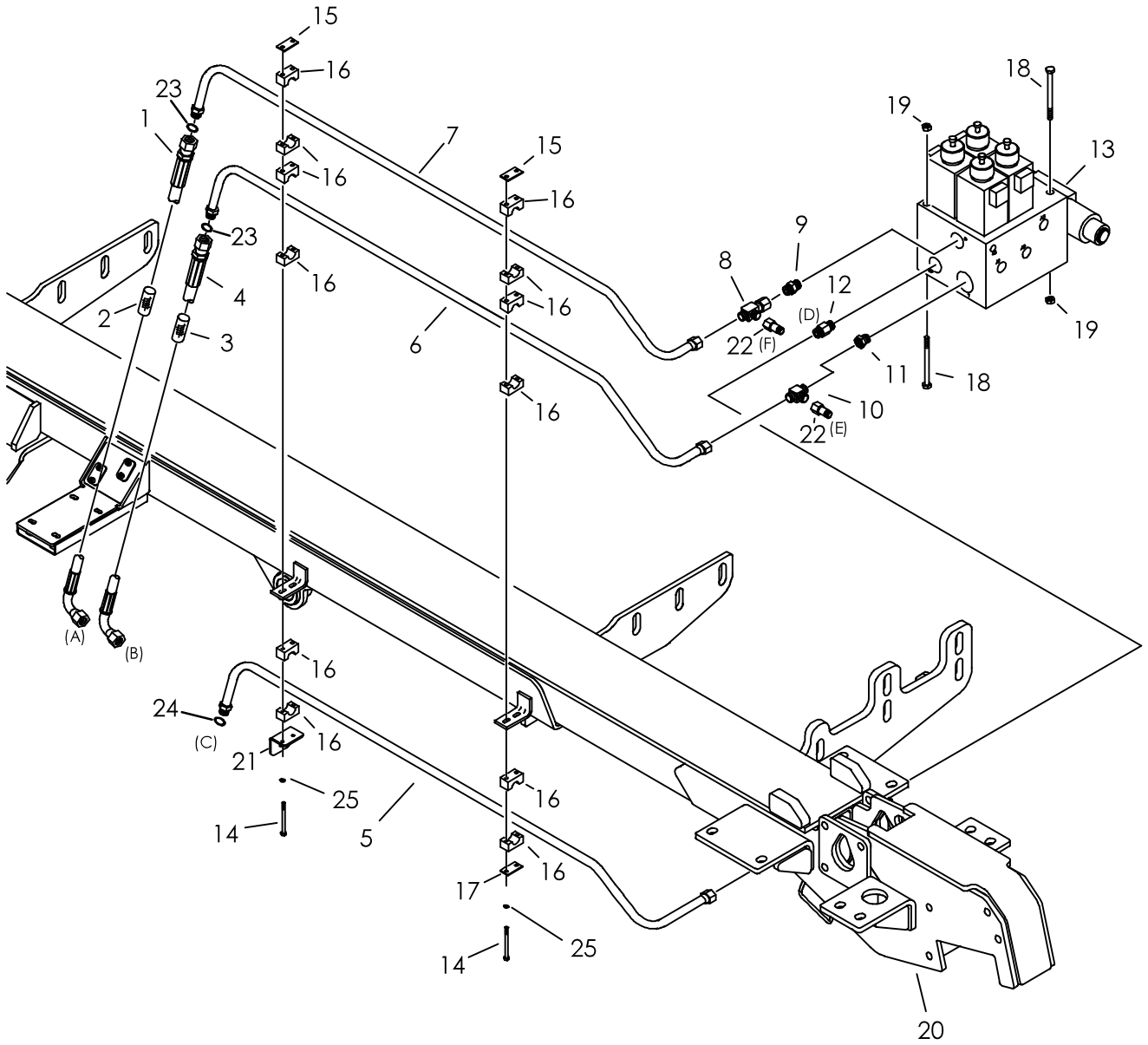

## FRONT WRENCH PRESSURE & RETURN HYDRAULICS

REF NO.	PART NUMBER	QTY	DESCRIPTION	REMARKS
1.	515-527	1	HOSE (100FX90-54"-3000)	
2.	117-657	1	ABRASION SLEEVE (1.59" X 54")	
3.	115-813	1	ABRASION SLEEVE (1.59" X 36")	
4.	515-498	1	HOSE (100FX90S-36"-3000)	
5.	149-532	1	HYDRAULIC LINE (-12)	
6.	149-531	1	HYDRAULIC LINE (-12)	
7.	149-530	1	HYDRAULIC LINE (-12)	
8.	154-368	1	UN RUN TEE (120FX-120-120)	
9.	154-269	1	CONNECTOR (12S-120)	
10.	154-292	1	RUN TEE (12S-120-120)	
11.	155-222	1	REDUCER (16S-12SF)	
12.	149-815	1	TEE (12S-120-040, SPECIAL)	
13.	149-258	-	HYDRAULIC VALVE	
	191-103	-	SEAL REPAIR KIT	FOR USE ON 499-311
	191-104	-	SEAL REPAIR KIT	FOR USE ON 501-872
	499-309	-	SOLENOID	REPLACEMENT FOR WRENCH ROTATE SECTION
	499-310	-	SOLENOID COIL	REPLACEMENT FOR WRENCH ROTATE SECTION
	499-311	-	SOLENOID CARTRIDGE	REPLACEMENT FOR THE FRONT AND REAR WRENCH SECTIONS
	499-312	-	SOLENOID COIL	REPLACEMENT FOR THE FRONT AND REAR WRENCH SECTIONS
	499-313	-	CHECK VALVE	LABELED CV1 AND CV2 ON VALVE BODY
	500-703	-	SEAL REPAIR KIT	FOR USE ON 499-313
	501-872	-	SHUTTLE VALVE	LABELED SV1, SV2 AND SV3 ON VALVE BODY
14.	108-078	4	BOLT (1/4-NC X 4-3/4", GD. 5)	
15.	322-290	2	MOUNT (WELD-ON)	
16.	110-411	6	BOLT-ON CLAMP (3/4", SET)	
17.	322-289	1	BACKUP (BOLT-ON)	
18.	107-420	3	SCREW (M10-1.50 X 140MM)	
19.	105-894	3	LOCKNUT(M10-1.50, PRV TRQ, 10.9)	
20.	303-648	-	DRILL FRAME WLDMN'T	
21.	309-891	1	BRACKET	
22.	154-441	2	REDUCER (100-120F)	
23.	157-040	2	O-RING (016 D90)	
24.	157-039	1	O-RING (014 D90)	
25.	106-076	16	WASHER (1/4")	

NOT SHOWN:

FOOTNOTES:

- (A) CONNECTS TO TEE IN PARKER THRUST VALVE PRESSURE INLET PORT
- (B) CONNECTS TO BRANCH TEE ON COOLER INLET TUBE
- (C) CONNECTS TO BULKHEAD RUN TEE ON TOP OF SUNSTRAND ROTATION PUMP
- (D) CONNECTS TO SOLENOID VALVE ON DRILL FRAME FOR CHARGE PRESSURE ON "OUTER ROTATION BRAKE HYDRAULICS"
- (E) CONNECTS TO TANK PORT ON ANCHOR VALVE IN PIVOT FRAME
- (F) CONNECTS TO PRESSURE PORT ON ANCHOR VALVE IN PIVOT FRAME

NOTE:

# FRONT WRENCH HYDRAULICS

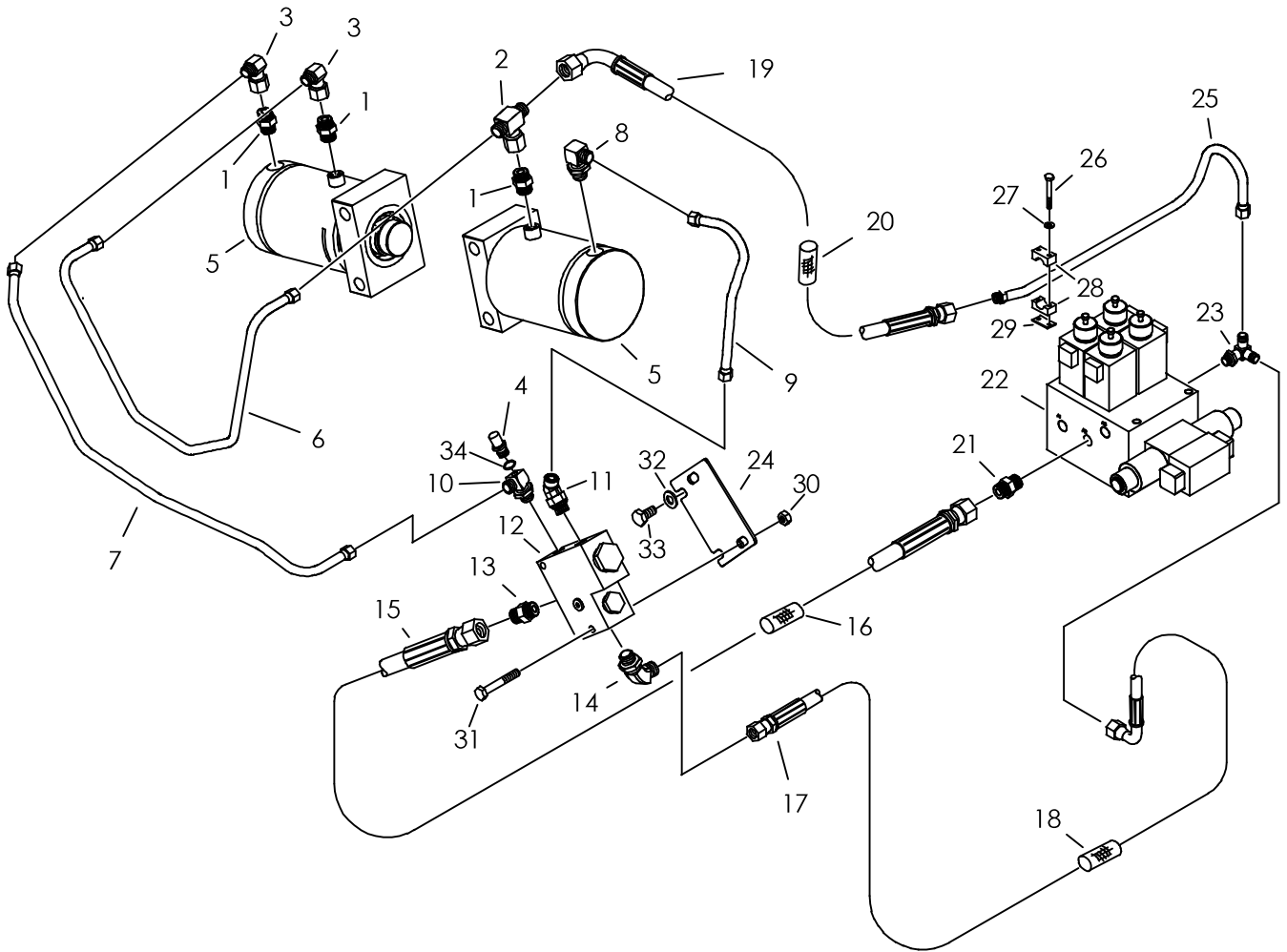



## FRONT WRENCH HYDRAULICS

REF NO.	PART NUMBER	QTY	DESCRIPTION	REMARKS
1.	154-246	3	CONNECTOR (06S-080)	
2.	154-257	1	UN BR TEE (080FX-080-080)	
3.	154-256	2	UNION (080-080FX90)	
4.	214-645	1	PRESSURE SWITCH (500PSI)	
5.	151-206	2	CYL (4.50" X 2.25" X 2.75")	
6.	149-500	1	HYD LINE	
7.	149-650	1	HYDRAULIC LINE (-08)	
8.	154-253	1	CONNECTOR (06S-08090)	
9.	149-649	1	HYDRAULIC LINE (-08)	
10.	149-572	1	SPECIAL TEE (08S-06SF-080)	
11.	154-284	1	CONNECTOR (08S-08045)	
12.	149-791	1	HYDRAULIC VALVE	USE SERVICE PARTS: 500-2041 SEAL KIT & 500-2042 SEAL
13.	154-279	1	CONNECTOR (080-10S)	
14.	154-226	1	CONNECTOR (040-06S90)	
15.	154-721	1	HOSE (080FX-28"-3000)	
16.	117-396	1	ABRASION SLEEVE (1.25" X 28")	
17.	154-705	1	HOSE (040FX90-60"-3000)	
18.	117-693	1	ABRASION SLEEVE (1.00" X 60")	
19.	154-838	1	HOSE (080FX90-44"-3000)	
20.	117-189	1	ABRASION SLEEVE (1.25" X 44")	
21.	154-233	1	CONNECTOR (08S-080)	
22.	149-258	1	HYDRAULIC VALVE	
23.	514-160	1	BRANCH TEE (08S-080-040)	
24.	310-910	1	PLATE	
25.	149-529	1	HYDRAULIC LINE (-08)	
26.	105-106	2	BOLT (1/4-NC X 2")	
27.	106-076	2	WASHER (1/4")	
28.	110-866	1	CLAMP (1/2")	
29.	110-783	1	WELD PLATE	
30.	107-661	2	FLG LKNUT (M10-1.50 PRE TRQ)	
31.	106-142	2	SCREW (M10-1.50 X 65MM)	
32.	106-397	2	WASHER (M12, HARDENED)	
33.	107-521	2	SCREW (M12-1.75 X 20MM)	
34.	155-705	1	O-RING (906 D90)	

NOT SHOWN:

FOOTNOTES:

**NOTE:**

REFER TO O-RING CHART (800-301) IN BACK OF THE BOOK FOR REPLACEMENT OF O-RINGS.

# REAR WRENCH

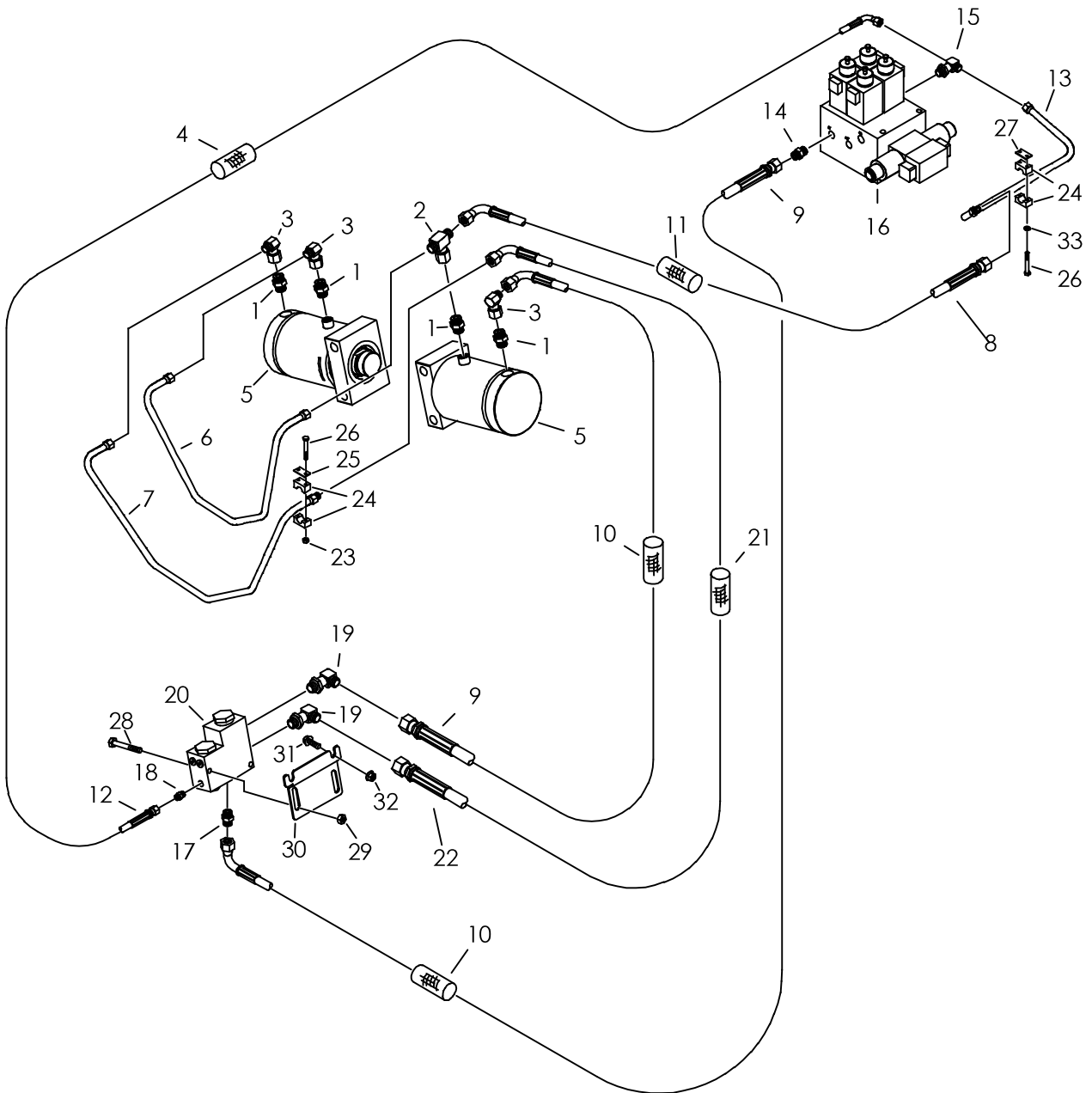

## REAR WRENCH

REF NO.	PART NUMBER	QTY	DESCRIPTION	REMARKS
1.	154-246	1	CONNECTOR (06S-080)	
2.	154-257	1	UN BR TEE (080FX-080-080)	
3.	154-256	3	UNION (080-080FX90)	
4.	117-387	1	ABRASION SLEEVE (1.00" X 42")	
5.	151-206	2	CYL (4.50" X 2.25" X 2.75")	
6.	149-500	1	HYD LINE	
7.	149-498	1	HYDRAULIC LINE (-08)	
8.	153-300	1	HOSE (080FX90M-44"-3000)	
9.	154-837	2	HOSE (080FX90S-34"-3000)	
10.	117-397	2	ABRASION SLEEVE (1.25" X 35")	
11.	117-189	1	ABRASION SLEEVE (1.25" X 44")	
12.	153-298	1	HOSE (040FX90L-42"-3000)	
13.	149-528	1	HYDRAULIC LINE (-08)	
14.	154-233	1	CONNECTOR (08S-080)	
15.	153-262	1	SPECIAL TEE (040-080-08S)	
16.	149-258	1	HYDRAULIC VALVE	
17.	154-279	1	CONNECTOR (080-10S)	
18.	154-220	1	CONNECTOR (040-06S)	
19.	154-254	2	CONNECTOR (08S-08090, XL)	
20.	149-791	1	HYDRAULIC VALVE	USE SERVICE PARTS: 500-2041 SEAL KIT & 500-2042 SEAL
21.	117-214	1	ABRASION SLEEVE (1.25" X 40")	
22.	515-025	1	HOSE (080FX90-40"-3000)	
23.	105-085	2	LOCKNUT (1/4-NC)	
24.	110-866	2	CLAMP (1/2")	
25.	110-958	1	BACKUP PLATE	
26.	105-198	4	BOLT (1/4-NC X 1-3/4")	
27.	110-783	1	WELD PLATE	
28.	106-142	2	SCREW (M10-1.50 X 65MM)	
29.	107-661	2	FLG LKNUT (M10-1.50 PRE TRQ)	
30.	307-723	1	MOUNTING PLATE	
31.	106-724	2	FLG SCREW (M10-1.50 X 25MM)	
32.	106-387	2	FLG LOCKNUT (M10-1.50)	
33.	106-076	2	WASHER (1/4")	

NOT SHOWN:

FOOTNOTES:

**NOTE:**

REFER TO O-RING CHART (800-301) IN BACK OF THE BOOK FOR REPLACEMENT OF O-RINGS.

## WRENCH ROTATE HYDRAULICS

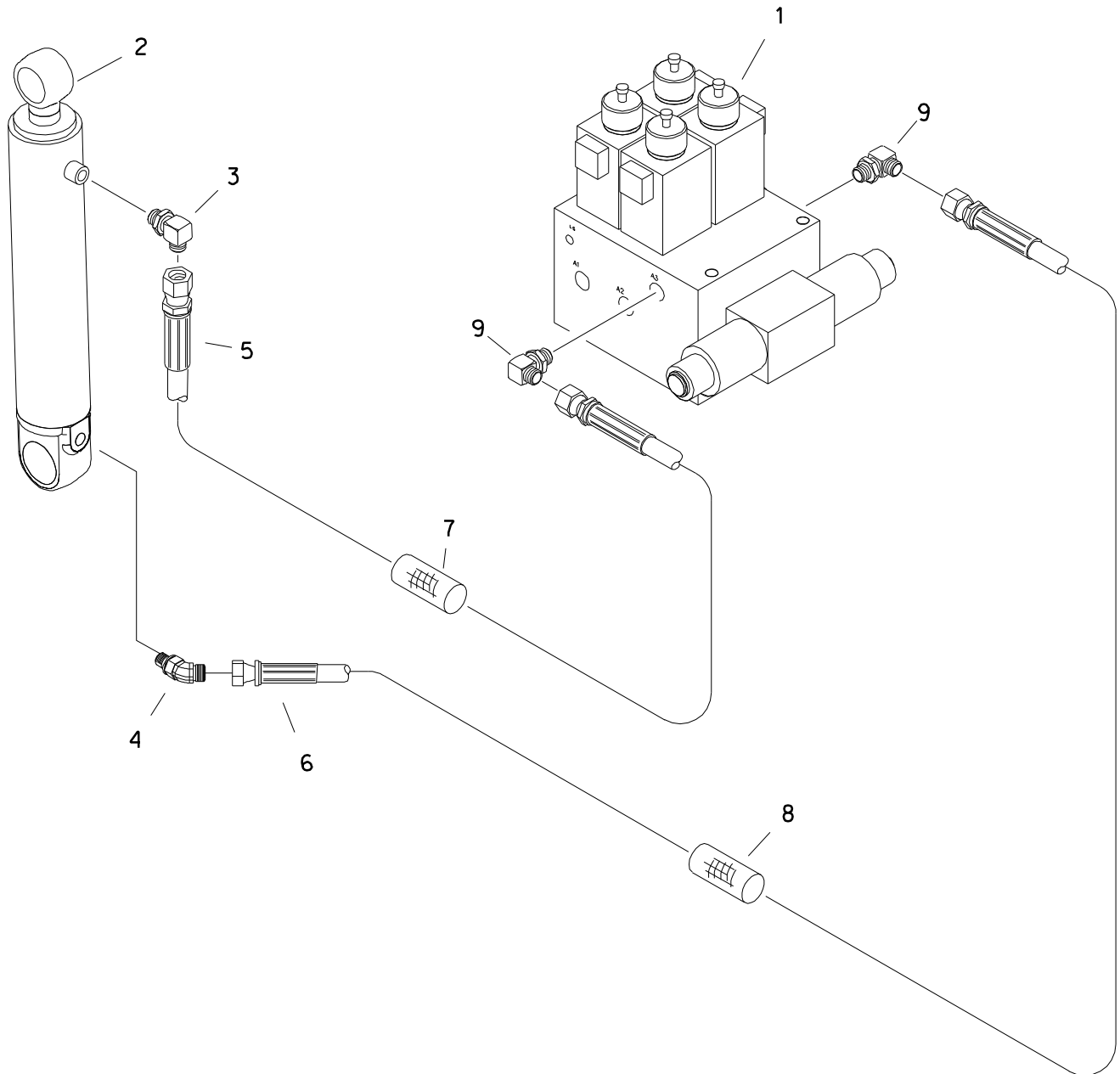

# WRENCH ROTATE HYDRAULICS

REF NO.	PART NUMBER	QTY	DESCRIPTION	REMARKS
1.	149-258	1	HYDRAULIC VALVE	
2.	151-031	-	CYL (2.0" X 1.0" X 8.0")	
3.	514-049	1	CONNECTOR (04S-06090)	
4.	514-414	1	CONNECTOR (04S-06045)	
5.	154-755	1	HOSE (060FX-34"-3000)	
6.	154-722	1	HOSE (060FX-32"-3000)	
7.	117-412	1	ABRASION SLEEVE (1.00" X 34")	
8.	117-411	1	ABRASION SLEEVE (1.00" X 32")	
9.	154-227	2	CONNECTOR (06Q-08S90)	

FOOTNOTES

# PIPE GRIPPER HYDRAULICS

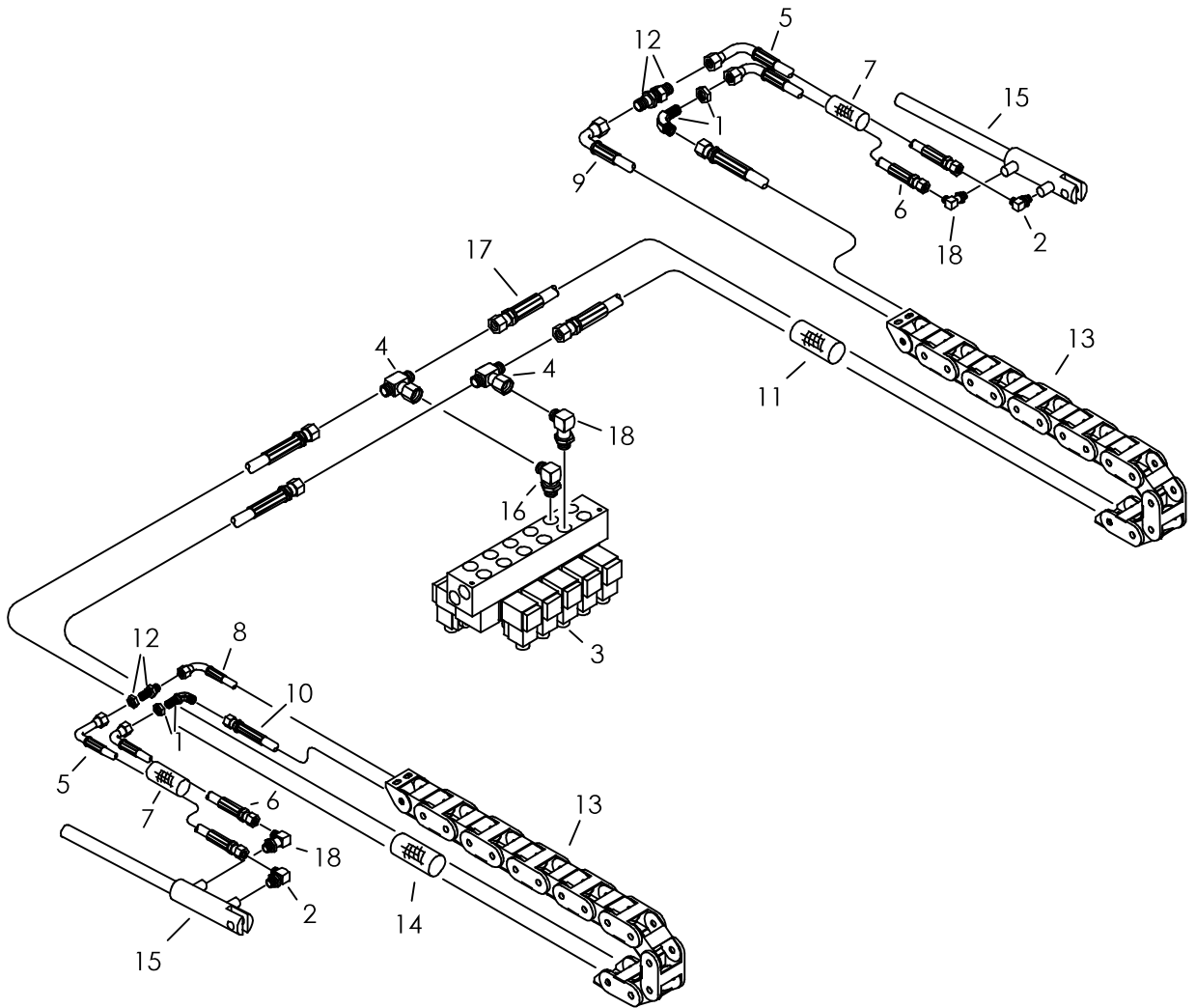

## PIPE GRIPPER HYDRAULICS

REF NO.	PART NUMBER	QTY	DESCRIPTION	REMARKS
1.	154-355	2	BK CONNECTOR (04O-04O90BK)	
2.	154-252	2	CONNECTOR (04S-04O90)	
3.	153-095	-	HYDRAULIC CONTROL VALVE	
4.	154-379	2	UN BR TEE (04OFX-04O-04O)	
5.	153-309	2	HOSE (04OFX90S-10.5"-3000)	
6.	153-308	2	HOSE (04OFX90L-14"-3000)	
7.	117-415	2	ABRASION SLEEVE (1.59" X 10")	
8.	515-030	1	HOSE (04OFX90S-64"-3000)	
9.	154-729	1	HOSE (04OFX90-44"-3000)	
10.	515-440	1	HOSE (04OFX-64"-3000)	
11.	117-214	1	ABRASION SLEEVE (1.25" X 40")	
12.	154-275	2	BK CONNECTOR (04O-04OBK)	
13.	306-746	-	HOSE TRACK	
14.	117-392	1	ABRASION SLEEVE (1.25" X 60")	
15.	191-161	2	GRIPPER CYLINDER	
16.	154-401	1	CONNECTOR (04S-04O90, ORF)	
17.	154-693	1	HOSE (04OFX-44"-3000)	
18.	154-474	3	CONNECTOR (04S-04O90, XL)	

### FOOTNOTES

### NOTE:

REFER TO O-RING CHART (800-301) IN BACK OF THE BOOK FOR REPLACEMENT OF O-RINGS.

# PIPE GRIPPER HYDRAULICS

BEGINS WITH S/N 2V1091

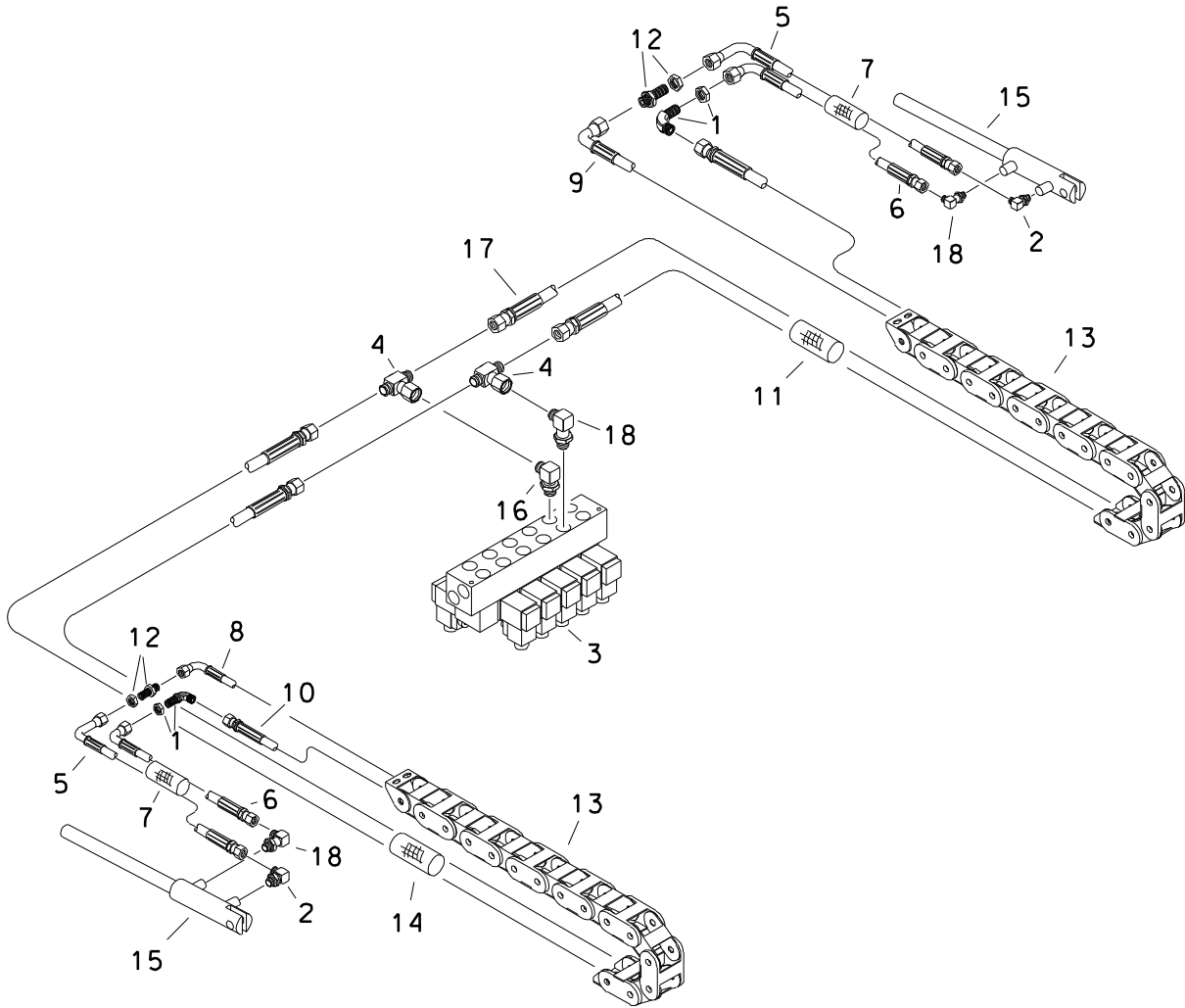



# PIPE GRIPPER HYDRAULICS

## BEGINS WITH S/N 2V1091

REF NO.	PART NUMBER	QTY	DESCRIPTION	REMARKS
1.	154-355	2	BK CONNECTOR (040-04090BK)	
2.	154-252	2	CONNECTOR (04S-04090)	
3.	153-095	-	HYD VALVE	
4.	154-379	2	UN BR TEE (040FX-040-040)	
5.	515-599	2	HOSE (040FX90-13"-3000)	
6.	515-148	2	HOSE (040FX90-10"-3000)	
7.	117-415	2	ABRASION SLEEVE (1.59" X 10")	
8.	515-030	1	HOSE (040FX90-64"-3000)	
9.	154-729	1	HOSE (040FX90-44"-3000)	
10.	515-440	1	HOSE (040FX-64"-3000)	
11.	117-214	1	ABRASION SLEEVE (1.25" X 40")	
12.	154-275	2	BK CONNECTOR (040-040BK)	
13.	306-746	-	HOSE TRACK	
14.	117-392	1	ABRASION SLEEVE (1.25" X 60")	
15.	149-062	2	CYL ( )	
16.	154-401	1	CONNECTOR (04S-04090, ORF)	
17.	154-693	1	HOSE (040FX-44"-3000)	
18.	154-474	3	CONNECTOR (04S-04090, XL)	

FOOTNOTES

NOTE:  
REFER TO O-RING CHART (800-301) IN BACK OF THE BOOK FOR REPLACEMENT OF O-RINGS.

## STABILIZER HYDRAULICS

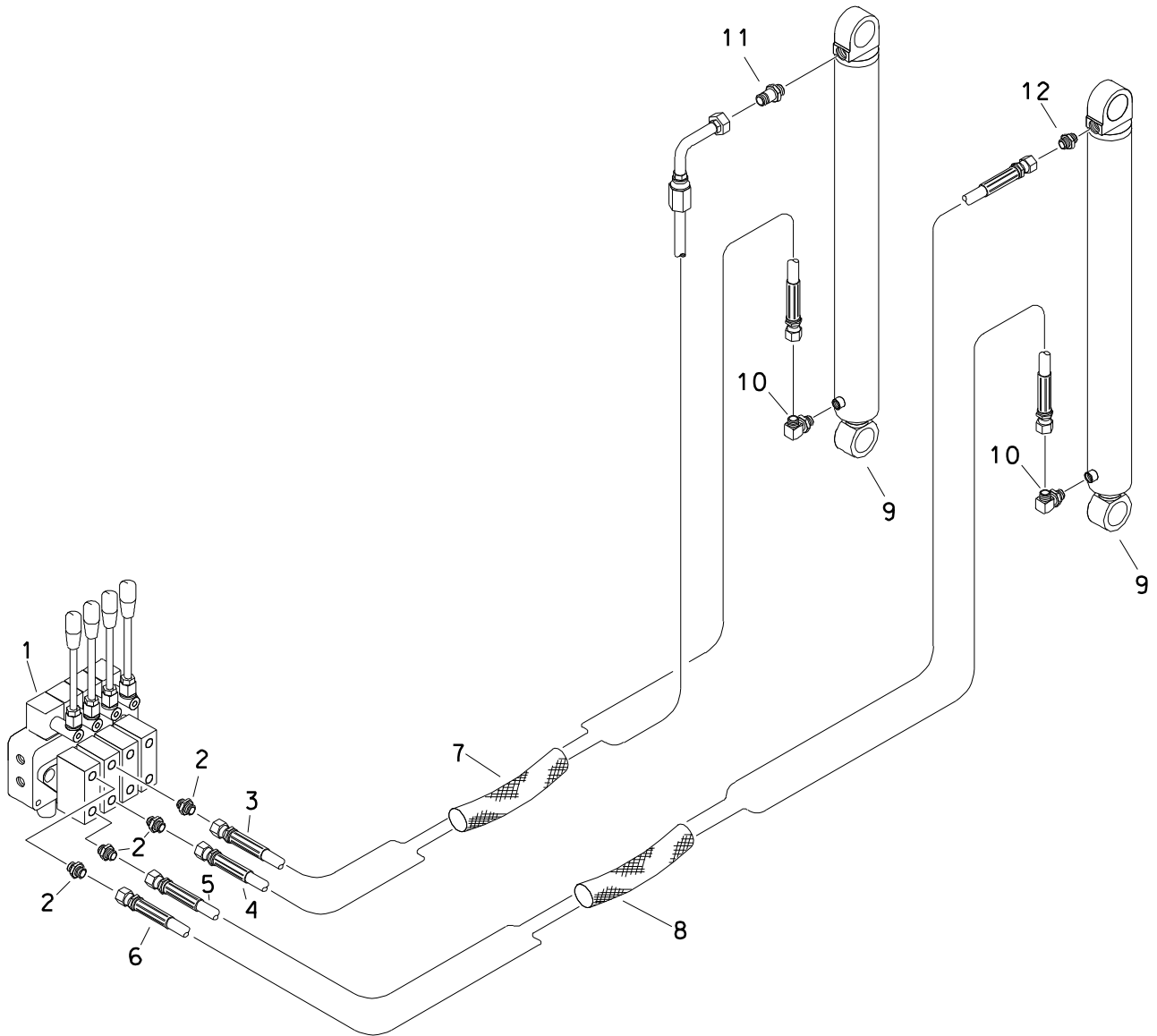

# STABILIZER HYDRAULICS

REF NO.	PART NUMBER	QTY	DESCRIPTION	REMARKS
1.	149-077	1	HYD CONTROL VALVE (4-SPOOL)	
	365-426	4	LEVER (M8-1.25 X 200mm)	
2.	154-385	4	CONNECTOR (040-06S, ORF)	
3.	154-651	1	HOSE (040FX-66"-3000)	
4.	515-753	1	HOSE (040FX90L-44"-3000)	
5.	154-966	1	HOSE (040FX-95"-3000)	
6.	154-811	1	HOSE (040FX-116"-3000)	
7.	115-737	1	ABRASION SLEEVE (1.59" X 40")	
8.	115-924	1	ABRASION SLEEVE (1.59" X 88")	
9.	151-065	2	CYL (2" X 1.25" X 20")	
10.	154-252	2	CONNECTOR (04S-04090)	
11.	154-403	1	CONNECTOR (04S-040, XL)	
12.	154-278	1	CONNECTOR (04S-040)	

FOOTNOTES

NOTE:  
REFER TO O-RING CHART (800-3001 IN THE PACK OF THE BOOK FOR REPLACEMENT OF O-RINGS.

# DRILL FRAME PIVOT HYDRAULICS

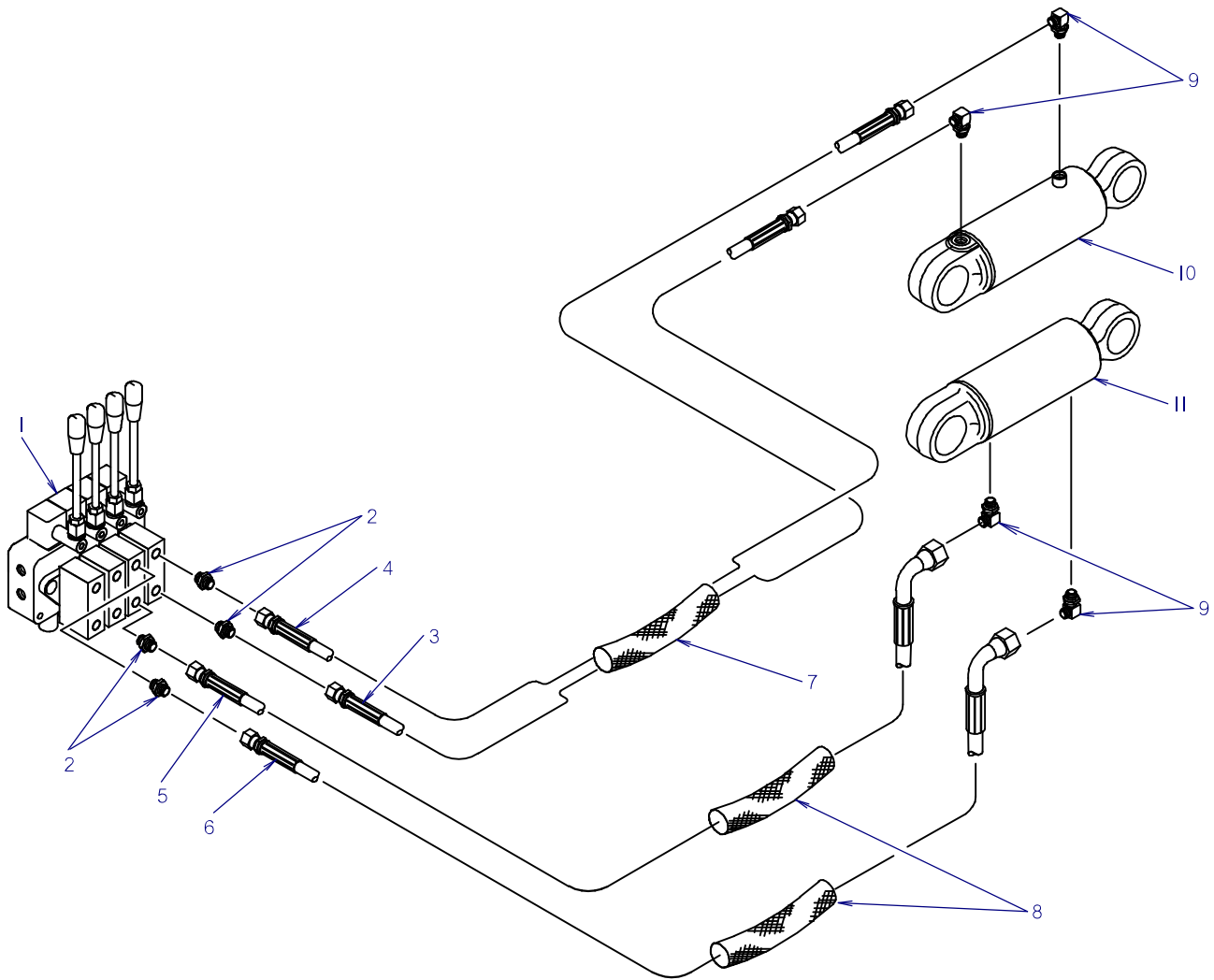

## DRILL FRAME PIVOT HYDRAULICS

REF NO.	PART NUMBER	QTY	DESCRIPTION	REMARKS
1.	149-077	1	HYD CONTROL VALVE (4-SPOOL)	
	365-426	-	LEVER (M8-1.25 X 200MM)	
2.	510-015	4	ADAPTER (06S-060, ORF)	
3.	154-758	1	HOSE (060FX-90"-3000)	
4.	154-757	1	HOSE (060FX-86"-3000)	
5.	515-714	1	HOSE (06FX90-82"-3000)	
6.	515-715	1	HOSE (06FX90-86"-3000)	
7.	115-817	1	ABRASION SLEEVE (1.59" X 66")	
8.	115-963	2	ABRASION SLEEVE (1.59" X 60")	
9.	154-227	4	CONNECTOR (060-08S90)	
10.	151-066	1	CYL (4.0" X 2.0" X 5.0")	
11.	149-698	1	CYLINDER ASSEMBLY	

NOT SHOWN:

FOOTNOTES:

NOTE:

REFER TO O-RING CHART (800-301) IN BACK OF THE BOOK FOR REPLACEMENT OF O-RINGS.

# HYDRAULIC CYLINDERS (2.0" X 1.0")

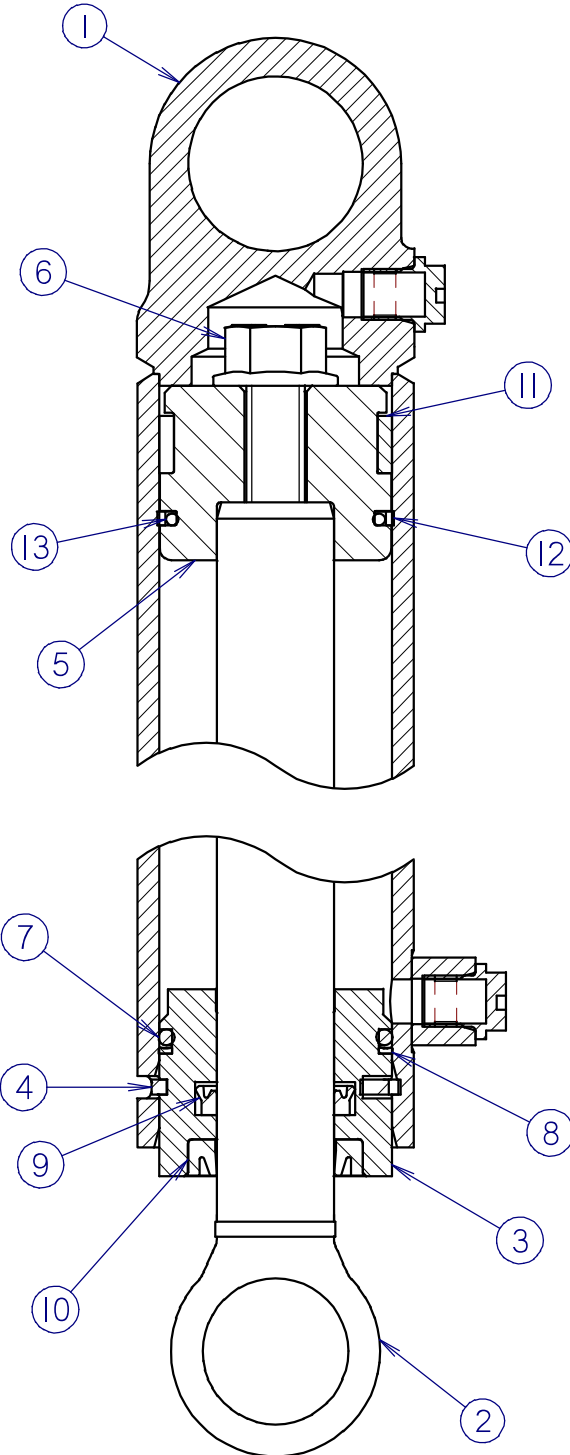

## HYDRAULIC CYLINDERS (2.0" X 1.0")

REF NO.	PART NUMBER	QTY	DESCRIPTION	REMARKS
	151-094	-	CYL (2.0 X 1.0 X 2.0)	SEE FOOTNOTES 1 & 2
1	152-029	1	CYLINDER BARREL (2.0 X 2.0)	
2	153-007	1	CYLINDER ROD (1.00 X 2.0)	
	149-667	-	CYL (2.0 X 1.0 X 2.5)	SEE FOOTNOTES 1 & 2
1	149-761	1	CYLINDER BARREL (2.0 X 2.5)	
2	149-728	1	CYLINDER ROD (1.00 X 2.5)	
	151-027	-	CYL (2.0 X 1.0 X 3.0)	SEE FOOTNOTES 1 & 2
1	150-282	1	CYLINDER BARREL (2.0 X 3.0)	
2	150-414	1	CYLINDER ROD (1.00 X 3.0)	
	151-038	-	CYL (2.0 X 1.0 X 4.0)	SEE FOOTNOTES 1 & 2
1	150-290	1	CYLINDER BARREL (2.0 X 4.0)	
2	150-421	1	CYLINDER ROD (1.00 X 4.0)	
	151-039	-	CYL (2.0 X 1.0 X 5.0)	SEE FOOTNOTES 1 & 2
1	150-291	1	CYLINDER BARREL (2.0 X 5.0)	
2	150-422	1	CYLINDER ROD (1.00 X 5.0)	
	151-044	-	CYL (2.0 X 1.0 X 6.0)	SEE FOOTNOTES 1 & 2
1	150-294	1	CYLINDER BARREL (2.0 X 6.0)	
2	150-424	1	CYLINDER ROD (1.00 X 6.0)	
	151-031	-	CYL (2.0 X 1.0 X 8.0)	SEE FOOTNOTES 1 & 2
1	150-285	1	CYLINDER BARREL (2.0 X 8.0)	
2	150-417	1	CYLINDER ROD (1.00 X 8.0)	
	151-076	-	CYL (2.0 X 1.0 X 10.0)	SEE FOOTNOTES 1 & 2
1	152-017	1	CYLINDER BARREL (2.0 X 10.0)	
2	150-444	1	CYLINDER ROD (1.00 X 10.0)	
	149-668	-	CYL (2.0 X 1.0 X 12.0)	SEE FOOTNOTES 1 & 2
1	150-286	1	CYLINDER BARREL (2.0 X 12.0)	
2	149-729	1	CYLINDER ROD (1.00 X 12.0)	
3	150-772	1	CYLINDER HEAD (2.0 X 1.00)	
4	150-778	1	LOCK RING (2.0)	
5	150-775	1	CYLINDER PISTON (2.0 X 1.00)	
6	106-096	1	FLG BOLT (1/2-NC X 1-3/4",GD8)	SEE FOOTNOTE 3
7	157-022	1	O-RING (224 D90)	
8	155-732	1	BACKUP RING (224 D90)	
9	157-540	1	U-SEAL (1.000")	
10	157-537	1	WIPER SEAL (1.000")	
11	125-774	1	WEAR RING	
12	157-534	1	BACKUP RING (131 D90)	
13	157-018	1	O-RING (131 D90)	

**NOT SHOWN:**

259-100	U-SEAL INSTALLER (1" - 1.499")
259-235	1.00 ROD WIPER TOOL
259-239	WIPER/SEAL INSTALLER (2")
259-241	PISTON INSTALLER (2")
259-188	CYL HEAD SPANNER - TWO PIN

**FOOTNOTES:**

- REF. #1 & #2 ARE SPECIFIC TO EACH CYLINDER, REF. #3 THRU #13 ARE COMMON FOR ALL THE ABOVE LISTED CYLINDERS
- SEAL REPAIR KIT P/N: 190-165
- APPLY LOCTITE 277 OR EQUIVALENT, TORQUE TO 90-100 FT-LBS

**NOTE:**

# HYDRAULIC CYLINDERS (2.0" X 1.25")

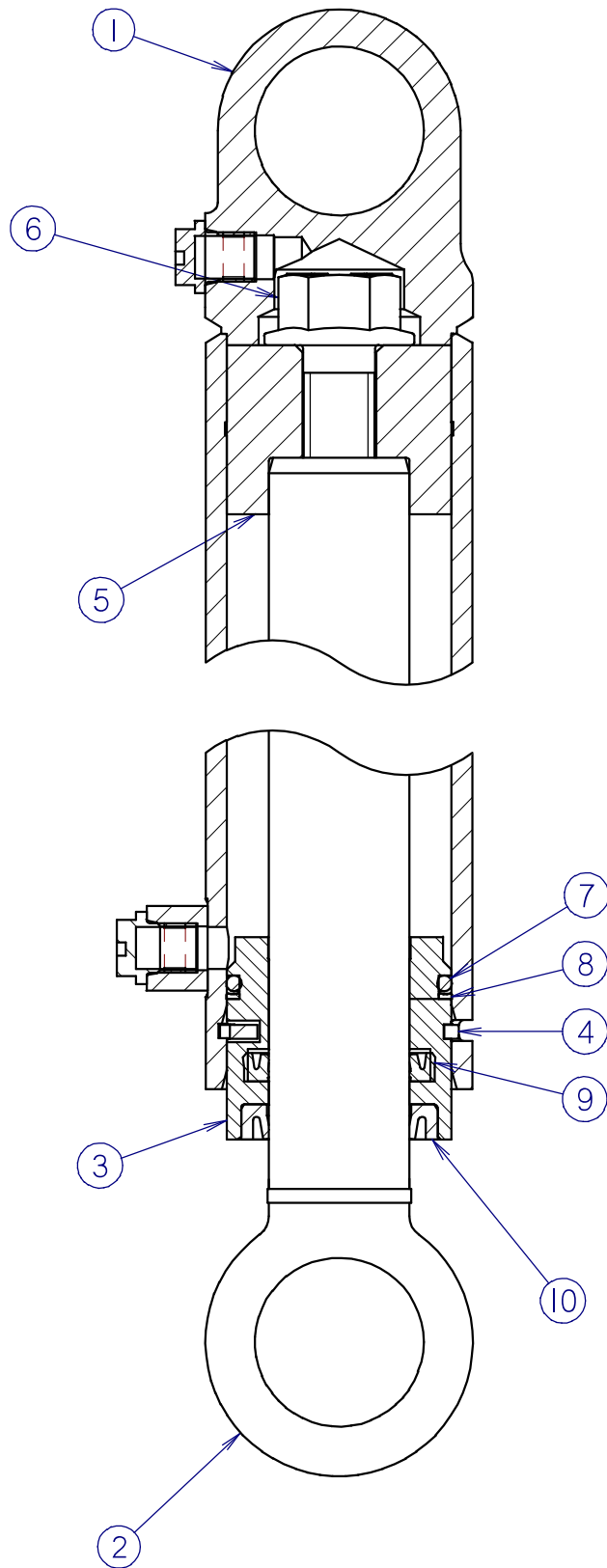



## HYDRAULIC CYLINDERS (2.0" X 1.25")

REF NO.	PART NUMBER	QTY	DESCRIPTION	REMARKS
	149-669	-	CYL (2.0 X 1.25 X 2.0)	SEE FOOTNOTES 1 & 2
1	152-029	1	CYLINDER BARREL (2.0 X 2.0)	
2	153-012	1	CYLINDER ROD (1.25 X 2.0)	
	149-670	-	CYL (2.0 X 1.25 X 2.5)	SEE FOOTNOTES 1 & 2
1	149-761	1	CYLINDER BARREL (2.0 X 2.5)	
2	153-005	1	CYLINDER ROD (1.25 X 2.5)	
	149-671	-	CYL (2.0 X 1.25 X 3.0)	SEE FOOTNOTES 1 & 2
1	150-282	1	CYLINDER BARREL (2.0 X 3.0)	
2	150-435	1	CYLINDER ROD (1.25 X 3.0)	
	149-672	-	CYL (2.0 X 1.25 X 4.0)	SEE FOOTNOTES 1 & 2
1	150-290	1	CYLINDER BARREL (2.0 X 4.0)	
2	150-415	1	CYLINDER ROD (1.25 X 4.0)	
	151-060	-	CYL (2.0 X 1.25 X 5.0)	SEE FOOTNOTES 1 & 2
1	150-291	1	CYLINDER BARREL (2.0 X 5.0)	
2	150-423	1	CYLINDER ROD (1.25 X 5.0)	
	149-673	-	CYL (2.0 X 1.25 X 6.0)	SEE FOOTNOTES 1 & 2
1	150-294	1	CYLINDER BARREL (2.0 X 6.0)	
2	150-438	1	CYLINDER ROD (1.25 X 6.0)	
	151-057	-	CYL (2.0 X 1.25 X 8.0)	SEE FOOTNOTES 1 & 2
1	150-285	1	CYLINDER BARREL (2.0 X 8.0)	
2	150-427	1	CYLINDER ROD (1.25 X 8.0)	
	149-674	-	CYL (2.0 X 1.25 X 10.0)	SEE FOOTNOTES 1 & 2
1	152-017	1	CYLINDER BARREL (2.0 X 10.0)	
2	149-730	1	CYLINDER ROD (1.25 X 10.0)	
	151-032	-	CYL (2.0 X 1.25 X 12.0)	SEE FOOTNOTES 1 & 2
1	150-286	1	CYLINDER BARREL (2.0 X 12.0)	
2	150-418	1	CYLINDER ROD (1.25 X 12.0)	
	151-091	-	CYL (2.0 X 1.25 X 16.0)	SEE FOOTNOTES 1 & 2
1	152-027	1	CYLINDER BARREL (2.0 X 16.0)	
2	150-448	1	CYLINDER ROD (1.25 X 16.0)	
	151-065	-	CYL (2.0 X 1.25 X 20.0)	SEE FOOTNOTES 1 & 2
1	152-011	1	CYLINDER BARREL (2.0 X 20.0)	
2	150-439	1	CYLINDER ROD (1.25 X 20.0)	
3	150-770	1	CYLINDER HEAD (2.0 X 1.25)	
4	150-778	1	LOCK RING (2.0)	
5	150-771	1	CYLINDER PISTON (2.0 X 1.25)	INCL MOLDED-ON WEAR RING
6	106-097	1	FLG BOLT (5/8-NC X 1-3/4",GD8)	SEE FOOTNOTE 3
7	157-022	1	O-RING (224 D90)	
8	155-732	1	BACKUP RING (224 D90)	
9	157-541	1	U-SEAL (1.250")	
10	157-538	1	WIPER SEAL (1.250")	

**NOT SHOWN:**

259-100	U-SEAL INSTALLER (1" - 1.499")
259-236	WIPER INSTALLER (1.25")
259-239	WIPER/SEAL INSTALLER (2")
259-241	PISTON INSTALLER (2")
259-188	CYL HEAD SPANNER - TWO PIN

**FOOTNOTES:**

- REF. #1 & #2 ARE SPECIFIC TO EACH CYLINDER, REF. #3 THRU #10 ARE COMMON FOR ALL THE ABOVE LISTED CYLINDERS.
- SEAL KIT P/N 190-169
- APPLY LOCTITE 277 OR EQUIVALENT, TORQUE TO 180-200 FT-LBS

**NOTE:**

# HYDRAULIC CYLINDERS (4.0" X 2.0")

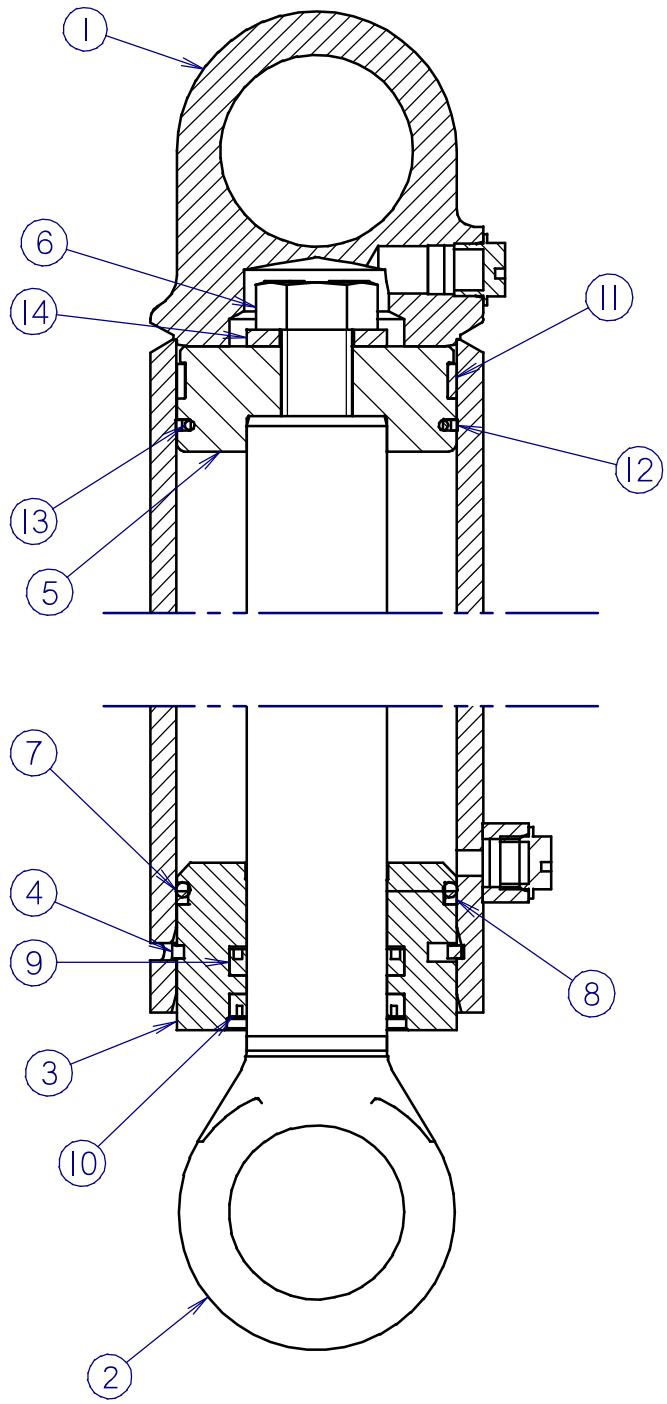

## HYDRAULIC CYLINDERS (4.0" X 2.0")

REF NO.	PART NUMBER	QTY	DESCRIPTION	REMARKS
	149-698	-	CYL (4.0 X 2.0 X 4.0)	SEE FOOTNOTES 1 & 2
1	149-768	1	CYLINDER BARREL (4.0 X 4.0)	
2	153-021	1	CYLINDER ROD (2.00 X 4.0)	
	151-066	-	CYL (4.0 X 2.0 X 5.0)	SEE FOOTNOTES 1 & 2
1	152-012	1	CYLINDER BARREL (4.0 X 5.0)	
2	150-440	1	CYLINDER ROD (2.00 X 5.0)	
	149-699	-	CYL (4.0 X 2.0 X 6.0)	SEE FOOTNOTES 1 & 2
1	152-062	1	CYLINDER BARREL (4.0 X 6.0)	
2	149-735	1	CYLINDER ROD (2.00 X 6.0)	
	149-700	-	CYL (4.0 X 2.0 X 8.0)	SEE FOOTNOTES 1 & 2
1	152-030	1	CYLINDER BARREL (4.0 X 8.0)	
2	149-736	1	CYLINDER ROD (2.00 X 8.0)	
	149-701	-	CYL (4.0 X 2.0 X 10.0)	SEE FOOTNOTES 1 & 2
1	149-769	1	CYLINDER BARREL (4.0 X 10.0)	
2	153-016	1	CYLINDER ROD (2.00 X 10.0)	
	151-088	-	CYL (4.0 X 2.0 X 12.0)	SEE FOOTNOTES 1 & 2
1	150-298	1	CYLINDER BARREL (4.0 X 12.0)	
2	150-429	1	CYLINDER ROD (2.00 X 12.0)	
	149-702	-	CYL (4.0 X 2.0 X 16.0)	SEE FOOTNOTES 1 & 2
1	152-007	1	CYLINDER BARREL (4.0 X 16.0)	
2	149-737	1	CYLINDER ROD (2.00 X 16.0)	
	149-703	-	CYL (4.0 X 2.0 X 20.0)	SEE FOOTNOTES 1 & 2
1	149-770	1	CYLINDER BARREL (4.0 X 20.0)	
2	149-738	1	CYLINDER ROD (2.00 X 20.0)	
	149-704	-	CYL (4.0 X 2.0 X 24.0)	SEE FOOTNOTES 1 & 2
1	152-063	1	CYLINDER BARREL (4.0 X 24.0)	
2	149-739	1	CYLINDER ROD (2.00 X 24.0)	
3	149-006	1	CYLINDER HEAD (4.0 X 2.00)	
4	149-303	1	LOCK RING (4.0)	
5	149-307	1	CYLINDER PISTON (4.0 X 2.00)	
6	106-145	1	BOLT (1-NC X 2-1/4", GD8)	SEE FOOTNOTE 3
7	157-035	1	O-RING (342 D90)	
8	157-036	1	BACKUP RING (342 D90)	
9	157-559	1	U-SEAL (2.000")	
10	157-558	1	WIPER SEAL (2.000")	
11	125-793	1	WEAR RING	
12	157-570	1	BACKUP RING (238 D90)	
13	157-044	1	O-RING (238 D90)	
14	106-144	1	WASHER (1")	

### FOOTNOTES

- REF. #1 & #2 ARE SPECIFIC TO EACH CYLINDER, REF. #3 THRU #14 ARE COMMON FOR ALL THE ABOVE LISTED CYLINDERS.
- SEAL REPAIR KIT P/N: 190-189
- APPLY LOCTITE 277 OR EQUIVALENT, TORQUE TO 630-700 FT-LBS

### NOT SHOWN:

- 259-040 U-SEAL INSTALLER (1.5" - UP)
- 259-239 WIPER/SEAL INSTALLER (2")
- 259-246 PISTON SEAL INSTALLER (4")
- 259-247 PISTON INSTALLER (4")
- 259-188 CYL HEAD SPANNER - TWO PIN

A

809-369

# HYDRAULIC CYLINDER CYLINDER (4.50" X 2.25" X 2.75")

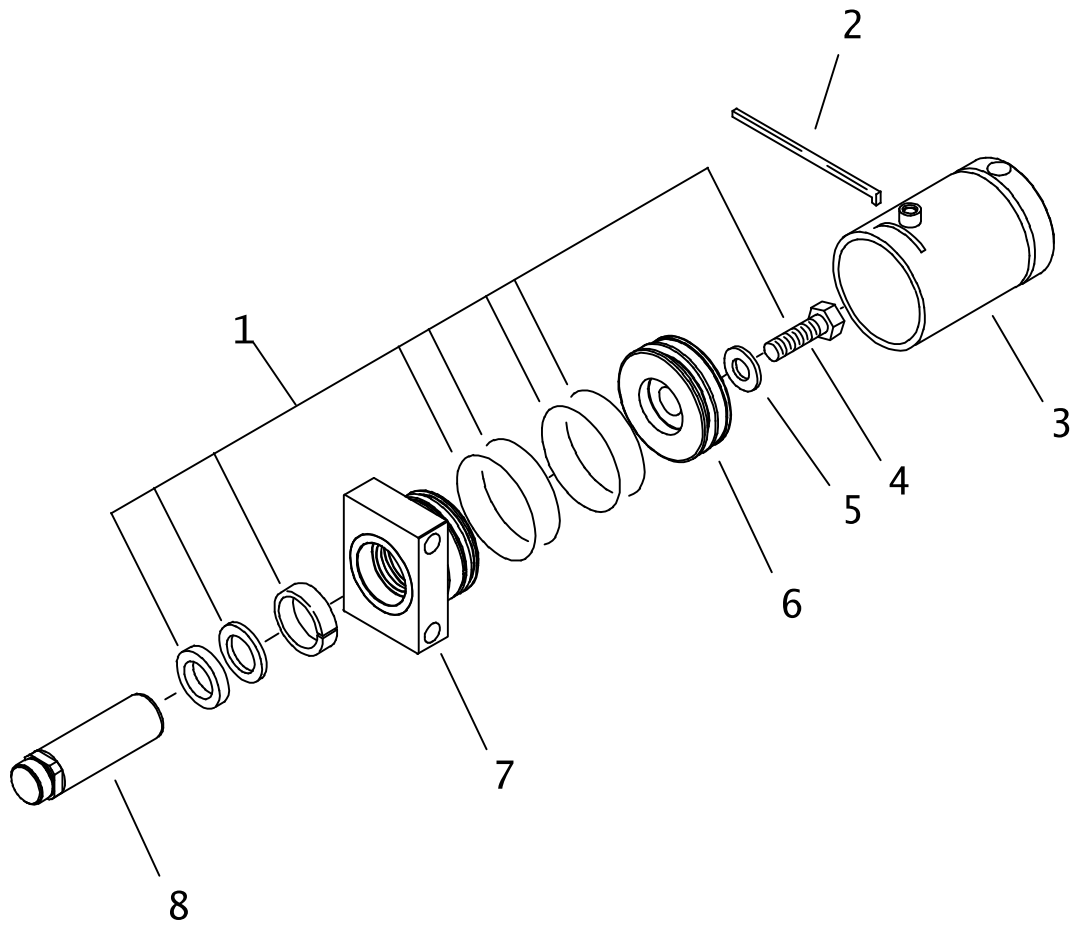

## HYDRAULIC CYLINDER CYLINDER (4.50" X 2.25' X 2.75")

REF NO.	PART NUMBER	QTY	DESCRIPTION	REMARKS
	156-2006		CYL 4.50" X 2.25" X 2.75"	INCLUDES REF NO.'S 2 THRU 8 <u>OBSOLETE</u>
1.	190-900	1	SEAL REPAIR KIT	
2.	150-711	1	LOCK RING	
3.	152-073	1	4.5 X 2.75 BARREL	
4.	106-146	1	BOLT (1-1/8-NC X 2-1/2" GD8)	SEE FOOTNOTE 1
5.	106-147	1	WASHER (1-1/8")	
6.	149-168	1	4.5 X 2.25 PISTON	SEE FOOTNOTE 2
7.	151-207	1	GLAND	
8.	150-710	1	CYLINDER ROD	<u>OBSOLETE</u>
	153-753	1	CYLINDER ROD	SEE FOOTNOTE 3

### NOT SHOWN:

259-040 U-SEAL INSTALLER (1.500"- UP

### FOOTNOTES:

1. USE LOCTITE 271 OR 277. TORQUE TO 770-850 FT-LBS (1045-1150 N.M.).
2. UNITIZED PISTON INCLUDES WEAR RING, SQUARE LOADER RING & PISTON SEAL.
3. USES 329-179 JAW BLOCK AND 107-777 SPRING PIN.

### NOTE:



# **ELECTRICAL**

# ELECTRICAL SCHEMATIC

JT2720AT MACH1

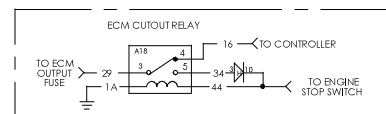
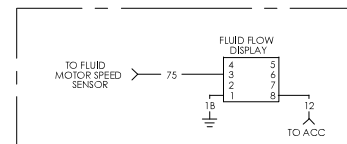
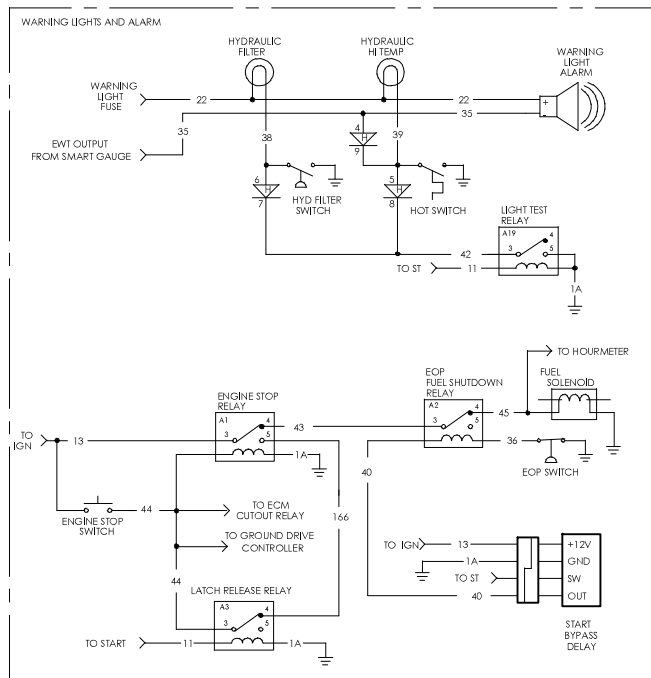
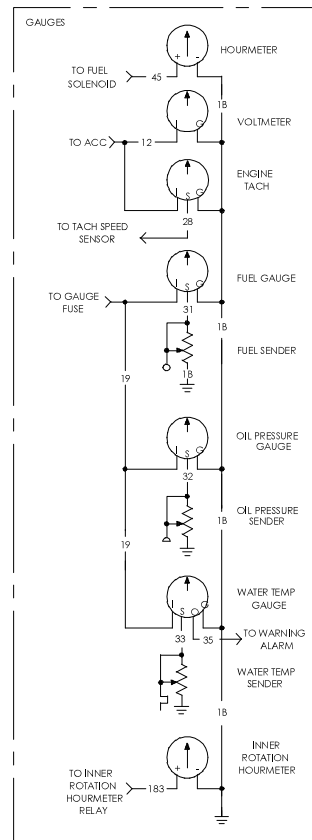
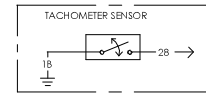
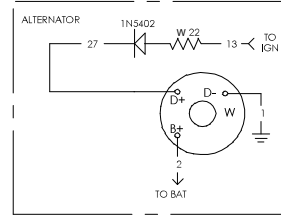
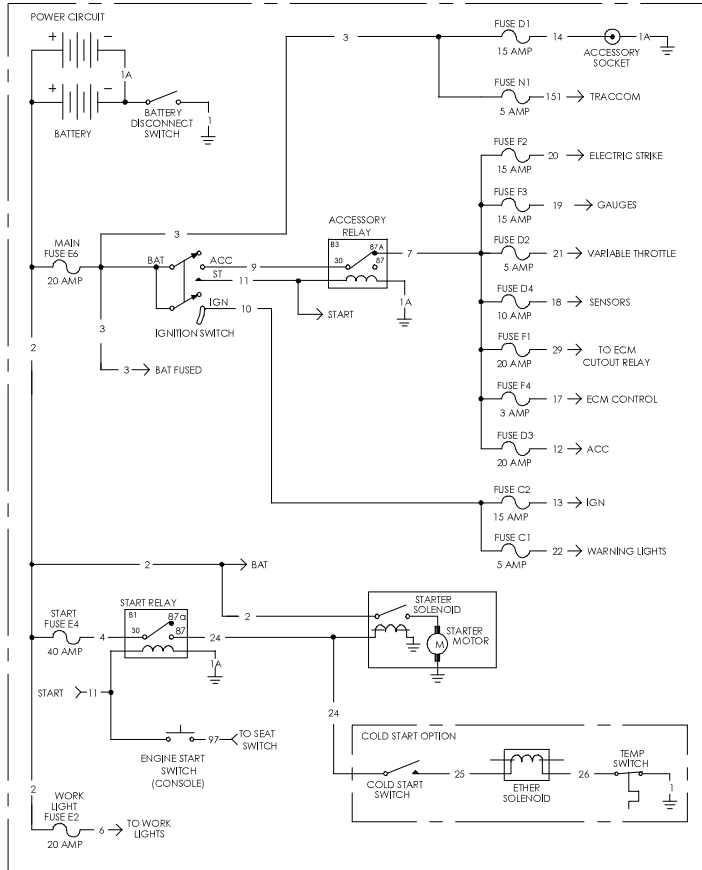

E

807-878



# ELECTRICAL SCHEMATIC

## JT2720AT MACH I

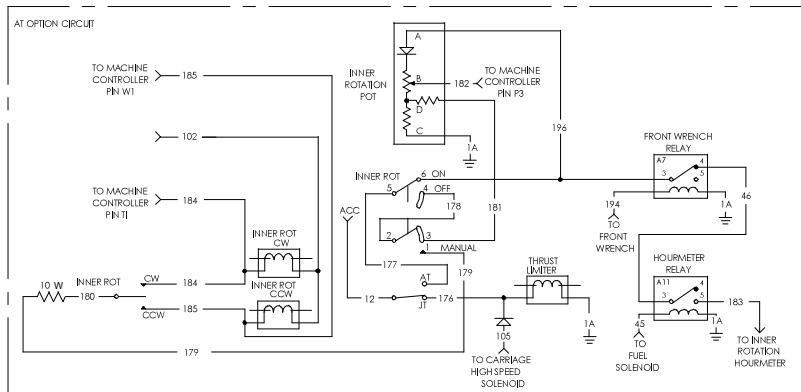
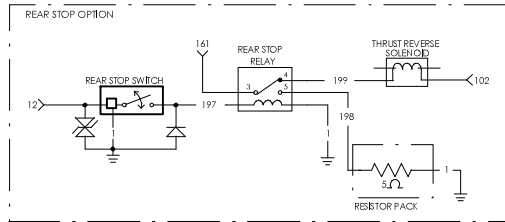
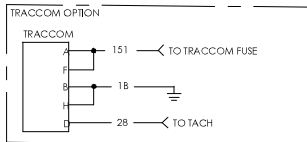
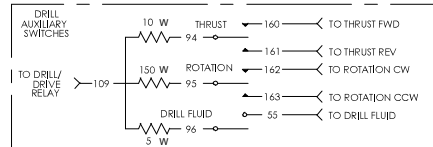
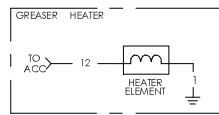
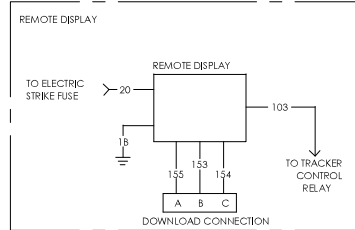
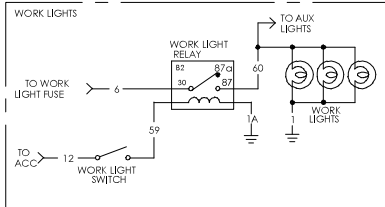
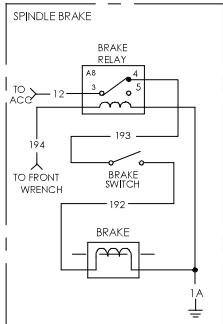
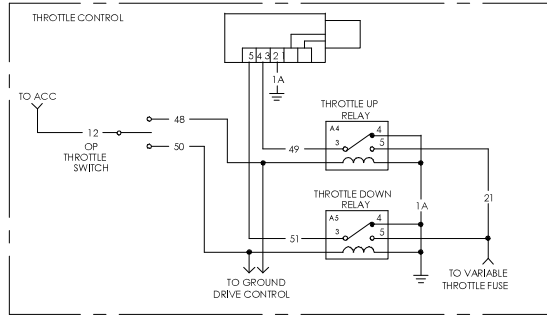
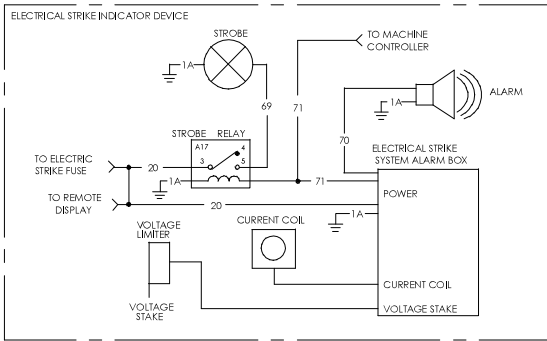

# ELECTRICAL SCHEMATIC

## JT2720AT MACH1

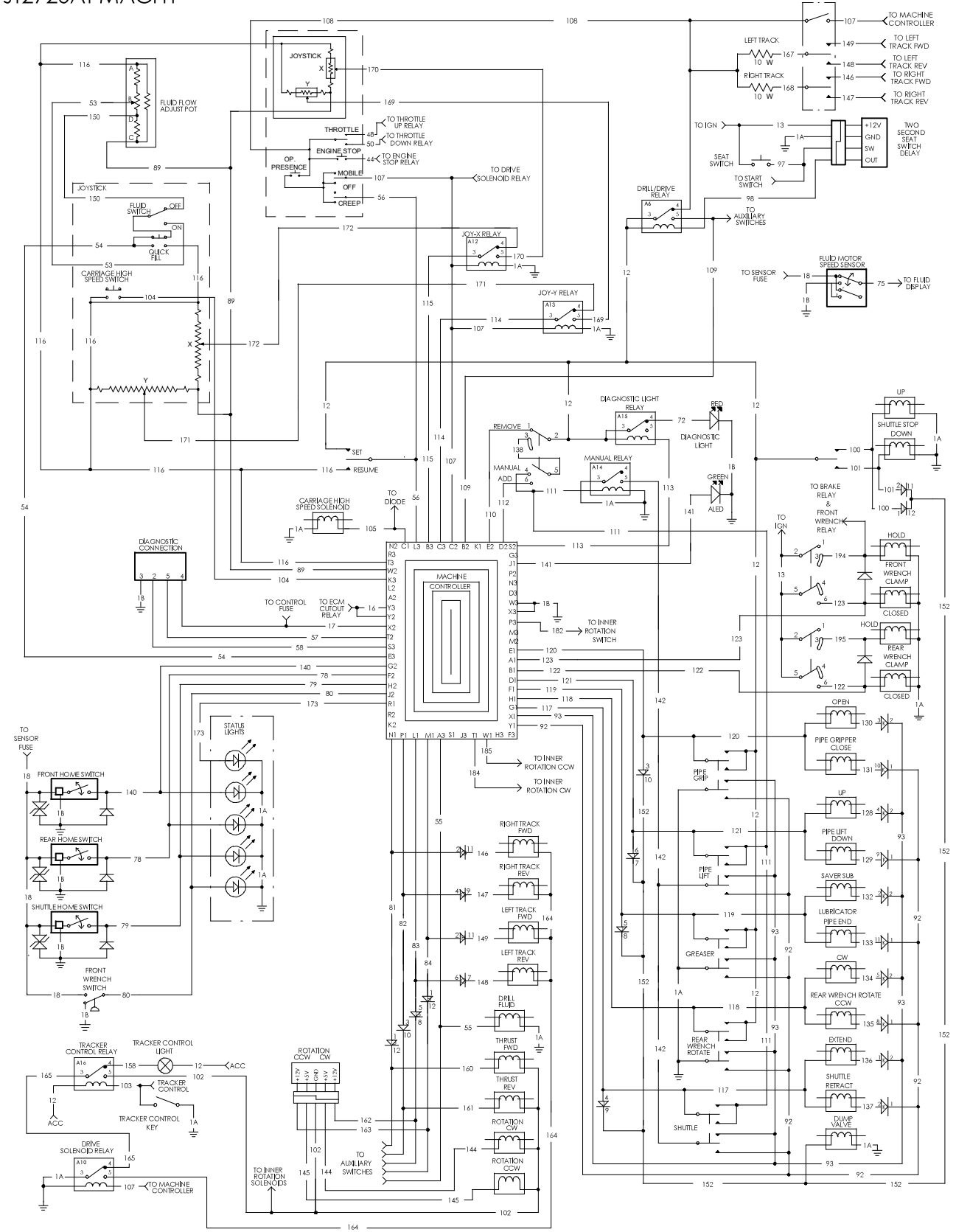

E

807-878

# ELECTRICAL SCHEMATIC

JT2720AT MACH1

CKT NO.	WIRE COLOR	FUNCTION	REMARKS
1.	BLK	SYSTEM GROUND & HIGH LOAD GROUND	
1A.	BLK/RED	MEDIUM LOAD GROUND	
1B.	BLK/BLU	LOW LOAD GROUND	
2.	RED	BATTERY POSITIVE TO FUSE BLOCK	
3.	RED	FUSED BATTERY POWER	
4.	RED/BLK	START FUSE TO START RELAY	
5.		NOT USED	
6.	BLU	WORK LIGHT FUSE TO RELAY	
7.	BRN	ACCESSORY RELAY CIRCUIT	
8.		NOT USED	
9.	ORG	IGNITION SWITCH ACCESSORY TO ACCESSORY RELAY	
10.	ORG/BLU	IGNITION SWITCH IGNITION CIRCUIT	
11.	WHT/BLK	IGNITION SWITCH START CIRCUIT	
12.	ORG	FUSED ACCESSORY CIRCUIT	
13.	ORG/GRN	FUSED IGNITION CIRCUIT	
14.	RED/WHT	ACCESSORY SOCKET CIRCUIT	
15.		NOT USED	
16.	RED/GRN	ECM CUTOFF RELAY TO MACHINE CONTROLLER	
17.	RED/BLU	MACHINE CONTROLLER CONTROL FUSE CIRCUIT	
18.	RED/BLK	SENSOR/SWITCH FUSE CIRCUIT	
19.	ORG/BRN	GAUGE CIRCUIT	
20.	RED/YEL	ELECTRIC STRIKE CIRCUIT	
21.	RED/ORG	VARIABLE THROTTLE CIRCUIT	
22.	GRA/ORG	WARNING LIGHT & ALARM CIRCUIT	
23.		NOT USED	
24.	PUR	START RELAY TO STARTER & COLD START OPTION	
25.	BRN/ORG	COLD START SWITCH TO ETHER SOLENOID	
26.	BLK	ETHER SOLENOID TO TEMP SWITCH	
27.	ORG/BLU	RESISTOR - DIODE TO ALTERNATOR EXCITER CONNECTION	
28.	YEL	ALTERNATOR TO TACHOMETER	
29.	RED/BRN	ECM OUTPUT FUSE TO ECM CUTOFF RELAY	
30.		NOT USED	
31.	BRN	FUEL SENDER TO FUEL GAUGE	
32.	BLU	OIL PRESSURE SENDER TO OIL PRESSURE GAUGE	
33.	GRN	WATER TEMP SENDER TO WATER TEMP GAUGE	
34.	GRN/RED	ECM CUTOFF RELAY TO DIODE	
35.	BLU/RED	WARNING LIGHT ALARM (NEG) TO DIODES	
36.	WHT/BLU	EOP FUEL SHUTDOWN RELAY TO EOP SWITCH	
37.	WHT/GRN	ENGINE WATER TEMP OUTPUT FROM SMART GAUGE TO WARNING ALARM	
38.	GRA/YEL	HYDRAULIC FILTER SWITCH TO LIGHT & DIODE	
39.	GRA/BLK	HYDRAULIC OIL TEMP SWITCH TO LIGHT & DIODES	
40.	GRN	START BYPASS DELAY TIMER TO EOP FUEL SHUTDOWN RELAY	
41.		NOT USED	
42.	BLK/ORG	LIGHT TEST RELAY TO DIODES	
43.	BLU	ENGINE STOP RELAY TO EOP FUEL SHUTDOWN RELAY	
44.	YEL/RED	ENGINE STOP SWITCH TO ENGINE STOP RELAY, LATCH RELEASE RELAY, ECM CUTOFF RELAY, & DIODE	
45.	ORG/BLK	EOP FUEL SHUTDOWN RELAY TO FUEL SOLENOID AND HOURMETER	
46.	BLK/ORG	FRONT WRENCH RELAY TO HOURMETER RELAY	
47.		NOT USED	
48.	PUR/ORG	THROTTLE SWITCH TO THROTTLE UP RELAY	
49.	WHT/ORG	THROTTLE UP RELAY TO LINEAR ACTUATOR	
50.	BLU/ORG	THROTTLE SWITCH TO THROTTLE DOWN RELAY	
51.	GRN/ORG	THROTTLE DOWN RELAY TO LINEAR ACTUATOR	
52.		NOT USED	
53.	BLK/YEL	FLUID FLOW ADJUST POT TO FLUID SWITCH "ON"	
54.	BLK/WHT	MACHINE CONTROLLER TO ON-OFF FLUID SWITCH & QUICK-FILL SWITCH	
55.	WHT/BLK	MACHINE CONTROLLER TO DRILL FLUID SOLENOID	

# ELECTRICAL SCHEMATIC

JT2720AT MACH 1

CKT NO.	WIRE COLOR	FUNCTION	REMARKS
56.	TAN/WHT	MACHINE CONTROLLER TO SET/RESUME SWITCH & TETHER CREEP	
57.	PNK/BLU	MACHINE CONTROLLER TO DIAGNOSTICS CONNECTION "5"	
58.	PNK/WHT	MACHINE CONTROLLER TO DIAGNOSTICS CONNECTION "2"	
59.	TAN/RED	WORK LIGHT SWITCH TO WORK LIGHT RELAY	
60.	YEL	WORK LIGHT RELAY TO WORK LIGHTS & AUX LIGHT CONNECTION	
61.		NOT USED	
62.		NOT USED	
63.		NOT USED	
64.		NOT USED	
65.		NOT USED	
66.		NOT USED	
67.		NOT USED	
68.		NOT USED	
69.	WHT/YEL	STROBE RELAY TO STROBE	
70.	BRN	ESID TO LOCAL ESID ALARM	
71.	WHT/PUR	ESID TO STROBE RELAY & MACHINE CONTROLLER	
72.	PNK/BLK	STATUS LIGHT RELAY TO STATUS LIGHT	
73.		NOT USED	
74.		NOT USED	
75.	WHT/BRN	FLUID MOTOR SPEED SENSOR TO FLUID FLOW DISPLAY	
76.		NOT USED	
77.		NOT USED	
78.	GRA/WHT	REAR HOME POSITION SWITCH TO MACHINE CONTROLLER & LED	
79.	WHT/RED	SHUTTLE SWITCH TO MACHINE CONTROLLER & LED	
80.	WHT	FRONT WRENCH SWITCH TO MACHINE CONTROLLER & LED	
81.	BLU/ORG	MACHINE CONTROLLER TO THRUST FORWARD/RIGHT TRACK FORWARD DIODES	
82.	BLU/YEL	MACHINE CONTROLLER TO THRUST REVERSE/RIGHT TRACK REVERSE DIODES	
83.	GRA/ORG	MACHINE CONTROLLER TO ROTATION CW/LEFT TRACK REVERSE DIODES	
84.	GRA/YEL	MACHINE CONTROLLER TO ROTATION CCW/LEFT TRACK FORWARD DIODES	
85.	PUR/GRN	MACHINE CONTROLLER TO INNER ROTATION CW SOLENOID & INNER ROTATION MANUAL SWITCH	
86.		NOT USED	
87.		NOT USED	
88.		NOT USED	
89.	YEL/BLK	MACHINE CONTROLLER TO GROUND FOR JOYSTICKS AND POTENTIOMETER	
90.		NOT USED	
91.		NOT USED	
92.	GRN/BLK	MACHINE CONTROLLER TO PIPELOADER FUNCTION SWITCHES AND DIODES	
93.	BLU/BLK	MACHINE CONTROLLER TO PIPELOADER FUNCTION SWITCHES AND DIODES	
94.	WHT/ORG	RESISTOR TO THRUST AUXILIARY SWITCH	
95.	WHT/RED	RESISTOR TO ROTATION AUXILIARY SWITCH	
96.	WHT/BLU	RESISTOR TO DRILL FLUID AUXILIARY SWITCH	
97.	BLU/YEL	SEAT SWITCH TO FIVE SECOND DELAY TIMER & START SWITCH	
98.	RED/WHT	BORE/MOBILE ENABLE RELAY TO SEAT SWITCH TIMER	
99.		NOT USED	
100.	PUR/WHT	SHUTTLE STOP SWITCH TO UP SOLENOID	
101.	BLU/WHT	SHUTTLE STOP SWITCH TO DOWN SOLENOID	
102.	WHT/GRN	REMOTE ENABLE RELAY TO ROTATION AND THRUST SOLENOIDS & ROTATION TRANSLATOR	
103.	TAN/RED	REMOTE ENABLE RELAY TO REMOTE DISPLAY & REMOTE ENABLE KEY	
104.	PUR/RED	CARRIAGE HIGH SPEED SWITCH TO MACHINE CONTROLLER	
105.	PUR/ORG	MACHINE CONTROLLER TO CARRIAGE HIGH SPEED SOLENOID	
106.		NOT USED	
107.	YEL/GRN	MOBILE SELECTOR SWITCH TO MACHINE CONTROLLER, JOY-X RELAY, JOY-Y RELAY & MOBILE SOLENOID RELAY	
108.	GRA	BORE/MOBILE RELAY TO TRACK DRIVE RESISTORS, TETHER CONTROL, & INNER ROTATION RELAY	
109.	YEL/PUR	BORE/MOBILE RELAY TO MACHINE CONTROLLER & BORE RESISTORS	
110.	BRN/ORG	REMOVE/MANUAL/ADD SWITCH TO MACHINE CONTROLLER	

# ELECTRICAL SCHEMATIC

JT2720AT MACH1

CKT NO.	WIRE COLOR	FUNCTION	REMARKS
111.	WHT/ORG	REMOVE/MANUAL/ADD SWITCH TO PIPELOADER FUNCTION SWITCHES & MANUAL RELAY	
112.	BRN/YEL	REMOVE/MANUAL/ADD SWITCH TO MACHINE CONTROLLER	
113.	TAN/BLK	MACHINE CONTROLLER TO STATUS LIGHT RELAY	
114.	GRA/GRN	JOYSTICK Y-AXIS RELAY TO MACHINE CONTROLLER	
115.	TAN/GRN	JOYSTICK X-AXIS RELAY TO MACHINE CONTROLLER	
116.	BLU/GRN	5 VOLT OUTPUT FROM MACHINE CONTROLLER	
117.	TAN	MACHINE CONTROLLER TO SHUTTLE SWITCH AND SOLENOIDS	
118.	PUR	MACHINE CONTROLLER TO REAR WRENCH ROTATE SWITCH AND SOLENOIDS	
119.	GRA	MACHINE CONTROLLER TO LUBRICATOR SWITCH AND SOLENOIDS	
120.	GRN	MACHINE CONTROLLER TO PIPE GRIP SWITCH AND SOLENOIDS	
121.	BLU	MACHINE CONTROLLER TO PIPE LIFT SWITCH AND SOLENOIDS	
122.	YEL	MACHINE CONTROLLER TO REAR WRENCH SWITCH, REAR WRENCH CLOSE SOLENOID, & DIODE	
123.	BRN	MACHINE CONTROLLER TO FRONT WRENCH SWITCH, FRONT WRENCH CLOSE SOLENOID, & DIODE	
124.		NOT USED	
125.		NOT USED	
126.		NOT USED	
127.		NOT USED	
128.	BLU/GRN	PIPE LIFT UP SOLENOID TO DIODE ANODE	
129.	BLU/YEL	PIPE LIFT DOWN SOLENOID TO DIODE ANODE	
130.	GRN/BLU	PIPE GRIPPER OPEN SOLENOID TO DIODE ANODE	
131.	GRN/ORG	PIPE GRIPPER CLOSE SOLENOID TO DIODE ANODE	
132.	GRA/GRN	SAVER SUB LUBRICATOR SOLENOID TO DIODE ANODE	
133.	GRA/YEL	PIPE END LUBRICATOR SOLENOID TO DIODE ANODE	
134.	PUR/GRN	REAR WRENCH ROTATE CW SOLENOID TO DIODE ANODE	
135.	PUR/YEL	REAR WRENCH ROTATE CCW SOLENOID TO DIODE ANODE	
136.	TAN/GRN	SHUTTLE EXTEND SOLENOID TO DIODE ANODE	
137.	TAN/WHT	SHUTTLE RETRACT SOLENOID TO DIODE ANODE	
138.	WHT	JUMPER ON REMOVE/MANUAL/ADD SWITCH	
139.		NOT USED	
140.	TAN/RED	FRONT HOME SWITCH TO MACHINE CONTROLLER & LED	
141.	PNK	MACHINE CONTROLLER TO ALED	
142.	WHT/RED	MANUAL RELAY TO MANUAL PIPELOADER SWITCHES	
143.		NOT USED	
144.	PUR/ORG	ROTATION CW VOLTAGE TRANSLATOR TO SOLENOID	
145.	PUR/YEL	ROTATION CCW VOLTAGE TRANSLATOR TO SOLENOID	
146.	GRN/PUR	RIGHT TRACK FORWARD DIODE TO RIGHT TRACK FORWARD SOLENOID	
147.	GRN/RED	RIGHT TRACK REVERSE DIODE TO RIGHT TRACK REVERSE SOLENOID	
148.	GRN/YEL	LEFT TRACK REVERSE DIODE TO LEFT TRACK REVERSE SOLENOID	
149.	GRN/ORG	LEFT TRACK FORWARD DIODE TO LEFT TRACK FORWARD SOLENOID	
150.	YEL	FLUID FLOW POT 0.5V TO FLUID SWITCH "OFF"	
151.	BLU/RED	TRACCOM FUSE CIRCUIT	
152.	GRA/RED	DUMP VALUE SOLENOID TO DIODE ANODE	
153.	WHT	REMOTE DISPLAY TO DOWNLOAD CONNECTION "B"	
154.	YEL	REMOTE DISPLAY TO DOWNLOAD CONNECTION "C"	
155.	BLK	REMOTE DISPLAY TO DOWNLOAD CONNECTION "A"	
156.		NOT USED	
157.		NOT USED	
158.	GRA/PUR	REMOTE ENABLE RELAY TO REMOTE ENABLE LIGHT	
159.		NOT USED	
160.	TAN/ORG	THRUST FORWARD DIODE TO THRUST FORWARD SOLENOID	
161.	TAN/YEL	THRUST REVERSE DIODE TO REAR STOP RELAY	
162.	ORG/GRA	ROTATION CW DIODE TO ROTATION CW SOLENOID	
163.	YEL/GRA	ROTATION CCW DIODE TO ROTATION CCW SOLENOID	
164.	WHT/YEL	MOBILE SOLENOID RELAY TO TRACK DRIVE SOLENOIDS	
165.	TAN/PUR	REMOTE ENABLE SELECT RELAY TO MOBILE SOLENOID RELAY	
166.	WHT	ENGINE STOP RELAY TO LATCH RELEASE RELAY	
167.	BLU/WHT	RESISTOR TO LEFT TRACK AUXILIARY SWITCH	

## ELECTRICAL SCHEMATIC

JT2720AT MACH1

CKT NO.	WIRE COLOR	FUNCTION	REMARKS
168.	GRN/WHT	RESISTOR TO RIGHT TRACK AUXILIARY SWITCH	
169.	GRA/RED	TETHER JOYSTICK Y-AXIS OUTPUT TO JOY-Y RELAY	
170.	TAN/RED	TETHER JOYSTICK X-AXIS OUTPUT TO JOY-X RELAY	
171.	GRA/BLU	CONSOLE JOYSTICK Y-AXIS OUTPUT TO JOY-Y RELAY	
172.	TAN/BLU	CONSOLE JOYSTICK X-AXIS OUTPUT TO JOY-X RELAY	
173.	BRN/WHT	MACHINE CONTROLLER TO MUD PUMP "ON" LED	
174.		NOT USED	
175.		NOT USED	
176.	YEL/RED	JT SWITCH TO THRUST LIMITER SOLENOID	
177.	YEL/BLU	AT SWITCH TO INNER ROTATION ON/OFF/MANUAL SWITCH	
178.	PUR	INNER ROTATION SWITCH JUMPER	
179.	TAN/YEL	INNER ROTATION MANUAL SWITCH TO RESISTOR	
180.	TAN/ORG	RESISTOR TO INNER ROTATION MANUAL SWITCH	
181.	BLU/PUR	INNER ROTATION MANUAL SWITCH TO INNER ROTATION OFF RELAY	
182.	TAN/BLU	INNER ROTATION POT TO MACHINE CONTROLLER	
183.	YEL/WHT	HOURLMETER RELAY TO INNER HOURLMETER	
184.	BRN/BLU	MACHINE CONTROLLER TO INNER ROTATION CW SOLENOID & INNER ROTATION MANUAL SWITCH	
185.	BRN/RED	MACHINE CONTROLLER TO INNER ROTATION CCW SOLENOID & INNER ROTATION MANUAL SWITCH	
186.		NOT USED	
187.		NOT USED	
188.		NOT USED	
189.		NOT USED	
190.		NOT USED	
191.		NOT USED	
192.	PUR/WHT	SPINDLE BRAKE SWITCH TO SPINDLE BRAKE SOLENOID	
193.	PUR/RED	BRAKE RELAY TO BRAKE SWITCH	
194.	BRN/WHT	FRONT WRENCH SWITCH TO FRONT WRENCH OPEN SOLENOID, BRAKE RELAY, & FRONT WRENCH RELAY	
195.	YEL/WHT	REAR WRENCH SWITCH TO REAR WRENCH OPEN SOLENOID, & DIODE	
196.	BRN/BLK	INNER ROTATION ON SWITCH TO FRONT WRENCH RELAY, & INNER ROTATION POT	
197.	WHT	REAR STOP SWITCH TO REAR STOP RELAY	
198.	YEL/TAN	REAR STOP RELAY TO RESISTOR PACK	
199.	TAN/BLK	REAR STOP RELAY TO REVERSE THRUST SOLENOID	



# ELECTRICAL DIAGRAM

## VOLTAGE TRANSLATER HARNESS

BEGINS WITH S/N: 2V2293

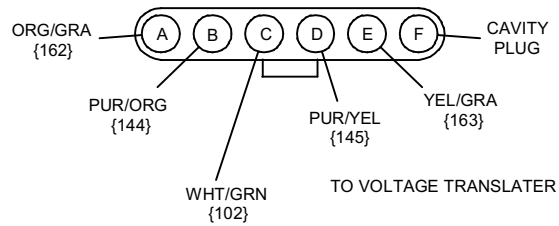
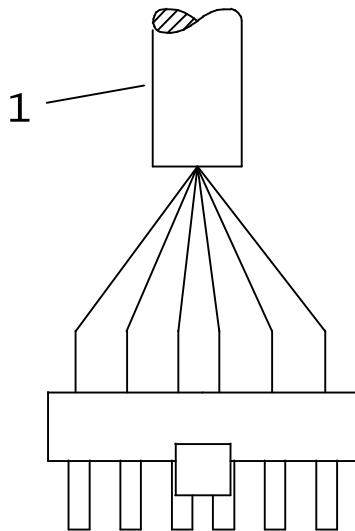
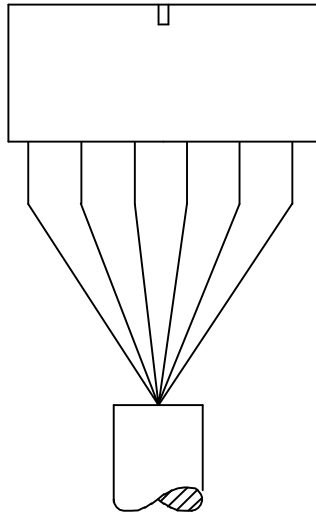
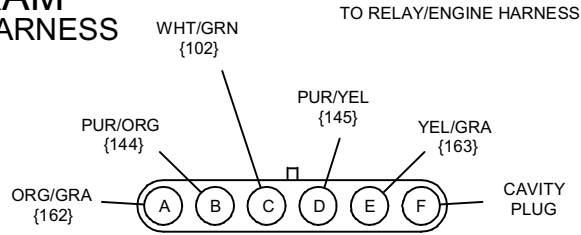



**ELECTRICAL DIAGRAM**  
**VOLTAGE TRANSLATER HARNESS**  
**BEGINS WITH S/N: 2V2293**

REF	PART				
NO.	NUMBER	QTY	DESCRIPTION		REMARKS
1.	214-893	1	VOLTAGE TRANSLATOR JUMPER		

NOT SHOWN:

FOOTNOTES:

NOTE:

# ELECTRICAL DIAGRAM

## FAN CLUTCH

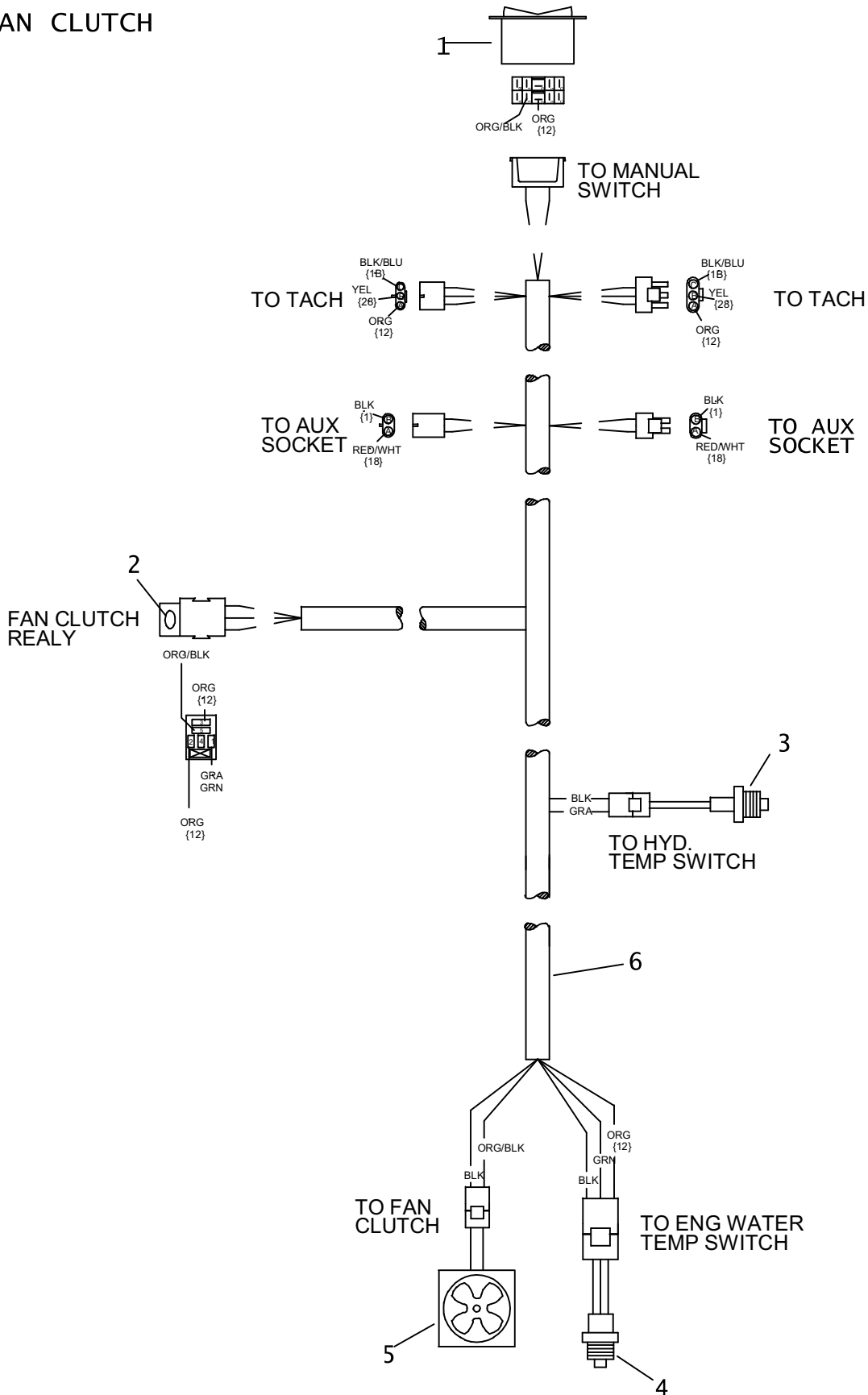

## ELECTRICAL DIAGRAM

### FAN CLUTCH

REF NO.	PART NUMBER	QTY	DESCRIPTION	REMARKS
1.	217-907	1	ROCKER SWITCH (DPDT) ON-ON	
2.	217-710	1	MICRO RELAY (SPDT)	
3.	214-842	1	TEMPERATURE SWITCH	
4.	214-895	1	TEMPERATURE SWITCH	
5.	194-251	1	FAN DRIVE (JT/AT 2720)	
6.	214-896	1	FAN CLUTCH HARNESS	

FOOTNOTES

NOTE:

B

808-297

# ELECTRICAL DIAGRAM

## VARIABLE SPEED INNER ROTATION HARNESS

BEGINS WITH S/N 2V1098

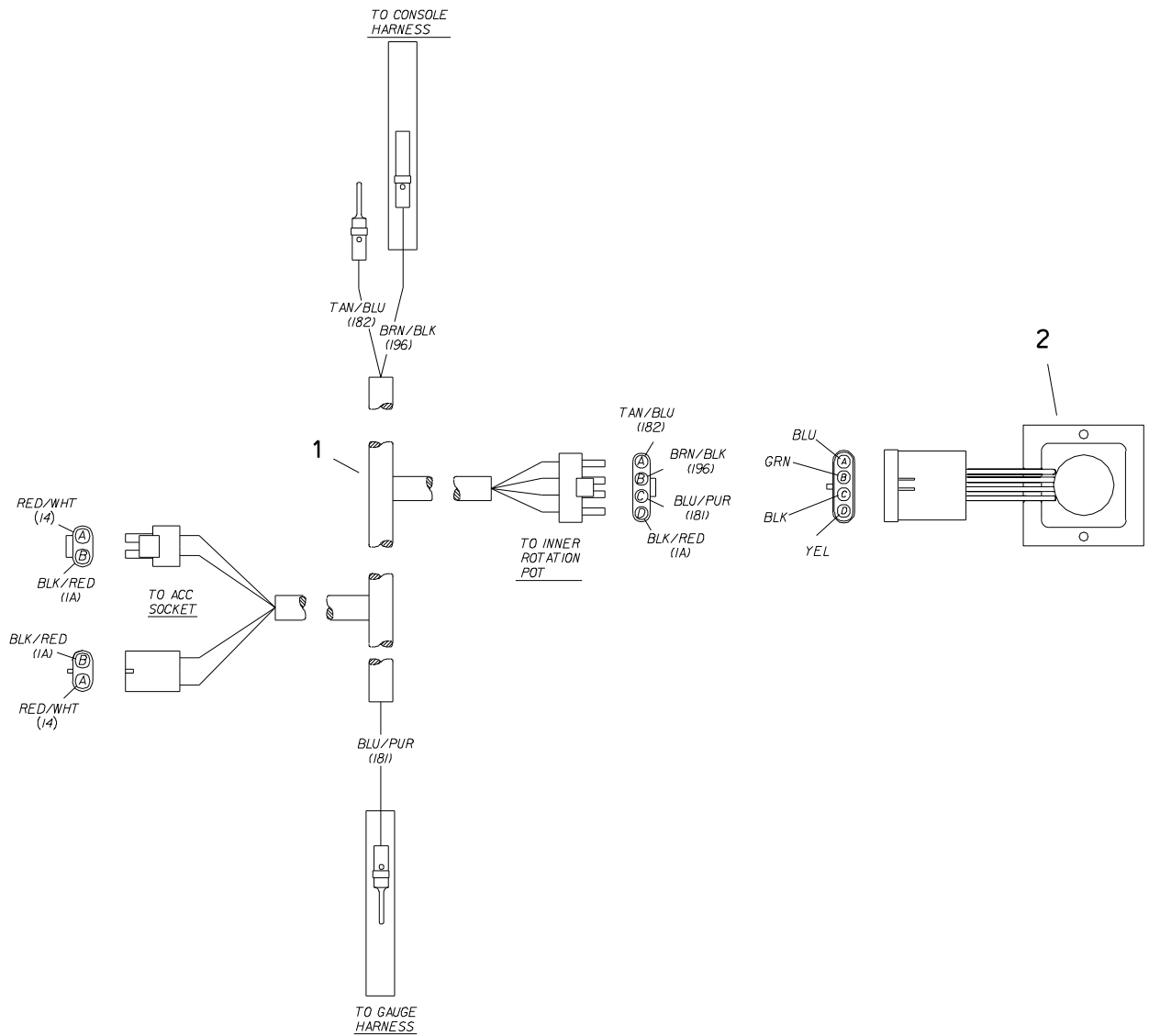

# ELECTRICAL DIAGRAM

## VARIABLE SPEED INNER ROTATION HARNESS

### BEGINS WITH S/N 2V1098

REF NO.	PART NUMBER	QTY	DESCRIPTION	REMARKS
1.	214-849	1	VARIABLE INNER ROTATION HARNES	
2.	211-089	1	4.5V-12.0V POTENTIOMETER	

FOOTNOTES

# ELECTRICAL DIAGRAM

## RELAY/ENGINE HARNESS

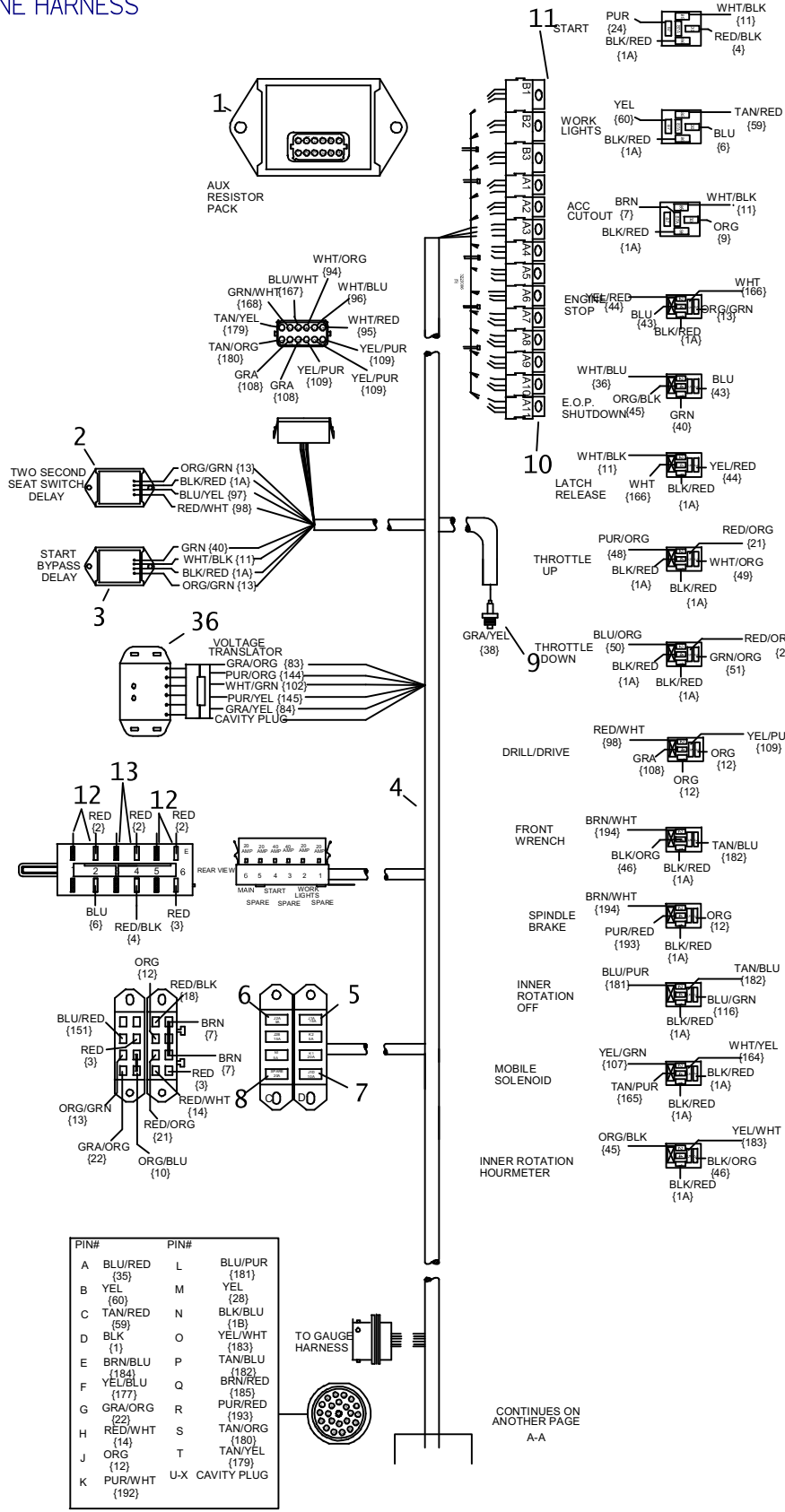

PIN#	PIN#	PIN#	
A	BLU/RED (35)	L	BLU/PUR (181)
B	YEL (60)	M	YEL (28)
C	TAN/RED (59)	N	BLK/BLU (18)
D	BLK (1)	O	YEL/WHT (183)
E	BRN/BLU (184)	P	TAN/BLU (182)
F	YEL/BLU (177)	Q	BRN/RED (185)
G	GRA/ORG (22)	R	PUR/RED (193)
H	RED/WHT (14)	S	TAN/ORG (180)
J	ORG (12)	T	TAN/YEL (179)
K	PUR/WHT (192)	U-X	CAVITY PLUG

CONTINUES ON ANOTHER PAGE  
A-A

# ELECTRICAL DIAGRAM

## RELAY/ENGINE HARNESS

PIN#	PIN#	PIN#
1 YEL/GRN (107)	11 TAN/RED (140)	21 GRN/BLK (92)
2 WHT/RED (95)	12 PUR/WHT (100)	22 BLU/BLK (93)
3 TAN/WHT (56)	13 BLU/WHT (101)	23 BLU (32)
4 GRA/RED (169)	14 BRN/RED (185)	24 GRN (33)
5 TAN/RED (170)	15	25 WHT/BLU (96)
6 PUR/ORG (105)	16 PUR (118)	26 GRA/ORG (22)
7 GRA/PUR (158)	17 GRA (109)	27 YEL/PUR (109)
8 GRA/WHT (78)	18 BLU (121)	28 GRN/PUR (146)
9 WHT/RED (79)	19 YEL (122)	29 GRN/RED (147)
10 WHT (80)	20 BRN (123)	30 GRN/YEL (148)
		31 GRN/ORG (149)

PIN#	PIN#	PIN#
1 YEL/RED (44)	11 BLU/RED (35)	21 BLK/RED (1A)
2 BLU/GRN (116)	12 WHT/ORG (94)	22 WHT/BLK (11)
3 WHT/GRN (102)	13 WHT/BRN (75)	23 GRA/YEL (38)
4 WHT/YEL (89)	14 WHT/BLK (155)	24 ORG/GRN (13)
5 BLU/ORG (50)	15 GRA/YEL (84)	25 BLU/YEL (97)
6 ORG (12)	16 BLK/BLU (18)	26 GRN (120)
7 YEL/BLK (89)	17 GRA/ORG (27)	27 YEL/WHT (194)
8 GRA/BLK (39)	18 BLU/YEL (82)	28 BRN/WHT (194)
9 TAN/BLU (182)	19 PUR/ORG (48)	29 BRN (31)
10 BRN (7)	20 BLU/ORG (61)	30 BRN/BLU (164)
		31 TAN/PUR (165)

PIN#	PIN#	PIN#
1 BLU (121)	11 GRA/WHT (76)	21 BLK/RED (1A)
2 GRN/BLK (92)	12 PUR (118)	22 ORG (12)
3 TAN (117)	13 GRN (120)	23 BLK/BLU (18)
4 YEL/WHT (195)	14 RED/BLK (18)	24 PUR/WHT (192)
5 WHT (80)	15 BRN (123)	25 CAVITY PLUG (151)
6 TAN/RED (140)	16 BRN/WHT (194)	26 CAVITY PLUG (28)
7 BLU/BLK (93)	17 PUR/WHT (100)	27 CAVITY PLUG (18)
8 WHT/RED (79)	18 BLU/WHT (101)	28 CAVITY PLUG (18)
9 GRA (119)	19 YEL (122)	29 CAVITY PLUG (18)
10 BLK (1)	20 GRA/PUR (158)	30 CAVITY PLUG (18)
		31 CAVITY PLUG (18)

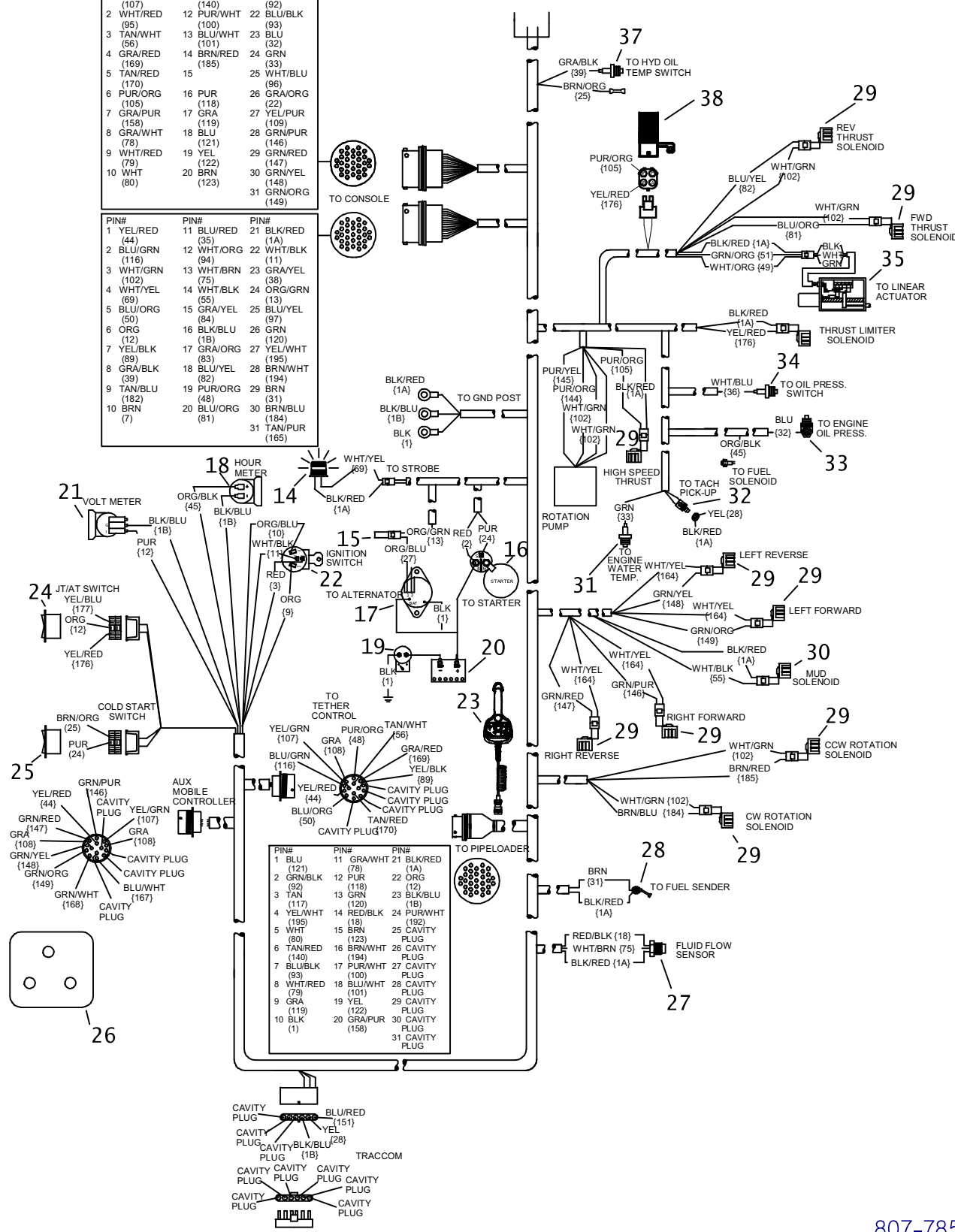

E

807-785

## ELECTRICAL DIAGRAM

### RELAY/ENGINE HARNESS

REF NO.	PART NUMBER	QTY	DESCRIPTION	REMARKS
1.	211-031	1	BORE/MOBILE RESISTOR PACK	
2.	217-184	1	DELAY TIMER (2-SECOND)	
3.	217-937	1	START BYPASS DELAY TIMER	
4.	214-746	1	RELAY/ENGINE HARNESS	
5.	217-811	2	FUSE (ATC, 15 AMP)	
6.	217-809	3	FUSE (ATC, 5 AMP)	
7.	217-810	1	FUSE (ATC, 10 AMP)	
8.	217-812	2	FUSE (ATC, 20 AMP)	
9.	N/A	1	RESTRICTION SWITCH	
10.	217-710	11	MICRO RELAY (SPDT)	
11.	217-826	3	MINI RELAY (SPDT)	
12.	217-805	4	FUSE (MAXI, 20AMP)	
13.	217-791	2	FUSE (MAXI, 40 AMP)	
14.	214-722	1	STROBE LIGHT (AMBER)	OBSOLETE
	214-296	1	STROBE LIGHT AMBER MED PROFILE	
15.	214-256	1	DIODE CONNECTOR	
16.	195-897	1	STARTER	
17.	217-450	1	ALTERNATOR (JT2720)	
18.	215-128	1	HOUR METER	
19.	217-819	1	BAT DISCONNECT SWITCH	
20.	215-244	2	BATTERY	
21.	215-129	1	VOLT METER	
22.	214-852	1	IGNITION SWITCH	BEGINS WITH S/N
	214-961		KEY, PAIR (BASE CODE)	
	214-962		SWITCH MOUNTING NUT	
	214-963		LOCK PLUG W/1 KEY (BASE CODE)	
	217-768	1	IGNITION SWITCH	OBSOLETE ENDS WITH S/N
23.	214-589	1	GROUND DRIVE CONTROL	
	197-102		REBUILT 214-589 CONTROL	
24.	217-907	1	ROCKER SWITCH (DPDT) ON-ON	
25.	217-917	1	ROCKER SWTCH (DPDT) OFF-(ON)	
26.	214-648	1	OVERRIDE CONTROL BOX	
27.	214-010	1	SPEED SENSOR	
28.	353-420	1	FUEL SENDER	
29.	214-434	8	SOLENOID COIL (SMALL)	
30.	217-897	1	SOLENOID COIL (LARGE)	
31.	217-550	1	WATER TEMPERATURE SENDER	
32.	N/A	1	TACHOMETER PICKUP	
33.	215-113	1	OIL PRESSURE SENDER	OBSOLETE
	215-183	1	SENDER, OIL PRESSURE HD	
34.	217-736	1	OIL PRESSURE SWITCH	
35.	215-231	1	LINEAR ACTUATOR	
36.	211-017	1	12V-5V VOLTAGE CONVERTOR	
37.	215-148	1	TEMPERATURE SWITCH	OBSOLETE
	214-819	1	TEMPERATURE SWITCH	
38.	214-449	1	DIODE PACK	

#### FOOTNOTES

NOTE:

E

807-785





# CONSOLE HARNESS

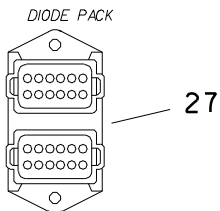
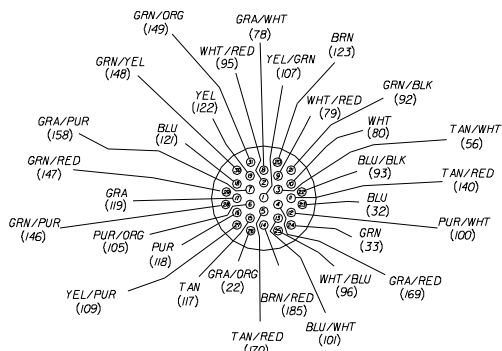
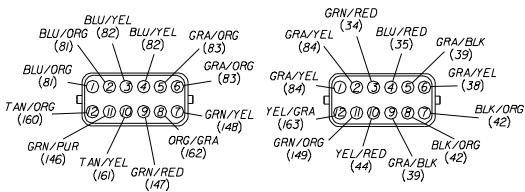
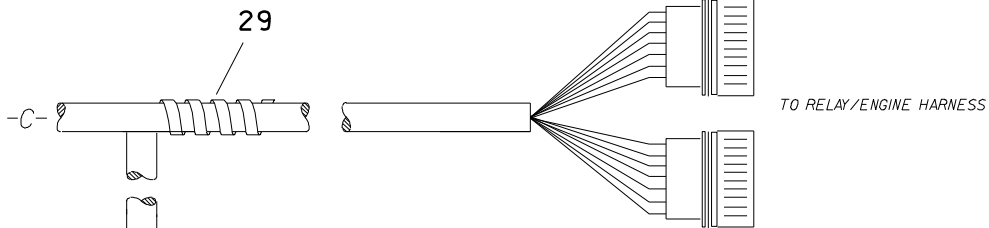
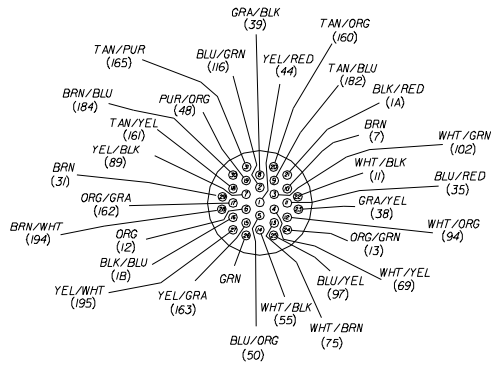

# CONSOLE HARNESS

REF NO.	PART NUMBER	QTY	DESCRIPTION	REMARKS
1.	214-741	1	CONSOLE HARNESS	
2.	217-710	8	MICRO RELAY (SPDT)	
3.	217-812	1	FUSE (ATC, 20 AMP)	
4.	217-811	2	FUSE (ATC, 15 AMP)	
5.	214-415	1	90D MODULE TO RIG CABLE	
6.	214-701	5	STATUS LIGHT	
7.	217-221	1	FLOW METER DISPLAY	
8.	214-563	1	RED LED 12V	
9.	214-840	1	GREEN LED (12V DC)	
10.	258-037	1	WATER TEMPERATURE GAUGE	
11.	217-020	1	PILOT LIGHT	
	217-027	1	INSERT (RED) HYD OIL HI TEMP	
	217-036	1	INSERT (YEL) HYD OIL PSI	
	217-074	2	LENS REFLECTOR	
12.	217-206	1	BUTTON SWITCH (SPST)	
13.	306-607	1	HORN BUTTON	
	306-608	1	BUTTON COVER	
14.	214-908	1	OFF-ON KEY SWITCH	
15.	216-059	1	CONTROL MODULE	
16.	215-131	1	OIL PRESSURE GAUGE	
17.	215-133	1	FUEL GAUGE	
18.	217-912	1	ROCKER SWITCH (DPDT) ON-ON-ON	
19.	214-489	6	ROCKER SW (DPDT) (ON)-OFF-(ON)	
20.	217-916	1	ROCKER SWITCH (DPDT) ON-OFF-ON	
21.	214-565	1	DUAL AXIS HALL EFFECT JOYSTICK	
	197-104		REBUILT 214-565 JOYSTICK	
22.	306-602	1	BACKUP ALARM	
23.	217-935	1	SEAT SWITCH	
24.	217-241	1	ESID MODULE	
25.	214-566	1	POTENTIOMETER	
26.	217-911	1	ROCKER SWITCH (SPDT) ON-OFF-ON	
27.	211-026	1	DIODE PACK (DEUTSCH)	
28.	214-811	1	TEMPERATURE GAUGE HARNESS	
29.	110-930	1	SPIRAL WRAP (1.5",SOLD PER FT)	1 @ 44", SEE FOOTNOTE 1

## FOOTNOTES

1. INSTALL SPIRAL WRAP " FROM THE #27 DIODE PACK BREAKOUT EXTENDING TOWARD THE RELAY ENGINE HARNESS CONNECTORS.

# CONSOLE HARNESS

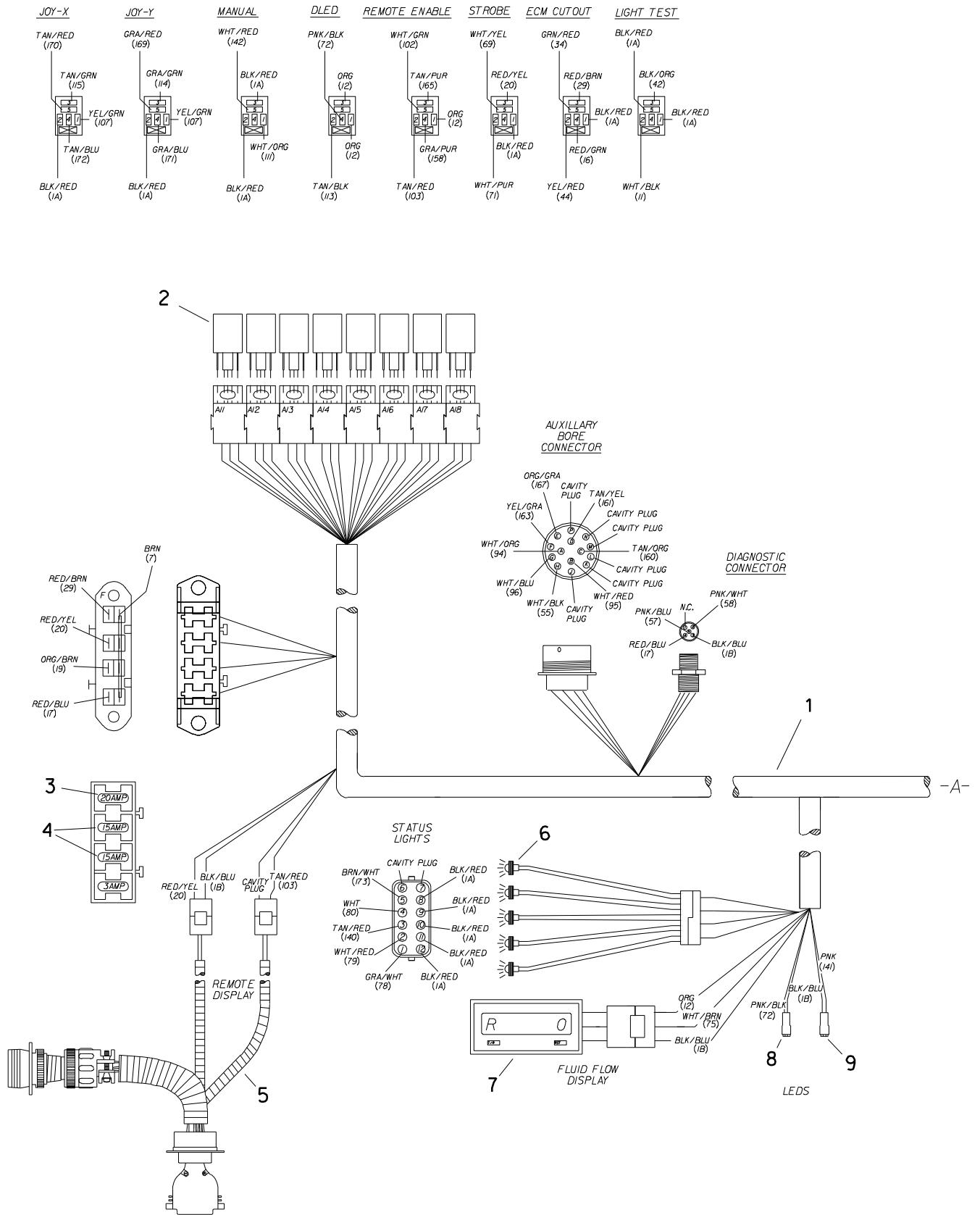

# CONSOLE HARNESS

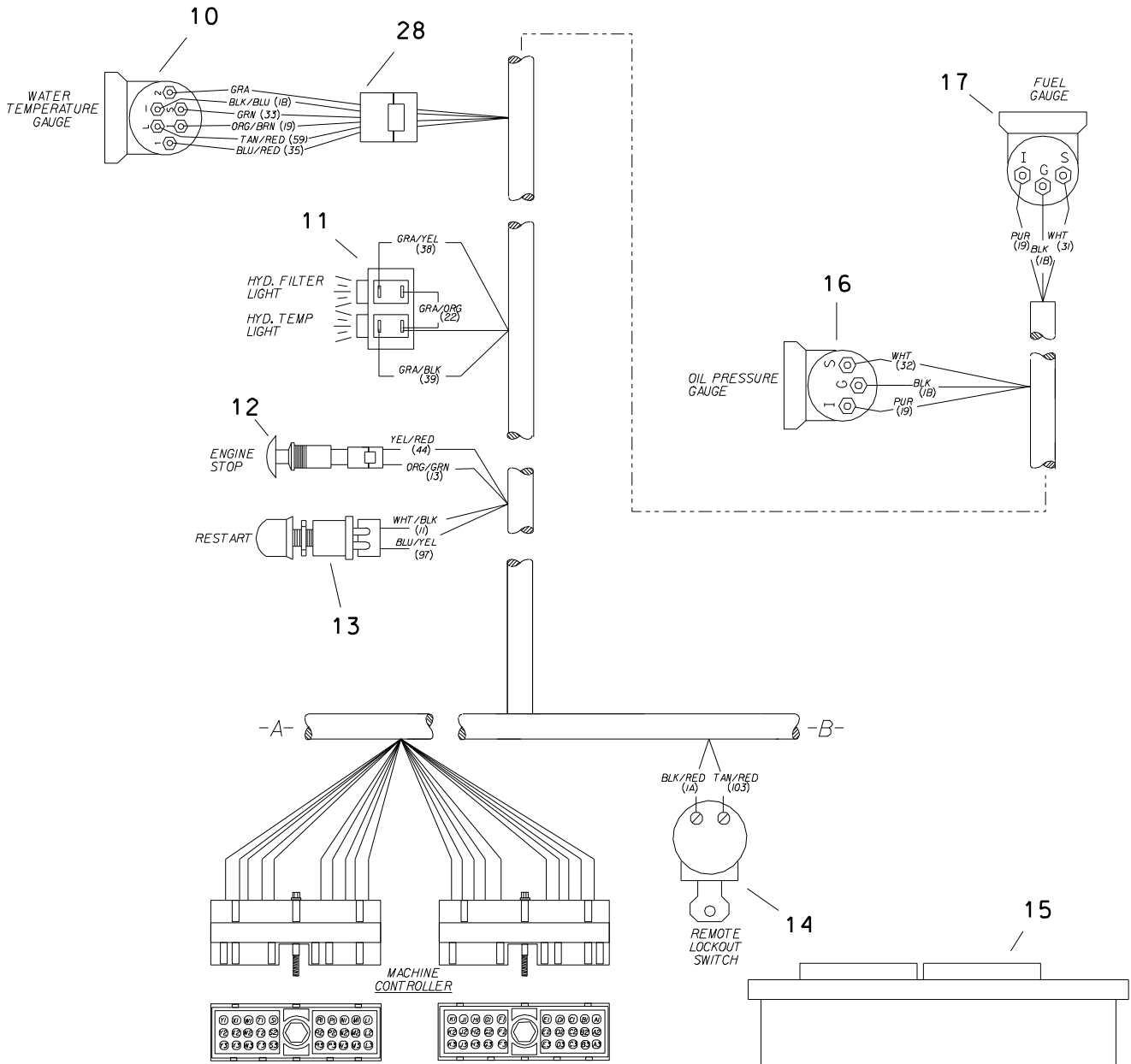

L1	GRA/ORG (83)	S1	NO CONNECTION	A1	BRN (123)	F1	GRA (119)
L2	NO CONNECTION	S2	TAN/BLK (113)	A2	NO CONNECTION	F2	GRA/WHT (78)
L3	TAN/WHT (56)	S3	PNK/WHT (58)	A3	WHT/BLK (55)	F3	NO CONNECTION
M1	GRA/YEL (84)	T1	BRN/BLU (184)	B1	YEL (122)	G1	TAN (117)
M2	NO CONNECTION	T2	PNK/BLU (57)	B2	YEL/PUR (109)	G2	TAN/RED (140)
M3	NO CONNECTION	T3	BLU/GRN (116)	B3	TAN/GRN (115)	G3	NO CONNECTION
N1	BLU/ORG (81)	W1	BRN/RED (185)	C1	PUR/ORG (105)	H1	PUR (118)
N2	NO CONNECTION	W2	YEL/BLK (89)	C2	YEL/GRN (107)	H2	WHT/RED (79)
N3	WHT/PUR (71)	W3	BLK/BLU (18)	C3	GRA/GRN (114)	H3	NO CONNECTION
P1	BLU/YEL (82)	X1	BLU/BLK (83)	D1	BLU (121)	J1	PNK (141)
P2	NO CONNECTION	X2	RED/BLU (17)	D2	BRN/YEL (112)	J2	WHT (80)
P3	TAN/BLU (182)	X3	BLK/BLU (18)	D3	NO CONNECTION	J3	NO CONNECTION
R1	BRN/WHT (73)	Y1	GRN/BLK (92)	E1	GRN (120)	K1	NO CONNECTION
R2	NO CONNECTION	Y2	RED/GRN (16)	E2	BRN/ORG (110)	K2	NO CONNECTION
R3	NO CONNECTION	Y3	RED/GRN (16)	E3	BLK/WHT (54)	K3	PUR/RED (104)

F

# CONSOLE HARNESS

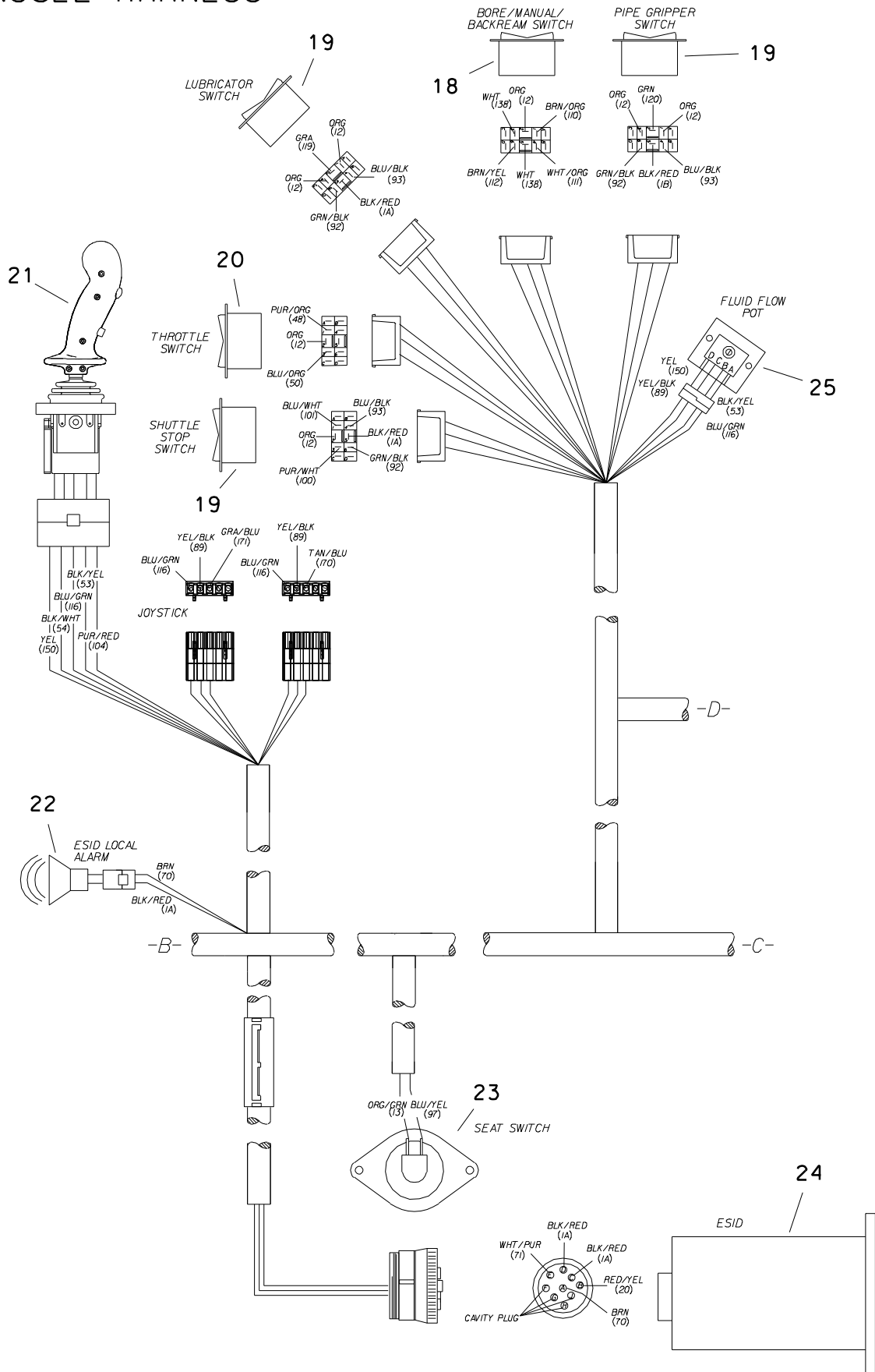

# CONSOLE HARNESS

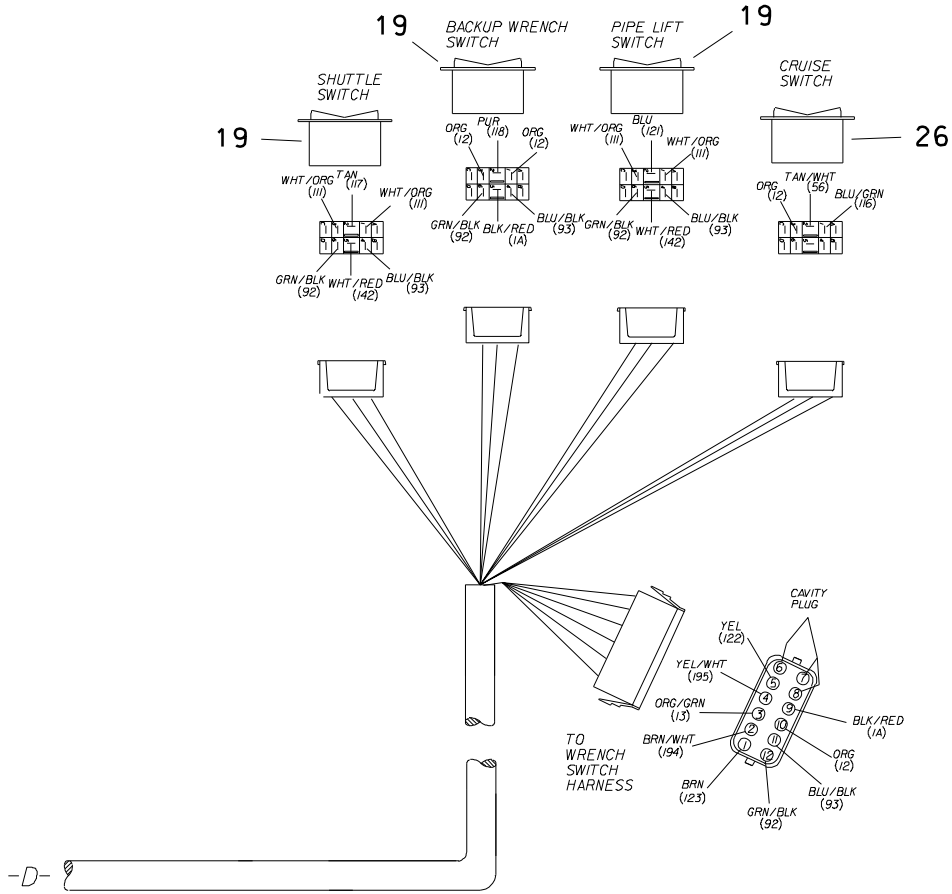

# ELECTRICAL DIAGRAM ALL TERRAIN GAUGE HARNESS

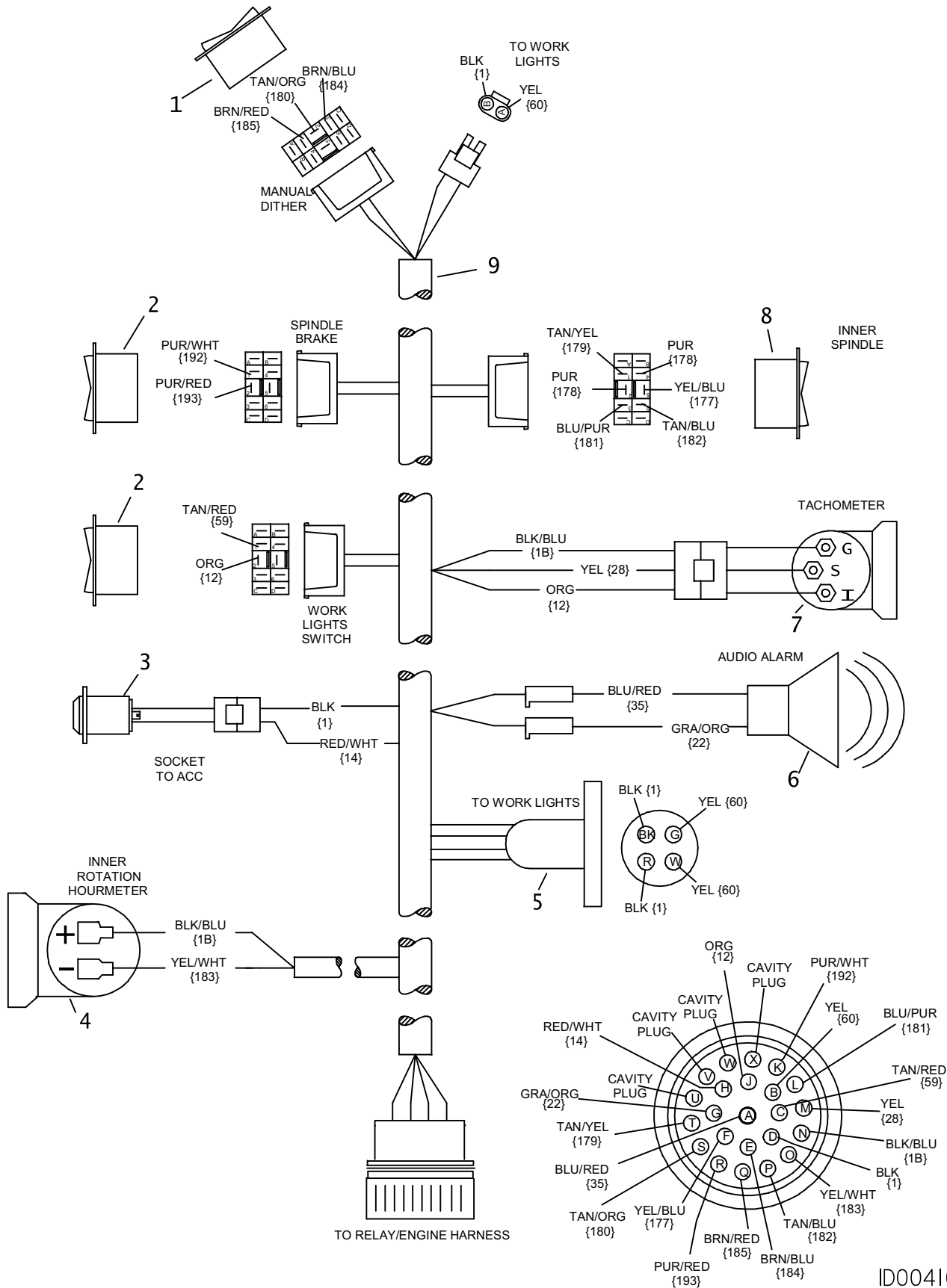



## ELECTRICAL DIAGRAM

### ALL TERRAIN GAUGE HARNESS

REF NO.	PART NUMBER	QTY	DESCRIPTION	REMARKS
1.	217-912	1	ROCKER SWITCH (DPDT) ON-ON-ON	
2.	217-907	2	ROCKER SWITCH (DPDT) ON-ON	
3.	214-301	1	ACCESSORY SOCKET	
4.	215-128	1	HOUR METER	
5.	217-017	1	CONNECTOR (4-WAY, FM)	
6.	306-603	1	AUDIO ALARM	
7.	211-070	1	TACHOMETER (3000 RPM)	
8.	217-908	1	ROCKER SWITCH (ON-ON(ON),DPDT)	
9.	214-663	1	AT GAUGE HARNESS	

NOT SHOWN:

FOOTNOTES:

NOTE:

# ELECTRICAL DIAGRAM JT GAUGE HARNESS

TO WORK LIGHT HARNESS

JT GAUGE HARNESS

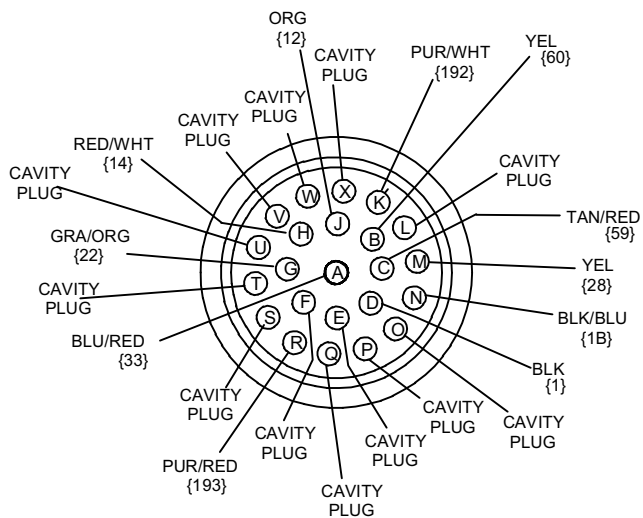
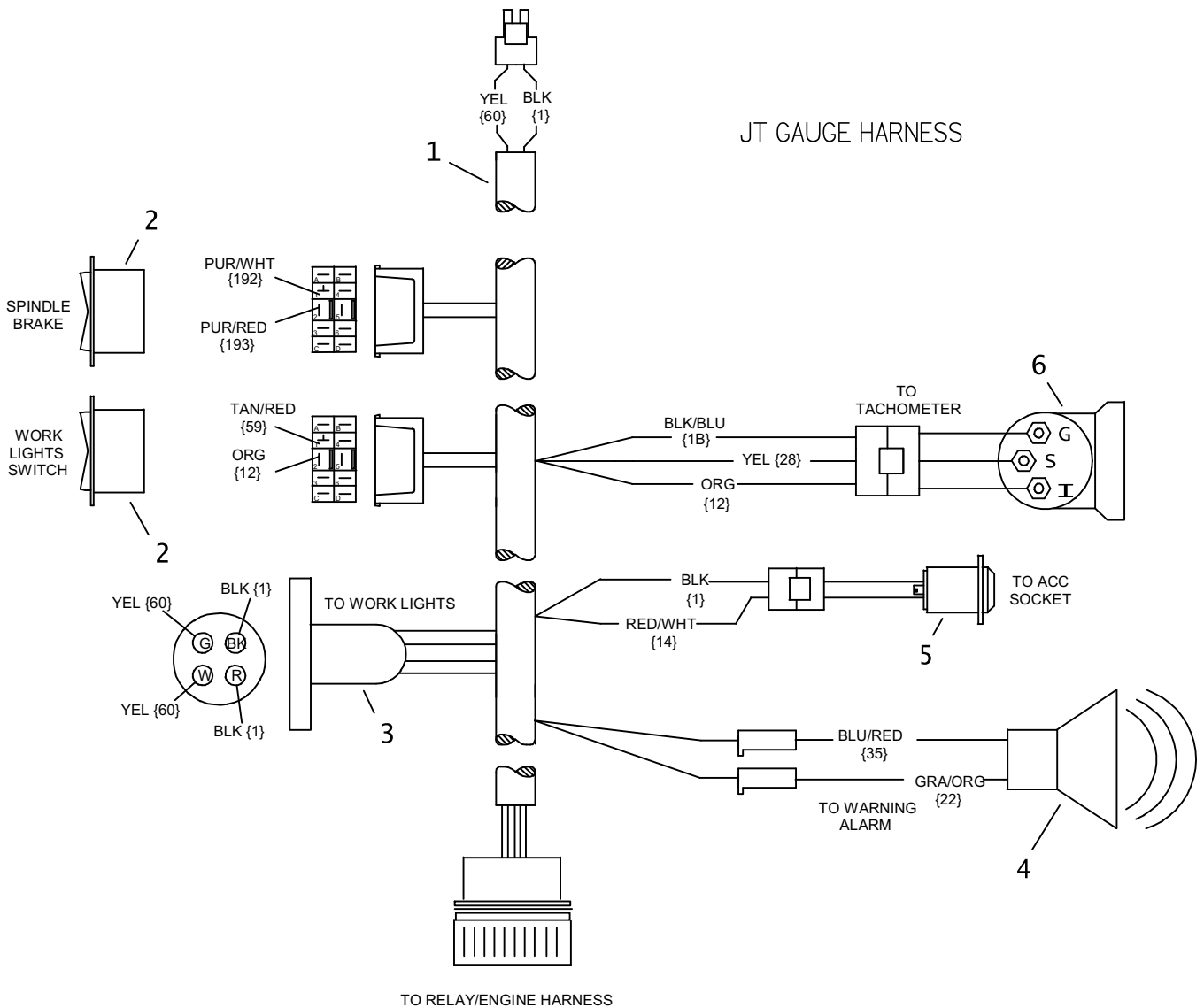

## ELECTRICAL DIAGRAM

### JT GAUGE HARNESS

REF NO.	PART NUMBER	QTY	DESCRIPTION	REMARKS
1.	214-620	1	HARNESS, GAUGE	
2.	217-907	2	ROCKER SWITCH (DPDT) ON-ON	
3.	217-017	1	CONNECTOR (4-WAY, FM)	
4.	306-603	1	AUDIO ALARM	
5.	214-301	1	ACCESSORY SOCKET	
6.	211-070	1	TACHOMETER (3000 RPM)	

NOT SHOWN:

FOOTNOTES:

NOTE:

# ELECTRICAL DIAGRAM VICE WRENCH SWITCH HARNESS

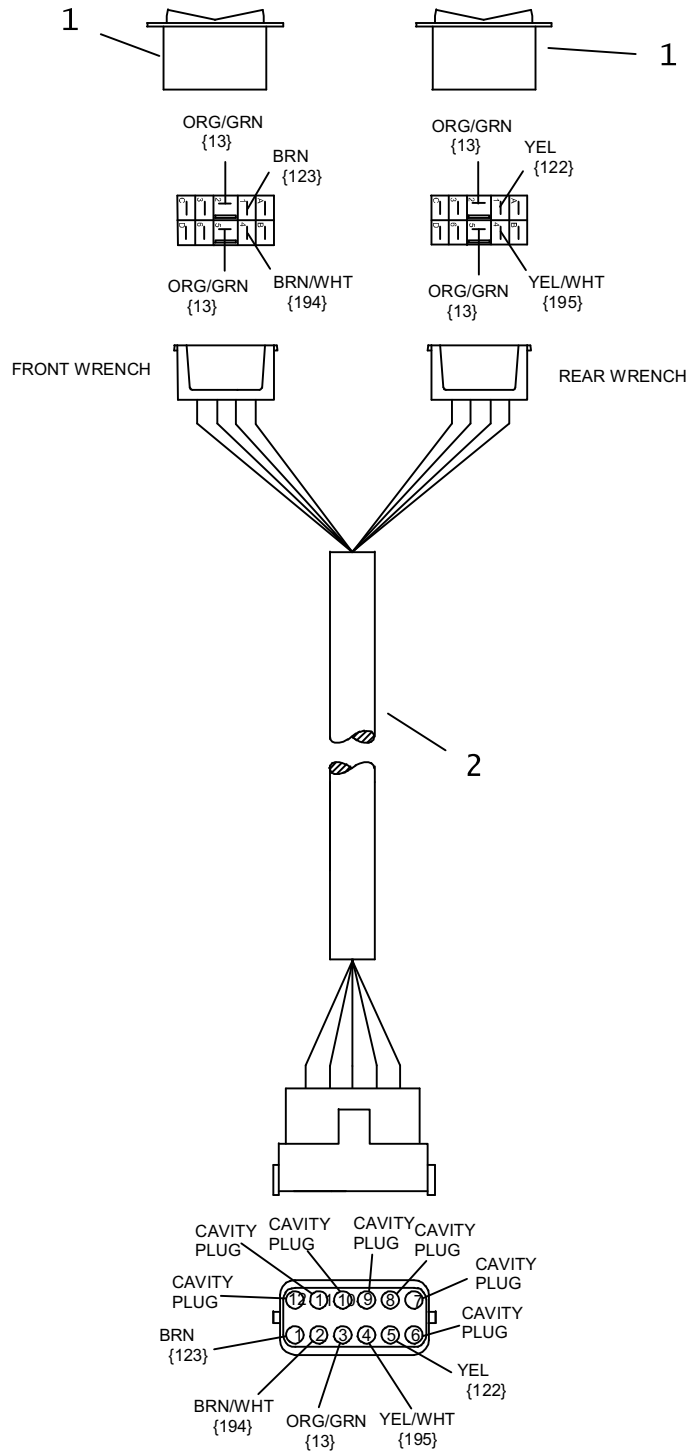

## ELECTRICAL DIAGRAM

### VICE WRENCH SWITCH HARNESS

REF NO.	PART NUMBER	QTY	DESCRIPTION	REMARKS
1.	217-908	2	ROCKER SWITCH (ON-ON(ON),DPDT)	
2.	214-712	1	JT27M1 WRENCH SWITCH HARNESS	

NOT SHOWN:

FOOTNOTES:

NOTE:

# ELECTRICAL DIAGRAM WORKLIGHT HARNESS

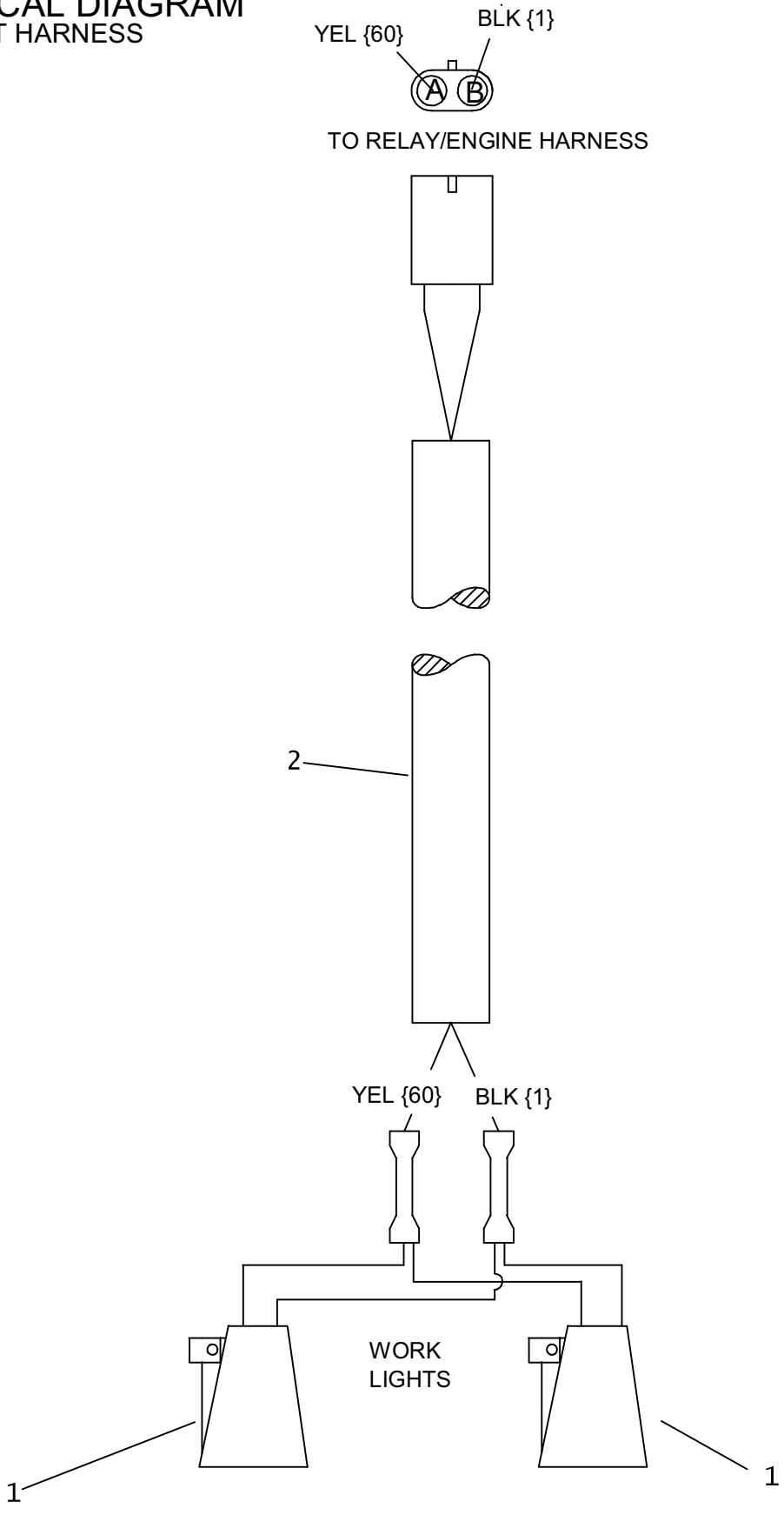

## ELECTRICAL DIAGRAM WORKLIGHT HARNESS

REF NO.	PART NUMBER	QTY	DESCRIPTION	REMARKS
1.	217-057	2	WORKING LIGHT - CLEAR	
2.	214-791	1	WORKLIGHT HARNESS	

NOT SHOWN:

FOOTNOTES:

NOTE:

# GROUNDING HARDWARE (ESS)

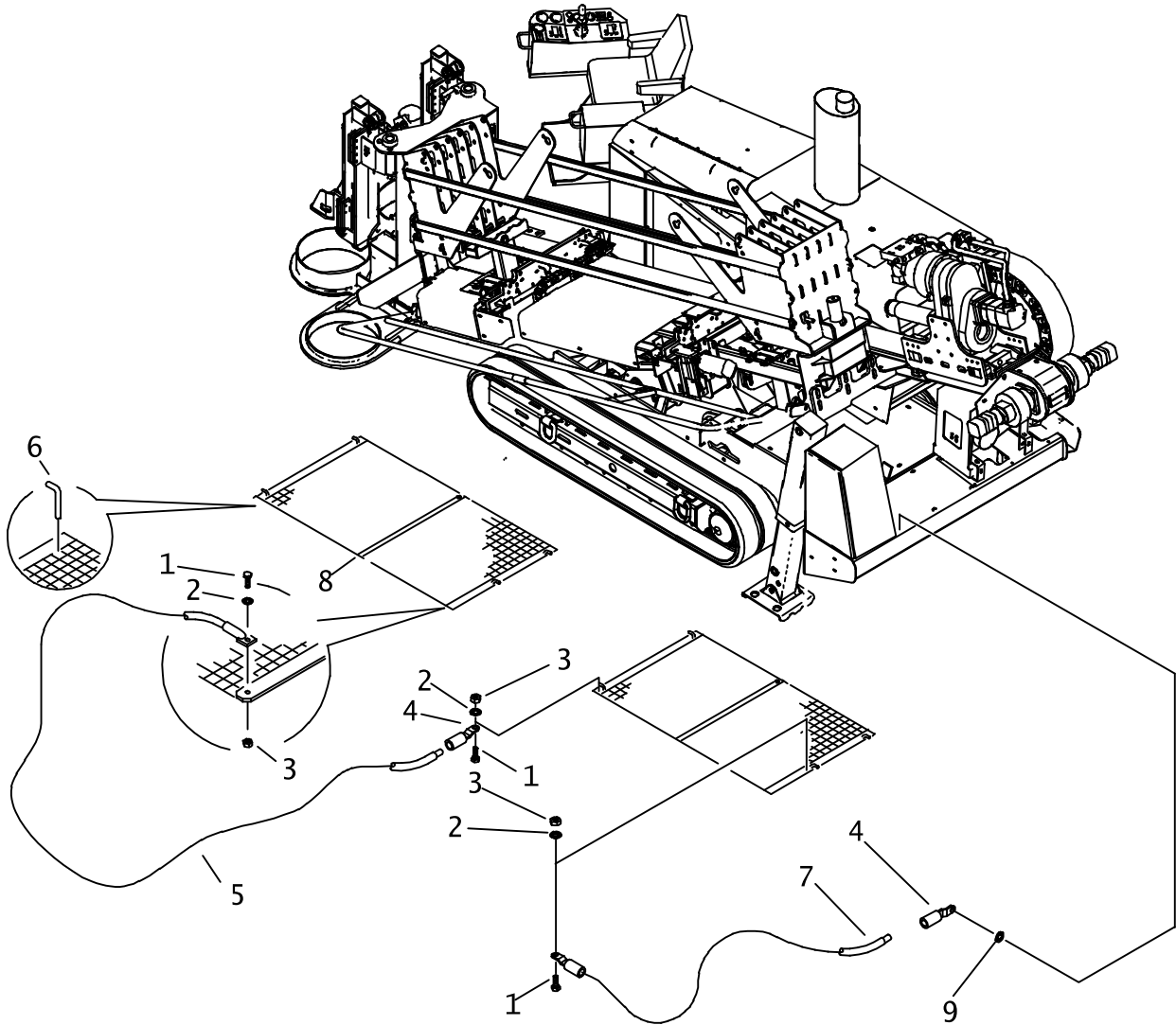



## GROUNDING HARDWARE (ESS)

REF NO.	PART NUMBER	QTY	DESCRIPTION	REMARKS
	100-074	-	STRIKE MAT KIT	
1.	106-217	3	BOLT (1/4-NC X 1", SIL BRZ)	
2.	106-221	3	INT STAR WASHER (1/4", SIL BRZ)	
3.	106-455	3	LOCKNUT (1/4-NC, SIL BRZ)	
4.	215-771	2	GROUND RECEPTACLE (.3125" FM)	
5.	215-827	1	GROUND CABLE (6 GA X 6' M-EYE)	
6.	183-658	8	MAT STAKE	
7.	215-790	1	GROUND CABLE (6GA X 20' M-EYE)	
8.	215-824	2	GRID (6')	
9.	105-895	1	LOCK WASHER (3/8")	

NOT SHOWN:

FOOTNOTES:

NOTE:

# COIL MOUNT

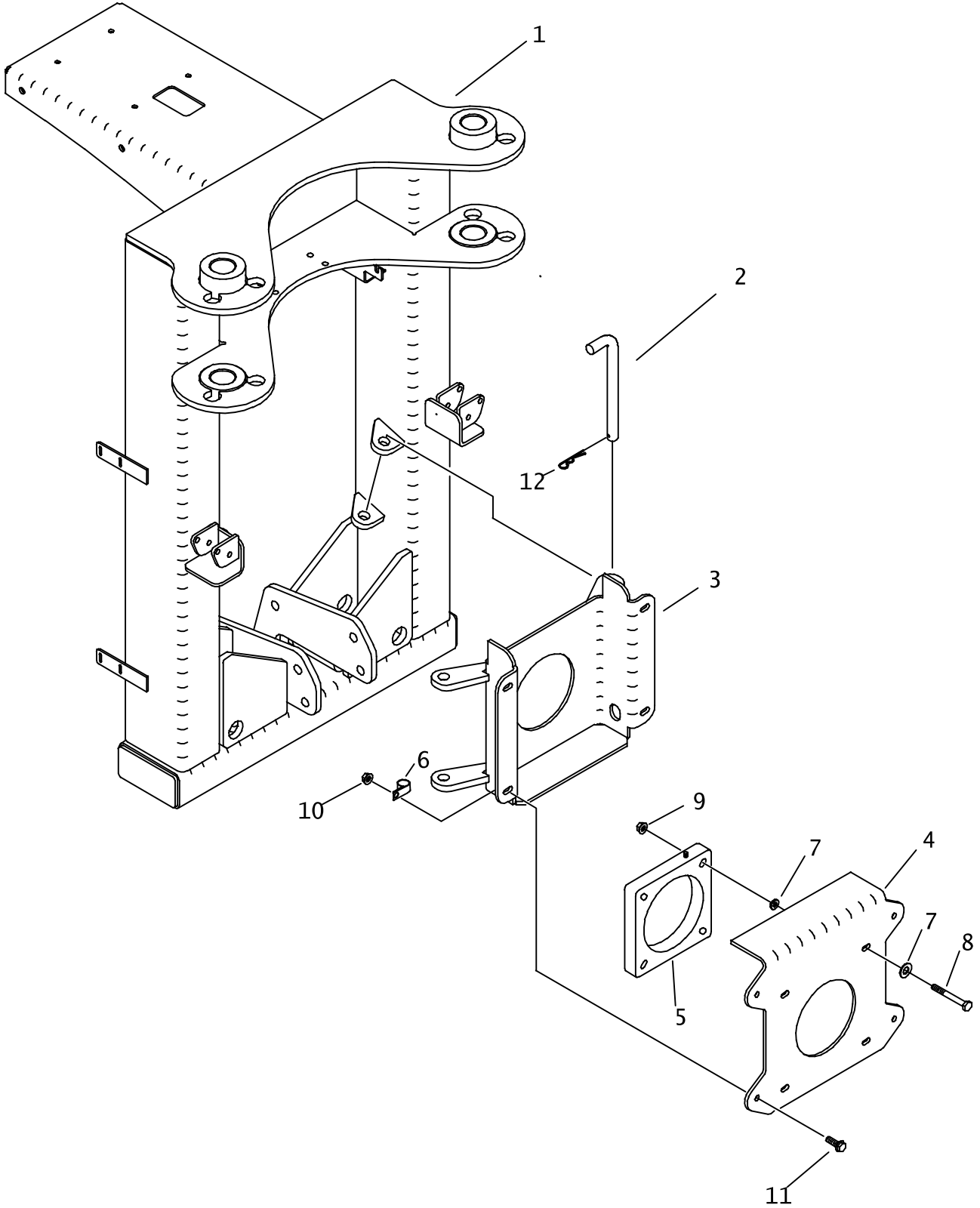

## COIL MOUNT

REF NO.	PART NUMBER	QTY	DESCRIPTION	REMARKS
1.	306-428	1	PIVOT FRAME	
2.	185-142	2	PIN	
3.	309-400	1	GUIDE PLATE	
4.	309-399	1	COVER PLATE	
5.	<u>216-063</u>	1	CURRENT TRANSFORMER	
	211-084	1	CURRENT TRANSFORMER	
6.	110-126	2	BOLT-ON CLAMP (1/2")	
7.	105-117	8	WASHER (5/16")	
8.	106-330	4	SCREW (M8-1.25 X 70MM)	
9.	106-561	4	LOCKNUT (M8-1.25, PRV TRQ, 10.9)	
10.	106-387	4	FLG LOCKNUT (M10-1.50)	
11.	106-724	4	FLG SCREW (M10-1.50 X 25MM)	
12.	110-128	2	SPRING CLIP PIN (5/32" X 1")	

### FOOTNOTES

NOT SHOWN  
214-550 1 CURRENT COIL CABLE

NOTE:

## ELECTRIC STRIKE SYSTEM

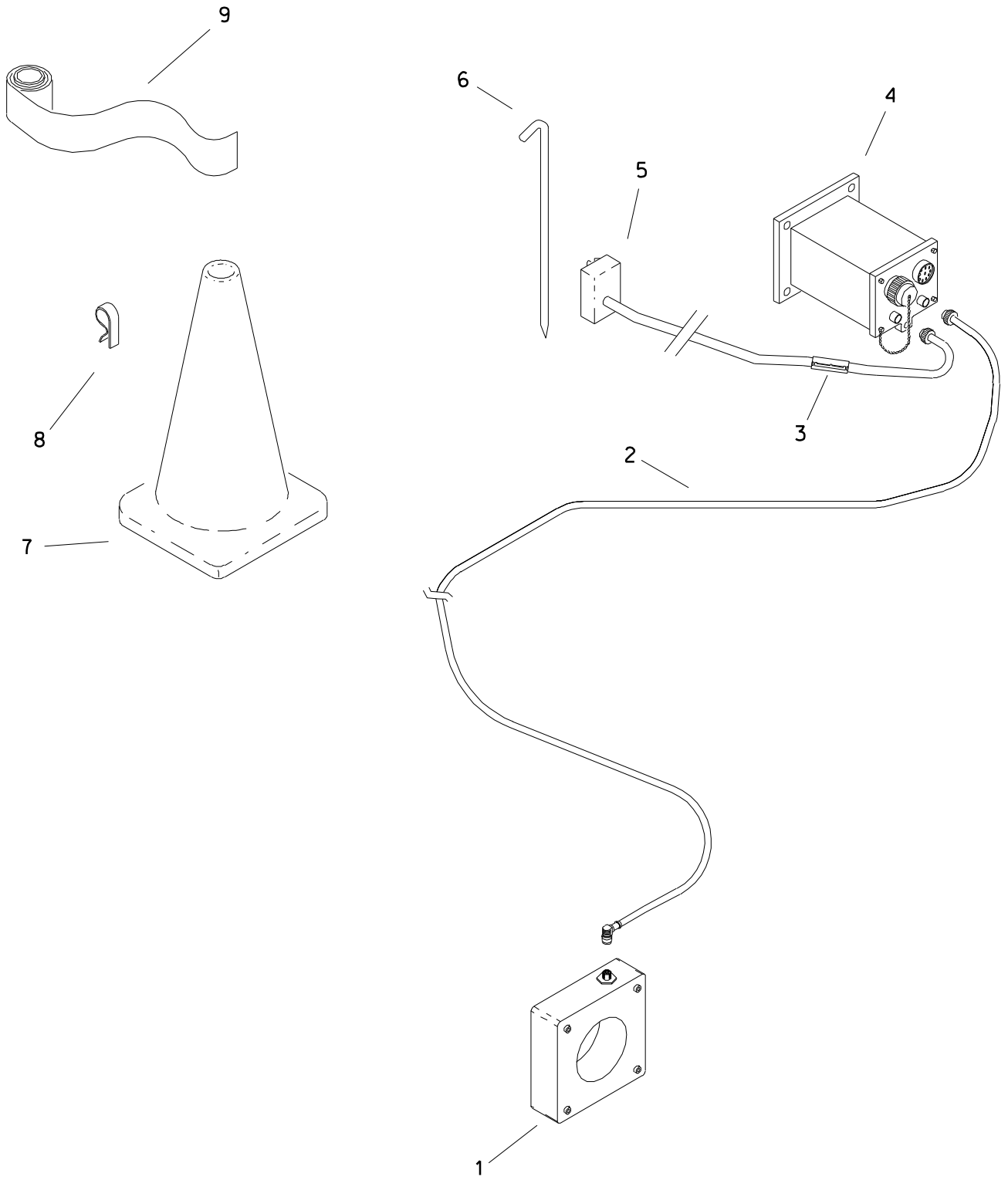

# ELECTRIC STRIKE SYSTEM

REF NO.	PART NUMBER	QTY	DESCRIPTION	REMARKS
1.	216-063	-	CURRENT TRANSFORMER	
2.	214-550	1	CURRENT COIL CABLE	
3.	217-331	1	SMALL FERRITE CLAMP-ON	
4.	217-241	-	ESID MODULE NEW (T)	
5.	211-042	1	VOLTAGE LIMITER CABLE	
6.	215-799	1	VOLTAGE STAKE	
7.	259-210	8	TRAFFIC CONE - ORANGE	
8.	259-234	8	CONE CLIP	
9.	260-223	1	BARRIER TAPE (3" X 1000')	

FOOTNOTES

# GROUND DRIVE CONTROL

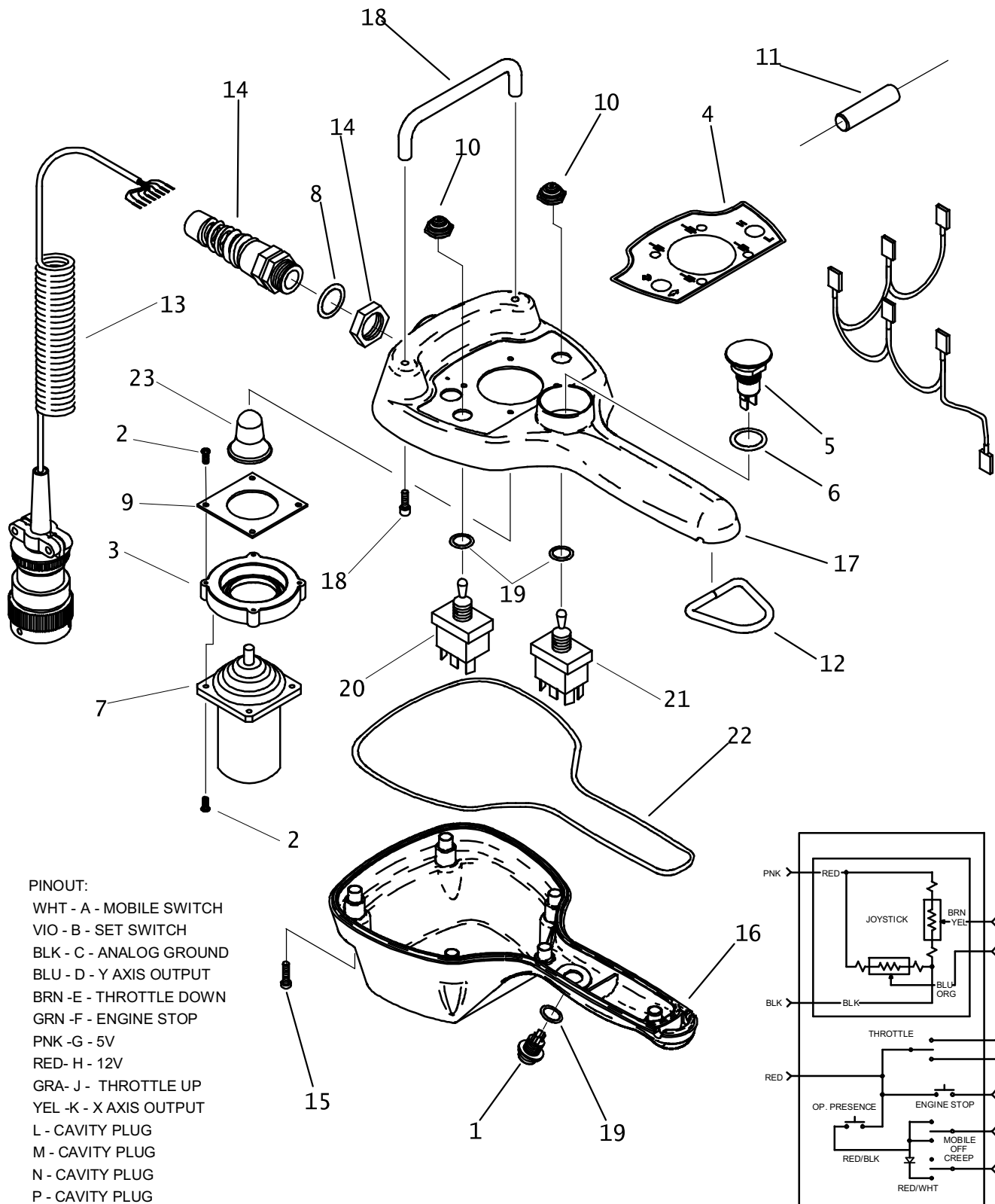

- PINOUT:
- WHT - A - MOBILE SWITCH
  - VIO - B - SET SWITCH
  - BLK - C - ANALOG GROUND
  - BLU - D - Y AXIS OUTPUT
  - BRN - E - THROTTLE DOWN
  - GRN - F - ENGINE STOP
  - PNK - G - 5V
  - RED - H - 12V
  - GRA - J - THROTTLE UP
  - YEL - K - X AXIS OUTPUT
  - L - CAVITY PLUG
  - M - CAVITY PLUG
  - N - CAVITY PLUG
  - P - CAVITY PLUG

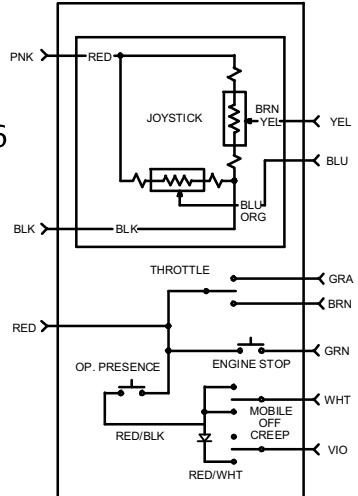

## GROUND DRIVE CONTROL

REF NO.	PART NUMBER	QTY	DESCRIPTION	REMARKS
	214-589		GROUND DRIVE CONTROL	
1.	214-614	1	PUSH BUTTON SWITCH (SPST) OFF-ON	
2.	106-820	8	SCREW, SELF TAPPING (3.0 X 12MM)	
3.	305-664	1	JOY STICK ADAPTER	
4.	274-998	1	DECAL	
5.	214-615	1	KILL SWITCH	
6.	157-040	1	O-RING (-016 D90)	
7.	214-613	1	JOYSTICK ASSEMBLY	SEE FOOTNOTE 1
	215-1394	1	JOYSTICK ASSEMBLY	SEE FOOTNOTE 1
8.	157-017	1	O-RING (.018 D90)	
9.	149-558	1	JOYSTICK GASKET	
10.	214-728	2	TOGGLE SWITCH HALF BOOT (SEAL)	
11.	215-1720	1	DIODE IN5402	
12.	105-775	1	D-RING	
13.	211-020	1	COILED CORD-MALE	
14.	211-021	1	STRAIN RELIEF	
15.	106-876	6	SCREW	
16.	214-497	1	LOWER HOUSING	
17.	214-498	1	UPPER HOUSING	
18.	116-933	1	HANDLE	
	106-894	2	SCREW (#8-32 X 1" PLPS SSI)	SEE FOOTNOTE 2
19.	157-039	2	O-RING (-014 D90)	
20.	217-896	1	TOGGLE SWITCH	
21.	214-570	1	TOGGLE SWITCH (DPDT) ON-OFF-ON	
22.	116-549	AR	ROPE GASKET ( USE 27" )	
23.	116-932	1	JOYSTICK KNOB	

NOT SHOWN:

### FOOTNOTES:

- I. JOYSTICK SHOULD BE ORIENTED WITH LABEL POINTING TOWARDS CABLE END. (REV G)
- I. JOYSTICK SHOULD BE ORIENTED WITH X+ ON LABEL POINTING TOWARDS CABLE END. (REV H)  
 Y-AXIS OUTPUT: 3.75V FORWARD 1.25V BACK  
 X-AXIS OUTPUT: 3.75V LEFT 1.25V RIGHT

2. APPLY THREAD LOCKING COMPOUND TO BOTH HANDLE SCREWS.

NOTE:





# **ANCHOR SYSTEMS**

## ANCHOR PIVOT FRAME

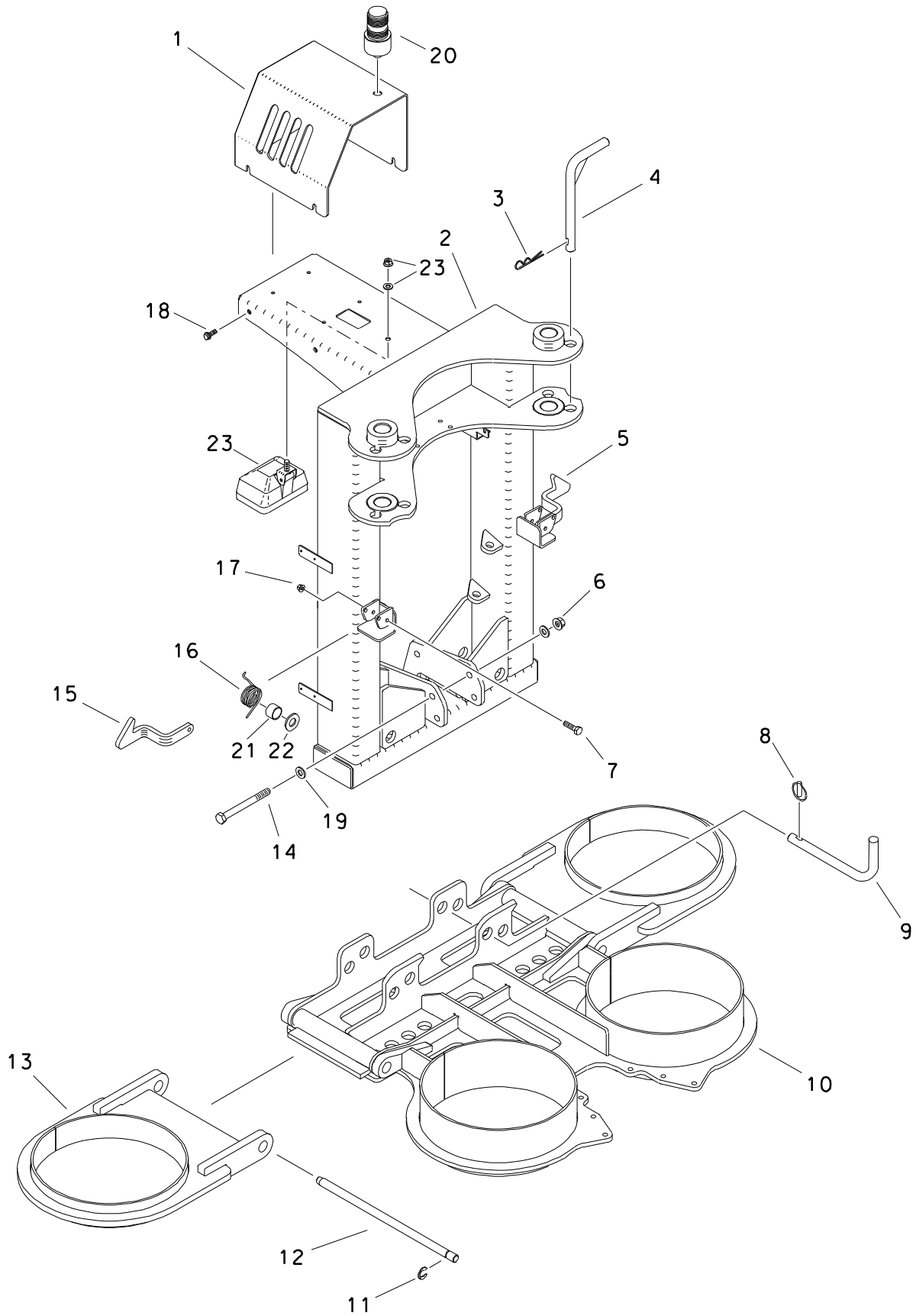

## ANCHOR PIVOT FRAME

REF NO.	PART NUMBER	QTY	DESCRIPTION	REMARKS
1.	309-254	1	VALVE COVER	
2.	306-428	1	PIVOT FRAME	
3.	110-128	2	SPRING CLIP PIN (5/32" X 1")	
4.	350-516	2	PIN	
5.	343-311	1	ANCHOR PIVOT LATCH (RIGHT)	
6.	106-442	4	FLG LOCKNUT (M16-2.00, PRV TRQ)	
7.	106-332	4	SCREW (M10-1.50 X 70MM)	
8.	110-228	2	LYNCH PIN (7/16" X 2")	
9.	343-445	2	PIN (31.75MM X 262MM)	
10.	313-592	1	ANCHOR BASE	
11.	115-483	4	KLIP RING (1.250")	
12.	184-973	2	PIN	
13.	343-548	2	PIVOT	
14.	106-612	4	SCREW (M16-2.00 X 180MM, 10.9)	
15.	343-312	1	ANCHOR PIVOT LATCH (LEFT)	
16.	115-580	2	TORSION SPRING	
17.	105-894	4	LOCKNUT (M10-1.50, PRV TRQ, 10.9)	
18.	106-383	4	FLG LK SCREW (M10-1.50 X 30MM)	
19.	106-398	8	WASHER (M16, HARDENED)	
20.	214-697	1	GREEN STROBE LIGHT	
	217-297	1	STROBE LIGHT GREEN MED PROFILE	
	214-103	1	2-WAY MALE CONNECTOR	
	214-991	-	REPLACEMENT FLASH TUBE	
	217-303	-	REPLACEMENT LENS (GREEN)	
	157-645	2	WEATHER-PAC SEAL (2.80MM)	
	214-104	2	PACKARD MALE TERMINAL	
	217-301	-	BRUSH GUARD	
21.	343-270	1	SLEEVE	
22.	105-118	2	WASHER (3/8")	
23.	217-007	1	WORKING LIGHT (CLEAR, RECT)	

## FOOTNOTES

# LEFT AUGER ANCHOR DRIVE

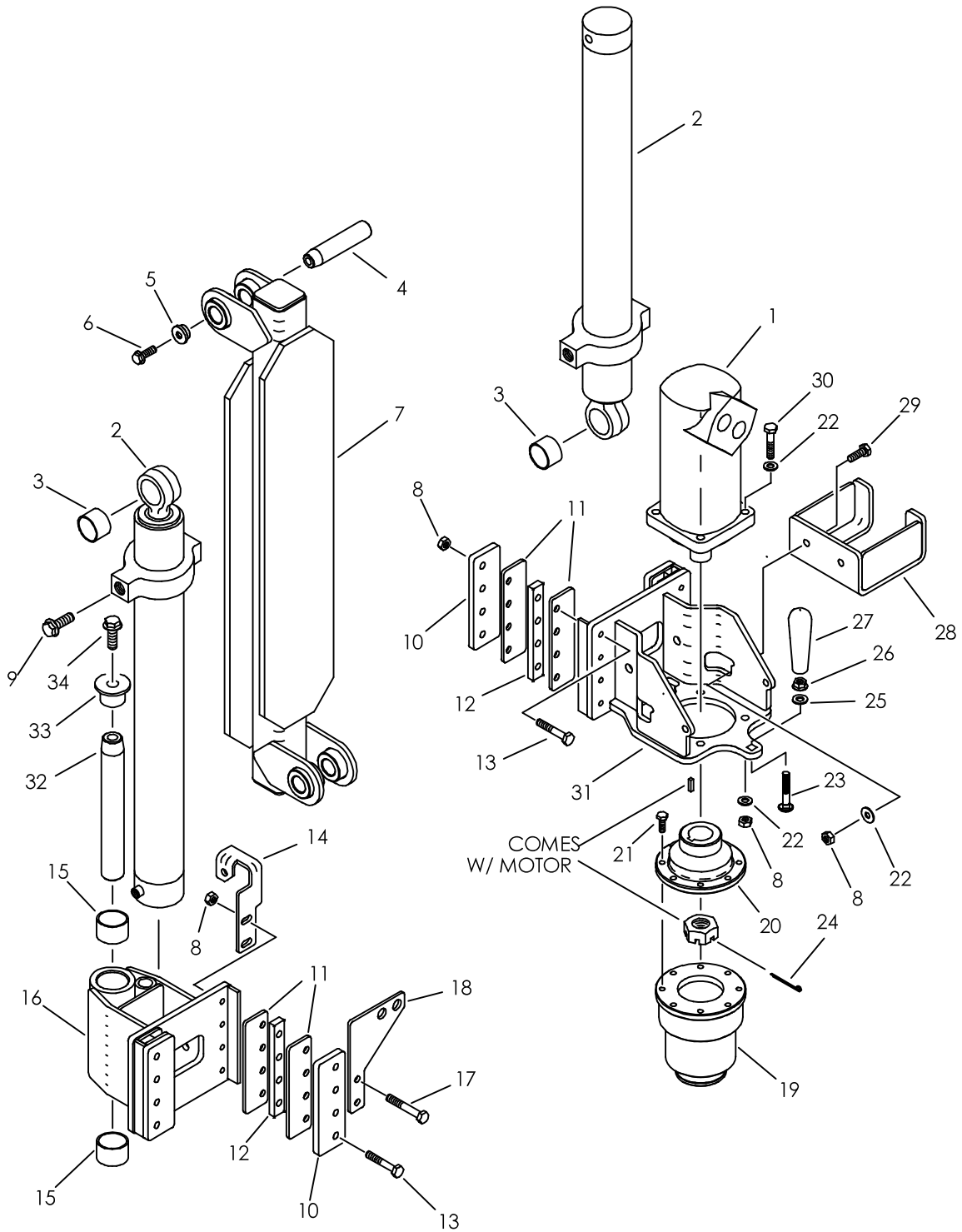

## LEFT AUGER ANCHOR DRIVE

REF NO.	PART NUMBER	QTY	DESCRIPTION	REMARKS
1.	149-895	1	HYD MOTOR	
	500-390		SEAL REPAIR KIT - REAR	
	500-391		SEAL REPAIR KIT - SHAFT	
	502-177		SHAFT AND BEARING ASS'Y	
	107-792		BOLT (5/16" X 1-5/8", DBL HEX)	
	165-900		KEY (7/16" SQ X 1.250")	
	105-917		CASTLE NUT (1-1/4-NF)	SEE FOOTNOTE 1
	500-2123		FRONT RETAINER (ANCHOR MOTOR)	
2.	150-747	2	CYLINDER ASSEMBLY	
3.	125-771	2	COMPOSITION BUSHING (1.25")	
4.	183-765	2	TAPERED PIN (31.7MM X 110MM)	
5.	181-982	2	TAPERED INSERT (1.25")	
6.	106-469	2	FLG SCREW (M12-1.75 X 30MM)	USE LOCTITE 242
7.	359-799	1	MAST	
8.	106-685	23	LOCKNUT(M12-1.75,PRV TRQ,10.9)	
9.	106-471	4	FLG SCREW (M16-2.00 X 30MM)	USE LOCTITE 242
10.	309-194	4	CLAMP PLATE	
11.	309-195	8	GLIDE STRIP	
12.	309-203	4	CARRIAGE SPACER BAR	
13.	106-335	14	SCREW (M12-1.75 X 70MM)	
14.	309-206	1	BULKHEAD PLATE	
15.	125-773	2	COMPOSITION BUSHING (1.75")	
16.	309-209	1	ARM	
17.	106-700	2	SCREW (M12-1.75 X 80MM)	
18.	309-204	1	BULKHEAD PLATE	
19.	309-582	-	FLANGED HEX DRIVER	
20.	178-881	1	FLANGE	
21.	105-245	8	SCREW (M10-1.50 X 25MM)	USE LOCTITE 242
22.	106-397	9	WASHER (M12, HARDENED)	
23.	105-279	1	CARRIAGE BOLT (1/2-NC X 3")	
24.	105-501	1	COTTER PIN (1/8" X 2")	
25.	105-071	1	WASHER (1/2")	
26.	105-833	1	FLG LOCKNUT (1/2-NC)	
27.	110-531	1	HANDLE (1/2-NC, BLACK)	USE LOCTITE 242
28.	309-602	1	ANCHOR HANGER	
29.	106-333	2	SCREW (M12-1.75 X 40MM, 8.8)	
30.	106-594	4	SCREW (M12-1.75 X 60MM)	
31.	309-207	1	MOTOR MOUNT	
32.	179-239	1	TAPERED PIN (44.4MM X 288MM)	
33.	181-975	1	TAPERED INSERT (1.75")	
34.	106-470	1	FLG SCREW (M16-2.00 X 40MM)	USE LOCTITE 242

NOT SHOWN:

FOOTNOTES:

1. TORQUE NUT TO 375 FT. LB. DRY OR 275 FT. LB. LUBED

NOTE:

# RIGHT AUGER ANCHOR DRIVE

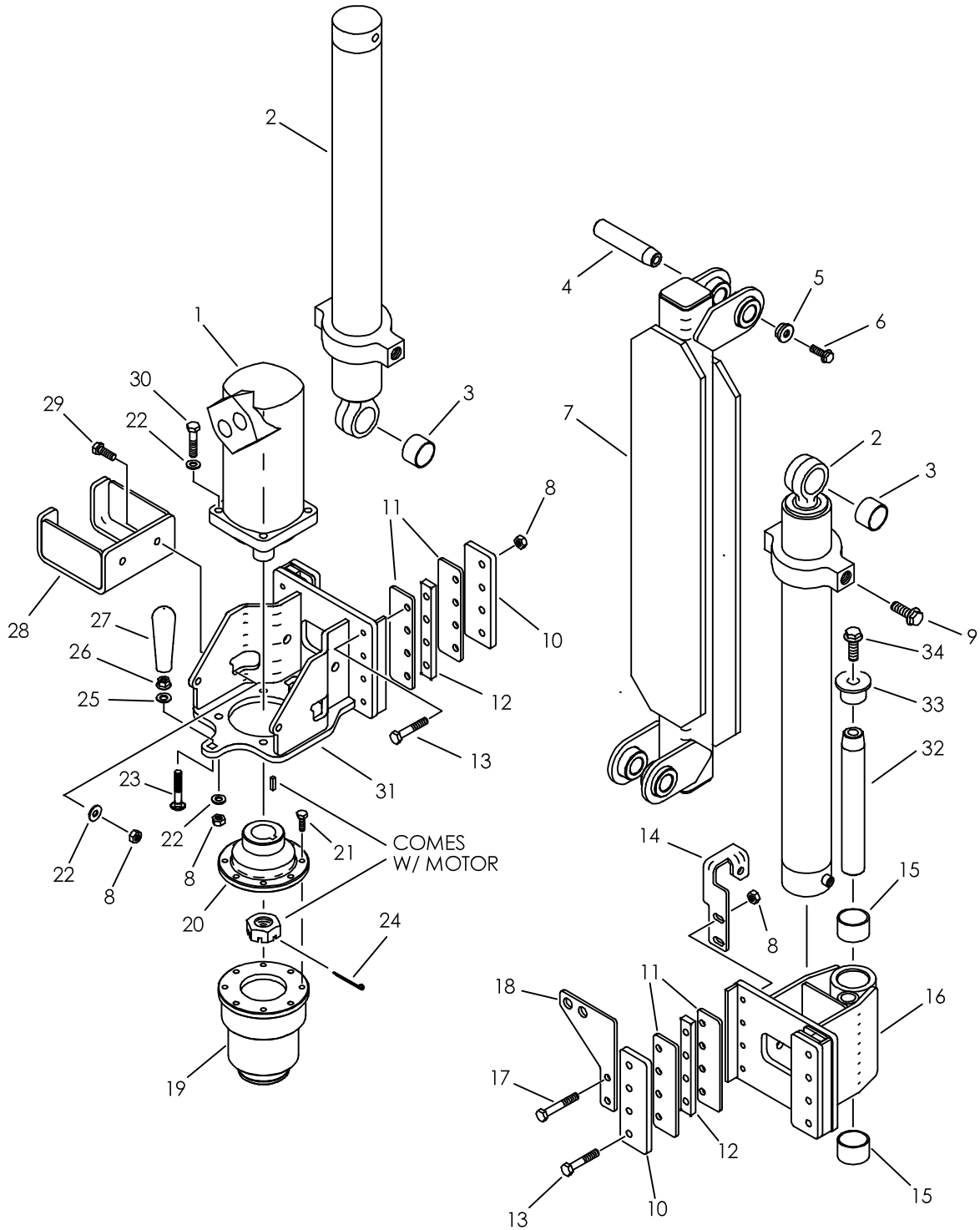

## RIGHT AUGER ANCHOR DRIVE

REF NO.	PART NUMBER	QTY	DESCRIPTION	REMARKS
1.	149-895	1	HYD MOTOR	
	500-390		SEAL REPAIR KIT - REAR	
	500-391		SEAL REPAIR KIT - SHAFT	
	502-177		SHAFT AND BEARING ASS'Y	
	107-792		BOLT (5/16"X 1-5/8", DBL HEX)	
	165-900		KEY (7/16" SQ X 1.250")	
	105-917		CASTLE NUT (1-1/4-NF)	SEE FOOTNOTE 1
	500-2123		FRONT RETAINER (ANCHOR MOTOR)	
2.	150-747	2	CYLINDER ASSEMBLY	
3.	125-771	2	COMPOSITION BUSHING (1.25")	
4.	183-765	2	TAPERED PIN (31.7MM X 110MM)	
5.	181-982	2	TAPERED INSERT (1.25")	
6.	106-469	2	FLG SCREW (M12-1.75 X 30MM)	USE LOCTITE 242
7.	359-799	1	MAST	
8.	106-685	23	LOCKNUT(M12-1.75,PRV TRQ,10.9)	
9.	106-471	4	FLG SCREW (M16-2.00 X 30MM)	USE LOCTITE 242
10.	309-194	4	CLAMP PLATE	
11.	309-195	8	GLIDE STRIP	
12.	309-203	4	CARRIAGE SPACER BAR	
13.	106-335	14	SCREW (M12-1.75 X 70MM)	
14.	309-205	1	BULKHEAD PLATE	
15.	125-773	2	COMPOSITION BUSHING (1.75")	
16.	309-209	1	ARM	
17.	106-700	2	SCREW (M12-1.75 X 80MM)	
18.	309-204	1	BULKHEAD PLATE	
19.	309-582	-	FLANGED HEX DRIVER	
20.	178-881	1	FLANGE	
21.	105-245	8	SCREW (M10-1.50 X 25MM)	USE LOCTITE 242
22.	106-397	9	WASHER (M12, HARDENED)	
23.	105-279	1	CARRIAGE BOLT (1/2-NC X 3")	
24.	105-501	1	COTTER PIN (1/8" X 2")	
25.	105-071	1	WASHER (1/2")	
26.	105-833	1	FLG LOCKNUT (1/2-NC)	
27.	110-531	1	HANDLE (1/2-NC, BLACK)	USE LOCTITE 242
28.	309-602	1	ANCHOR HANGER	
29.	106-333	2	SCREW (M12-1.75 X 40MM, 8.8)	
30.	106-594	4	SCREW (M12-1.75 X 60MM)	
31.	309-207	1	MOTOR MOUNT	
32.	179-239	1	TAPERED PIN (44.4MM X 288MM)	
33.	181-975	1	TAPERED INSERT (1.75")	
34.	106-470	1	FLG SCREW (M16-2.00 X 40MM)	USE LOCTITE 242

NOT SHOWN:

FOOTNOTES:

- I. TORQUE NUT TO 375 FT. LB. DRY OR 275 FT. LB. LUBED

NOTE:

# FLANGED HEX DRIVER ASS'Y

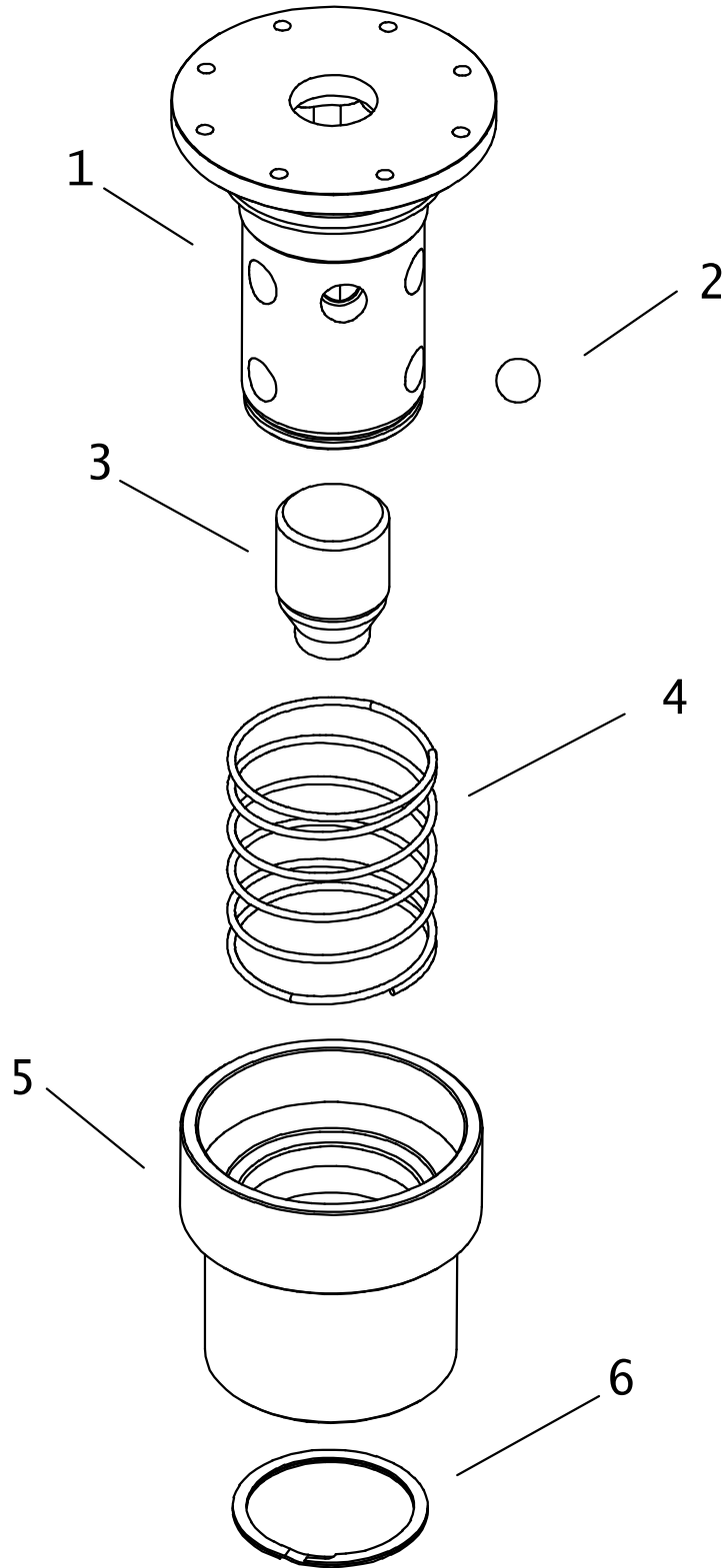



## FLANGED HEX DRIVER ASS'Y

REF NO.	PART NUMBER	QTY	DESCRIPTION	REMARKS
	309-582		FLANGED HEX DRIVER	INCLUDEDS REF NO. 1-6
1.	309-093	1	ANCHOR DRIVER	FOOTNOTE 2
2.	125-150	9	DETENT BALL (.875")	
3.	309-095	1	WEIGHT STOP	
4.	117-160	1	COMPRESSION RING	
5.	178-591	1	LOCK COLLAR	
6.	118-054	1	EXTERNAL SNAP RING	
	116-761	1	SPIRAL RETAINING RING	FOOTNOTE 1

NOT SHOWN:

FOOTNOTES:

1. USE WHEN INSTALLING UPDATED 309-093
2. UPDATED VERSION NECKED-DOWN FOR THICKER 116-761

NOTE:

# ANCHOR

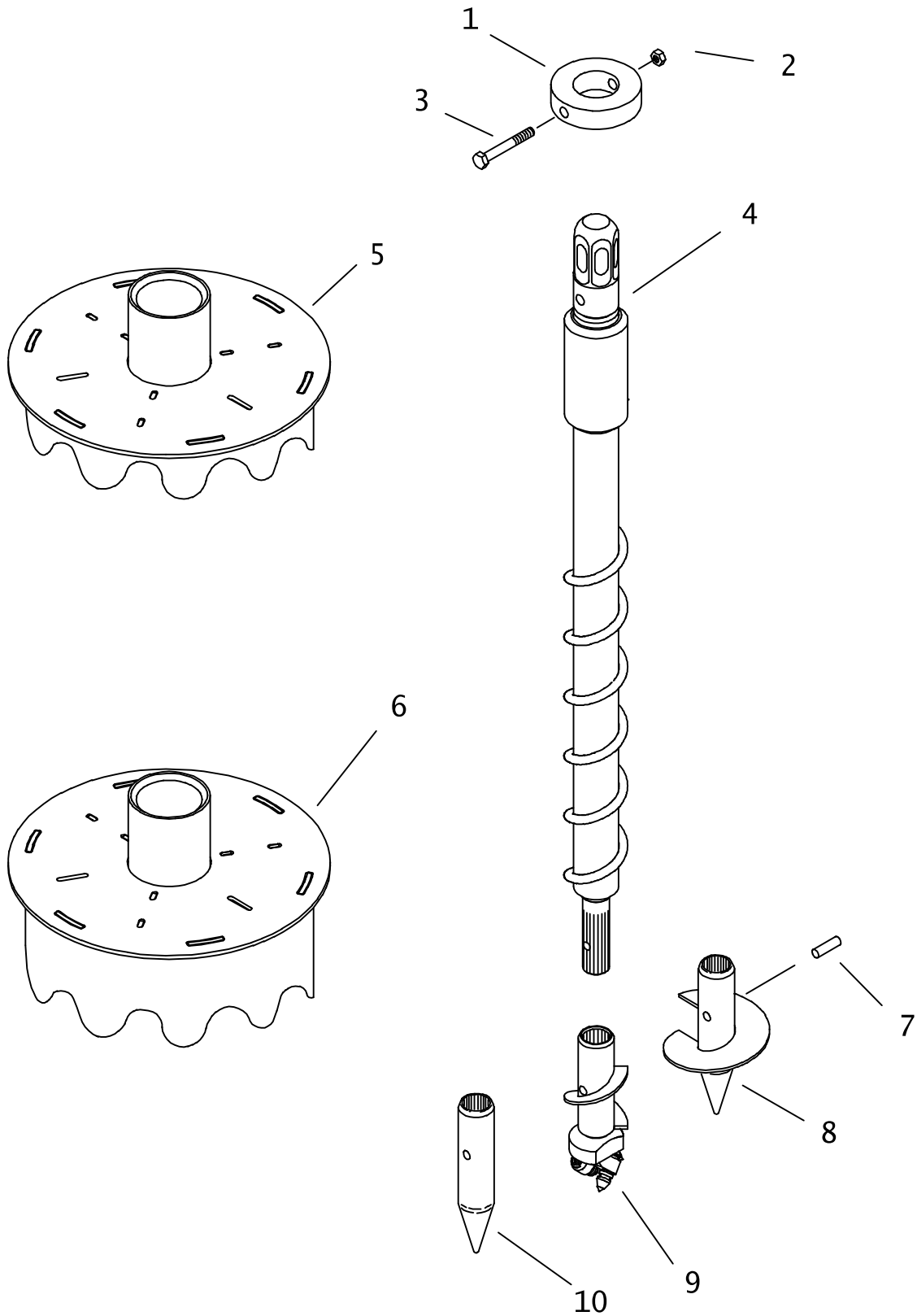

# ANCHOR

REF NO.	PART NUMBER	QTY	DESCRIPTION	REMARKS
	309-250	-	ANCHOR SHAFT	INCL REF NO'S 1-4
1.	178-513	1	COLLAR	
2.	106-685	1	LOCKNUT(M12-1.75,PRV TRQ,10.9)	
3.	106-645	1	SCREW (M12-1.75 X 110MM, 10.9)	
4.	308-902	1	ANCHOR STAKE	
5.	309-750	1	CENTERING CAP	SHORT - USED IN SIDE POSITIONS
6.	308-903	1	CENTERING CAP	TALL - USED IN FRONT POSITIONS
7.	183-860	AR	ROLL PIN (1/2" X 1-7/8")	
8.	356-366	AR	AUGER (150MM}	
	356-365	AR	AUGER (225MM)	
	356-364	AR	AUGER (380MM)	
9.	369-438	AR	3.5" CAP ANCHOR BIT	ROCK BITS
	136-113	-	INSERT BIT - CARBIDE TIPPED	REPLACEMENT BIT FOR 369-438
	131-259	-	INSERT BIT- CARBIDE TIPPED	
	136-112	-	CLIP RETAINER	REPLACEMENT CLIP FOR 369-438
10.	357-330	AR	STAKE POINT	DIRT BITS

NOT SHOWN:

FOOTNOTES:

NOTE:

# ANCHOR VALVE PRESSURE & RETURN HYDRAULICS

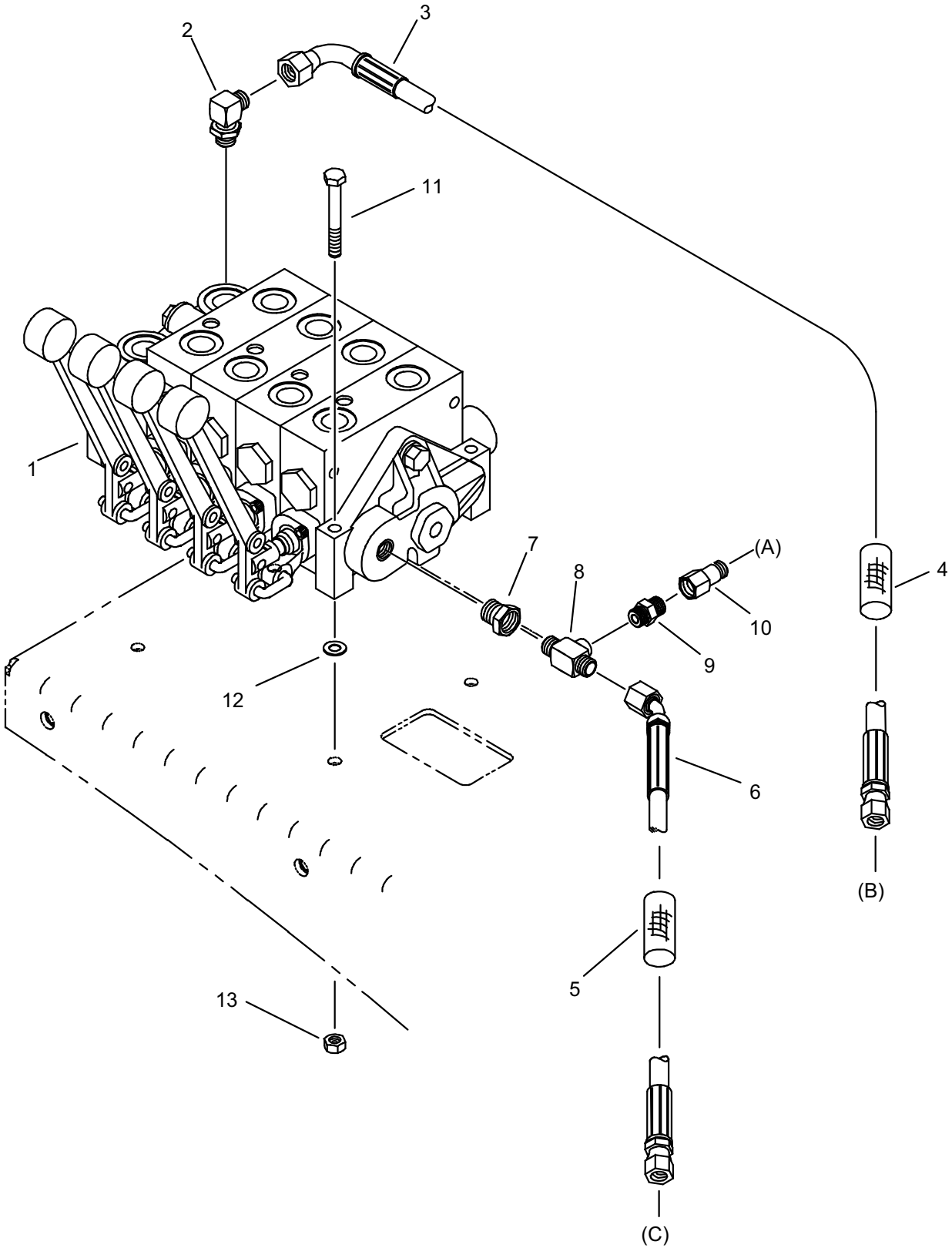

## ANCHOR VALVE PRESSURE & RETURN HYDRAULICS

REF NO.	PART NUMBER	QTY	DESCRIPTION	REMARKS
1.	158-064	1	HYD CONTROL VALVE (4-SPOOL)	
2.	154-300	1	CONNECTOR (100-12S90)	
3.	515-579	1	HOSE (100FX90S-104"-3000)	
4.	117-204	1	ABRASION SLEEVE (1.59" X 108")	
5.	115-924	1	ABRASION SLEEVE (1.59" X 88")	
6.	153-070	1	HOSE (100FX45-85"-3000)	
7.	510-017	1	REDUCER (12S-10SF)	
8.	154-458	1	RUN TEE (10S-100-06SF)	
9.	159-381	1	CHECK VALVE (06S-060)	
10.	154-373	1	REDUCER (040-060F)	
11.	106-330	3	SCREW (M8-1.25 X 70MM)	
12.	106-389	3	WASHER (M8)	
13.	106-561	3	LOCKNUT (M8-1.25, PRV TRQ, 10.9)	

NOT SHOWN:

FOOTNOTES:

- (A) CONNECTS W/ RETURN OIL FROM GREASER PUMP
- (B) TEE'S W/ FRONT WRENCH PRESSURE VALVE
- (C) TEE'S W/ FRONT WRENCH RETURN VALVE

NOTE:

REFER TO O-RING CHART (800-301) IN BACK OF BOOK FOR REPLACEMENT OF O-RINGS

# LEFT ANCHOR MOTOR HYDRAULICS

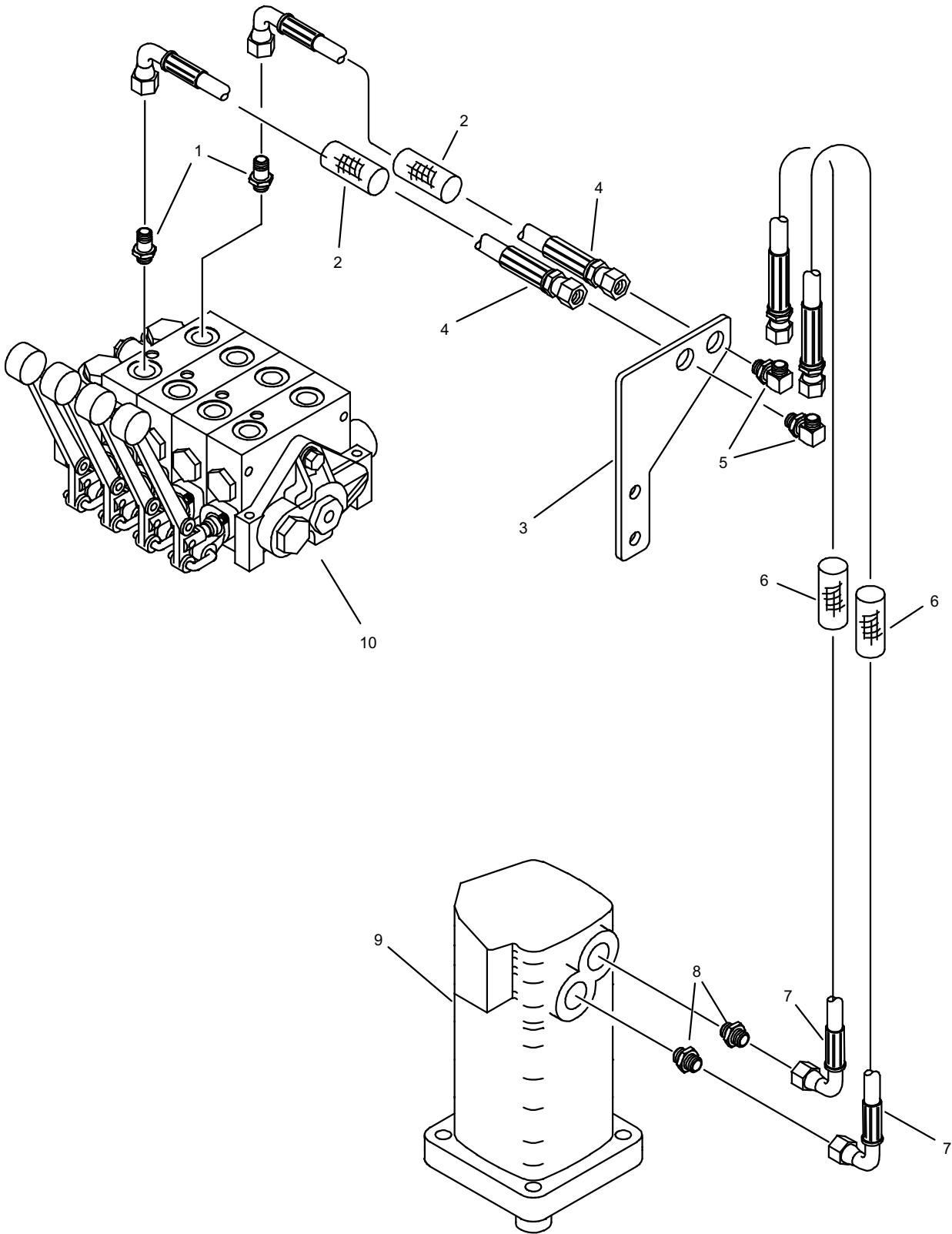

## LEFT ANCHOR MOTOR HYDRAULICS

REF NO.	PART NUMBER	QTY	DESCRIPTION	REMARKS
1.	154-438	2	CONNECTOR (08S-080, LG)	
2.	117-388	2	ABRASION SLEEVE (1.25" X 42")	
3.	309-204	1	BULKHEAD PLATE	
4.	515-718	2	HOSE (080FX90S-42"-3000)	
5.	154-396	2	BK CONNECTOR (080-08090BK)	
6.	117-324	2	ABRASION SLEEVE (1.25" X 48")	
7.	154-716	2	HOSE (080FX90-48"-3000)	
8.	154-307	2	CONNECTOR (16S-080)	
9.	149-895	-	HYD MOTOR	
	500-390		SEAL REPAIR KIT - REAR	
	500-391		SEAL REPAIR KIT - SHAFT	
	107-792		BOLT (5/16"X 1-5/8", DBL HEX)	
	165-900		KEY (7/16" SQ X 1.250")	
	105-917		CASTLE NUT (1-1/4-NF)	
10.	158-064	-	HYD CONTROL VALVE (4-SPOOL)	

NOT SHOWN:

FOOTNOTES:

NOTE:

REFER TO O-RING CHART (800-301) IN BACK OF THE BOOK FOR REPLACEMENT OF O-RINGS.

# RIGHT ANCHOR MOTOR HYDRAULICS

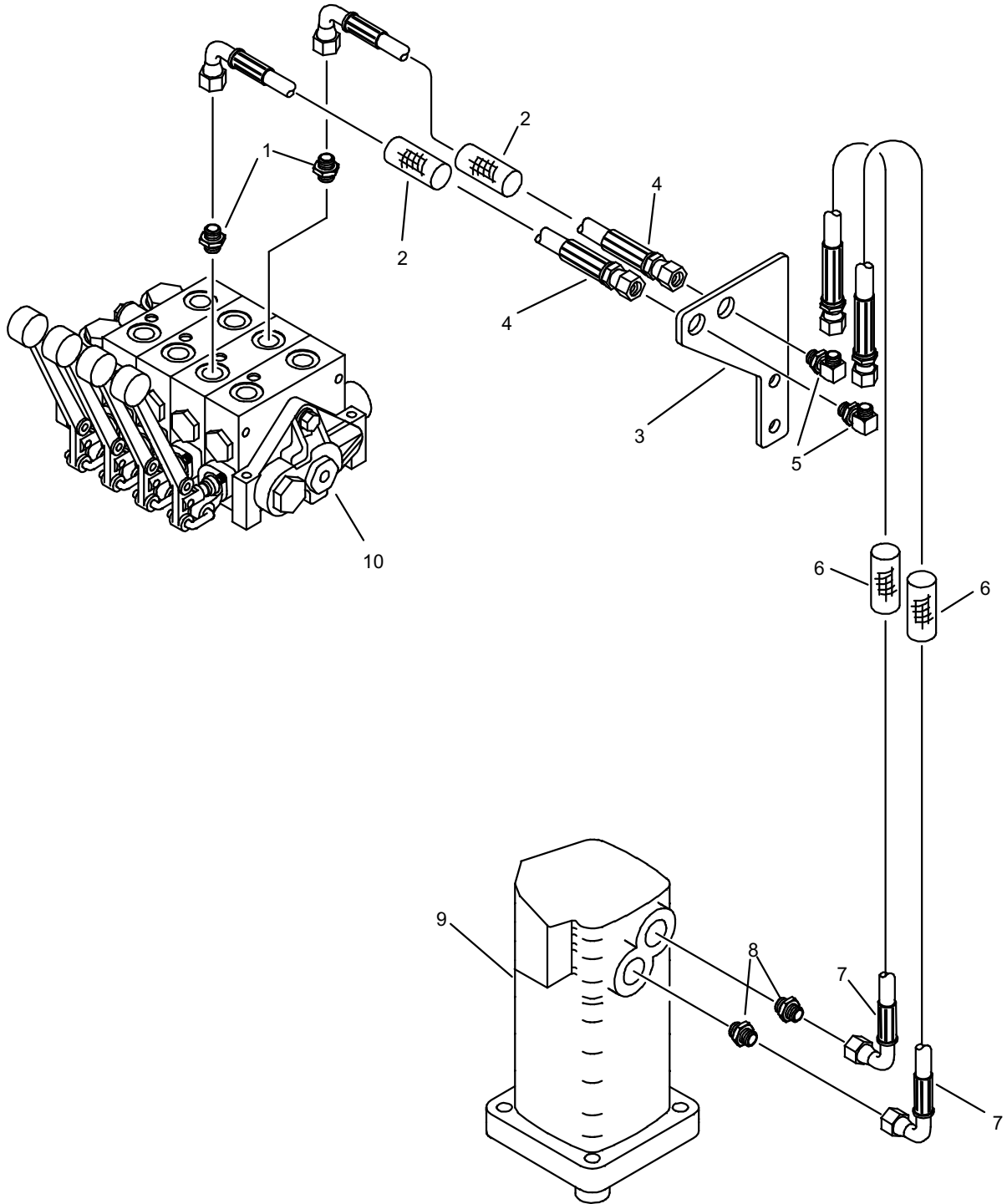



## RIGHT ANCHOR MOTOR HYDRAULICS

REF NO.	PART NUMBER	QTY	DESCRIPTION	REMARKS
1.	154-233	2	CONNECTOR (08S-080)	
2.	117-388	2	ABRASION SLEEVE (1.25" X 42")	
3.	309-204	1	BULKHEAD PLATE	
4.	515-718	2	HOSE (080FX90S-42"-3000)	
5.	154-396	2	BK CONNECTOR (080-08090BK)	
6.	117-324	2	ABRASION SLEEVE (1.25" X 48")	
7.	154-716	2	HOSE (080FX90-48"-3000)	
8.	154-307	2	CONNECTOR (16S-080)	
9.	149-895	-	HYD MOTOR	
	500-390		SEAL REPAIR KIT - REAR	
	500-391		SEAL REPAIR KIT - SHAFT	
	107-792		BOLT (5/16"X 1-5/8", DBL HEX)	
	165-900		KEY (7/16" SQ X 1.250")	
	105-917		CASTLE NUT (1-1/4-NF)	
10.	158-064	-	HYD CONTROL VALVE (4-SPOOL)	

NOT SHOWN:

FOOTNOTES:

NOTE:

REFER TO O-RING CHART (800-301) IN BACK OF THE BOOK FOR REPLACEMENT OF O-RINGS

# LEFT ANCHOR THRUST CYLINDER

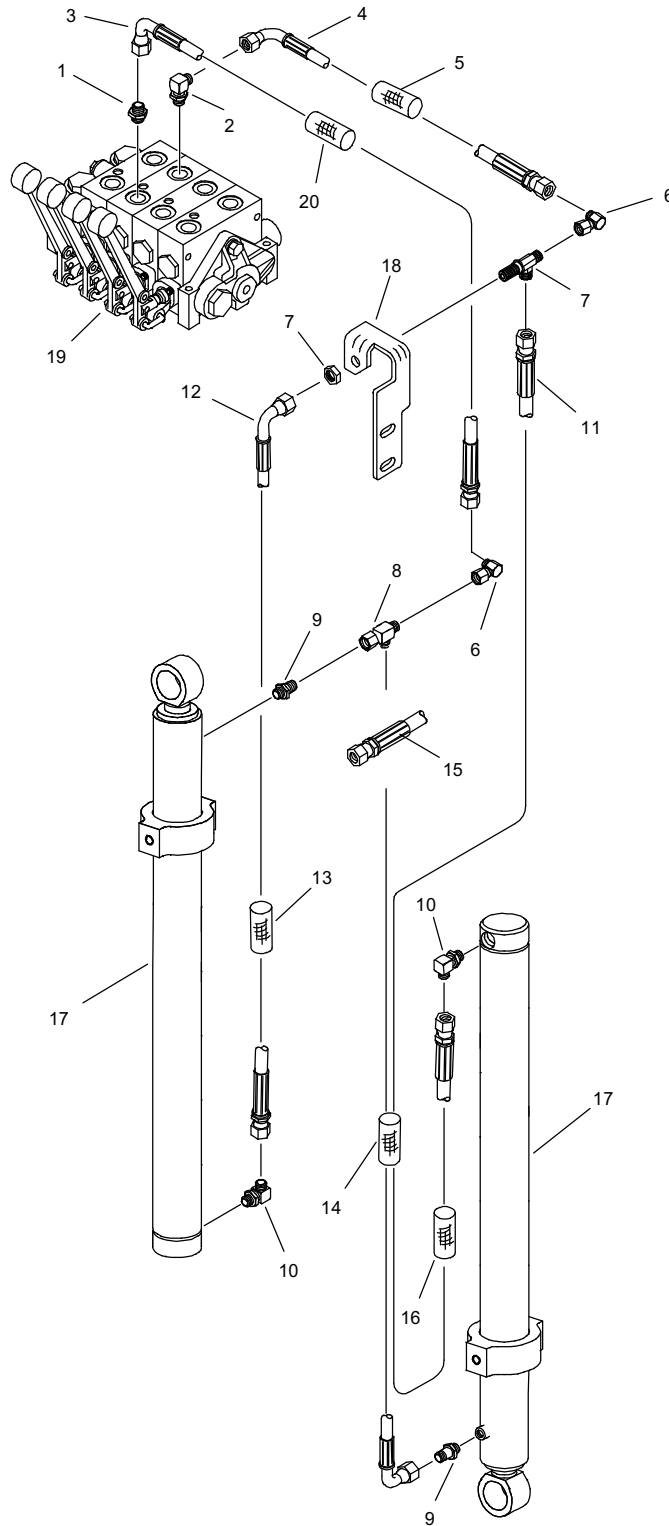

## LEFT ANCHOR THRUST CYLINDER

REF NO.	PART NUMBER	QTY	DESCRIPTION	REMARKS
1.	154-261	1	CONNECTOR (040-08S)	
2.	154-276	1	CONNECTOR (040-08S90)	
3.	515-713	1	HOSE (040FX90-38"-3000)	
4.	154-728	1	HOSE (040FX90-36"-3000)	
5.	117-718	1	ABRASION SLEEVE (1.00" X 36")	
6.	154-255	2	UNION (040-040FX90)	
7.	154-424	1	BK RUN TEE (040-040-040BK)	
8.	154-265	1	UNION RUN TEE (040FX-040-040)	
9.	154-403	2	CONNECTOR (04S-040, XL)	
10.	154-252	2	CONNECTOR (04S-04090)	
11.	515-054	1	HOSE (040FX-74"-3000)	
12.	515-683	1	HOSE (040FX90-28"-3000)	
13.	117-409	1	ABRASION SLEEVE (1.00" X 28")	
14.	117-657	1	ABRASION SLEEVE (1.59" X 54")	
15.	515-682	1	HOSE (040FX90-48"-3000)	
16.	117-676	1	ABRASION SLEEVE (1.00" X 30")	
17.	150-747	2	CYLINDER ASSEMBLY	
18.	309-206	1	BULKHEAD PLATE	
19.	158-064	-	HYD CONTROL VALVE	
20.	117-410	1	ABRASION SLEEVE (1.00" X 38")	

NOT SHOWN:

FOOTNOTES:

NOTE:

REFER TO O-RING CHART (800-301) IN BACK OF THE BOOK FOR REPLACEMENT OF O-RINGS.

# RIGHT ANCHOR THRUST CYLINDER

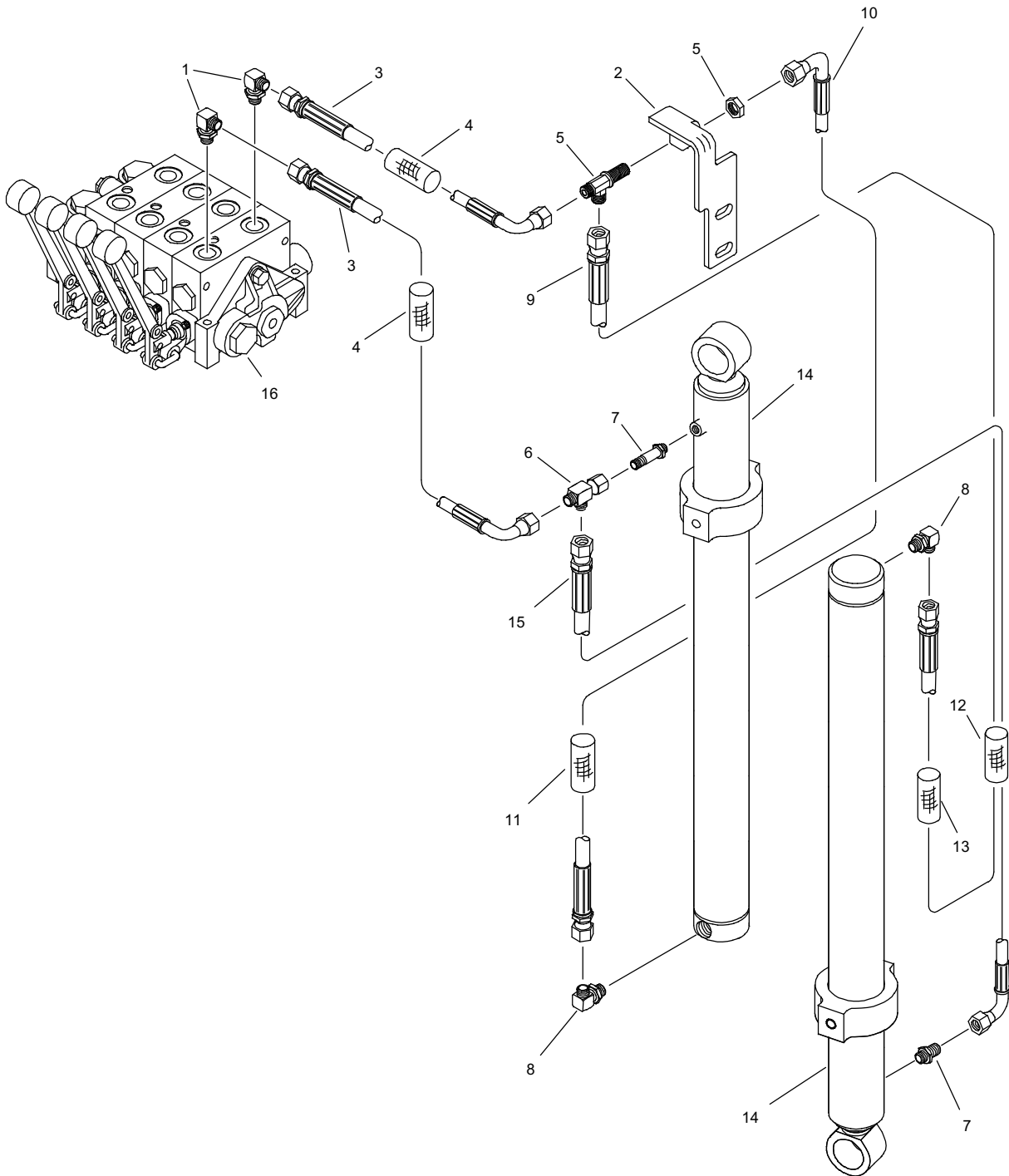

## RIGHT ANCHOR THRUST CYLINDER

REF NO.	PART NUMBER	QTY	DESCRIPTION	REMARKS
1.	154-276	2	CONNECTOR (040-08S90)	
2.	309-205	1	BULKHEAD PLATE	
3.	154-728	2	HOSE (040FX90-36"-3000)	
4.	117-718	2	ABRASION SLEEVE (1.00" X 36")	
5.	154-424	1	BK RUN TEE (040-040-040BK)	
6.	154-265	1	UNION RUN TEE (040FX-040-040)	
7.	154-403	2	CONNECTOR (04S-040, XL)	
8.	154-252	2	CONNECTOR (04S-04090)	
9.	515-054	1	HOSE (040FX-74"-3000)	
10.	515-683	1	HOSE (040FX90-28"-3000)	
11.	117-409	1	ABRASION SLEEVE (1.00" X 28")	
12.	117-657	1	ABRASION SLEEVE (1.59" X 54")	
13.	117-676	1	ABRASION SLEEVE (1.00" X 30")	
14.	150-747	2	CYLINDER ASSEMBLY	
15.	515-682	1	HOSE (040FX90M-48"-3000)	
16.	158-064	-	HYD CONTROL VALVE	

NOT SHOWN:

FOOTNOTES:

NOTE:

REFER TO O-RING CHART (800-301) IN BACK OF THE BOOK FOR REPLACEMENT OF O-RINGS.

# HYDRAULIC CYLINDER

2.0" X 1.25" X 24.0"

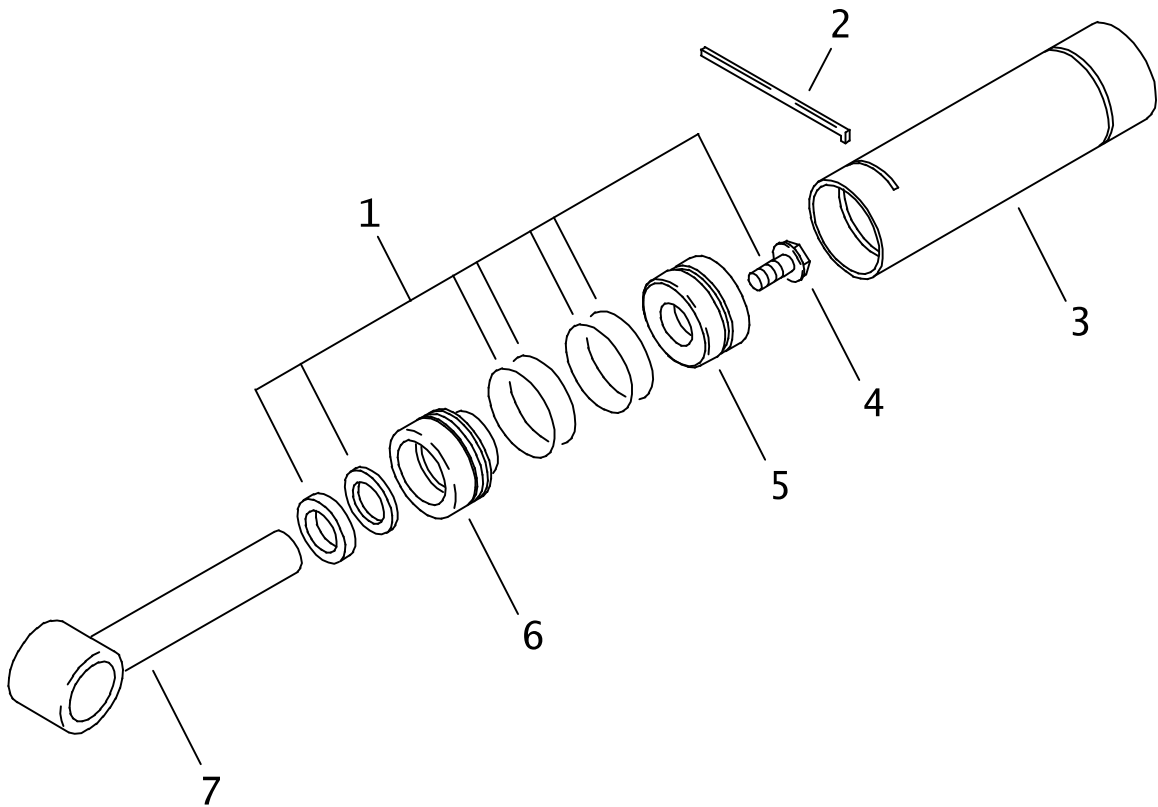

## HYDRAULIC CYLINDER

### 2.0" X 1.25" X 24.0"

REF NO.	PART NUMBER	QTY	DESCRIPTION	REMARKS
	150-747		CYL (2" X 1.25" X 24")	INCLUDE REF NO.'S 1 THRU 7
1.	190-169	1	SEAL REPAIR KIT (2.0" X 1.25")	INCLUDES REF NO.'S 4 & 5
2.	150-778	1	LOCK RING (2")	
3.	151-170	1	CYLINDER BARREL	
4.	106-097	1	FLG BOLT (5/8-NC X 1-3/4", GD8)	SEE FOOTNOTE 1
5.	150-771	1	CYLINDER PISTON (2.0" X 1.25")	INCLUDES MOLDED-ON WEAR RING
6.	150-770	1	CYLINDER HEAD (2.0" X 1.25")	
7.	150-679	1	CYLINDER ROD (1.25")	

#### NOT SHOWN:

259-100	U-SEAL INSTALLER (1"-1.499")
259-236	WIPER INSTALLER (1.250")
259-239	WIPER/SEAL INSTALLER (2")
259-241	PISTON INSTALLER (2")
259-188	CYL HEAD SPANNER - TWO PIN

#### FOOTNOTES

1. APPLY LOCTITE 271 OR 277. TORQUE TO 180-200 FT-LBS (245-270 N.M.)

#### NOTE:

D

806-687





# **FLUID SYSTEMS**

## MUD PUMP &amp; ANTIFREEZE TANK

BEGINS WITH S/N 2X0001

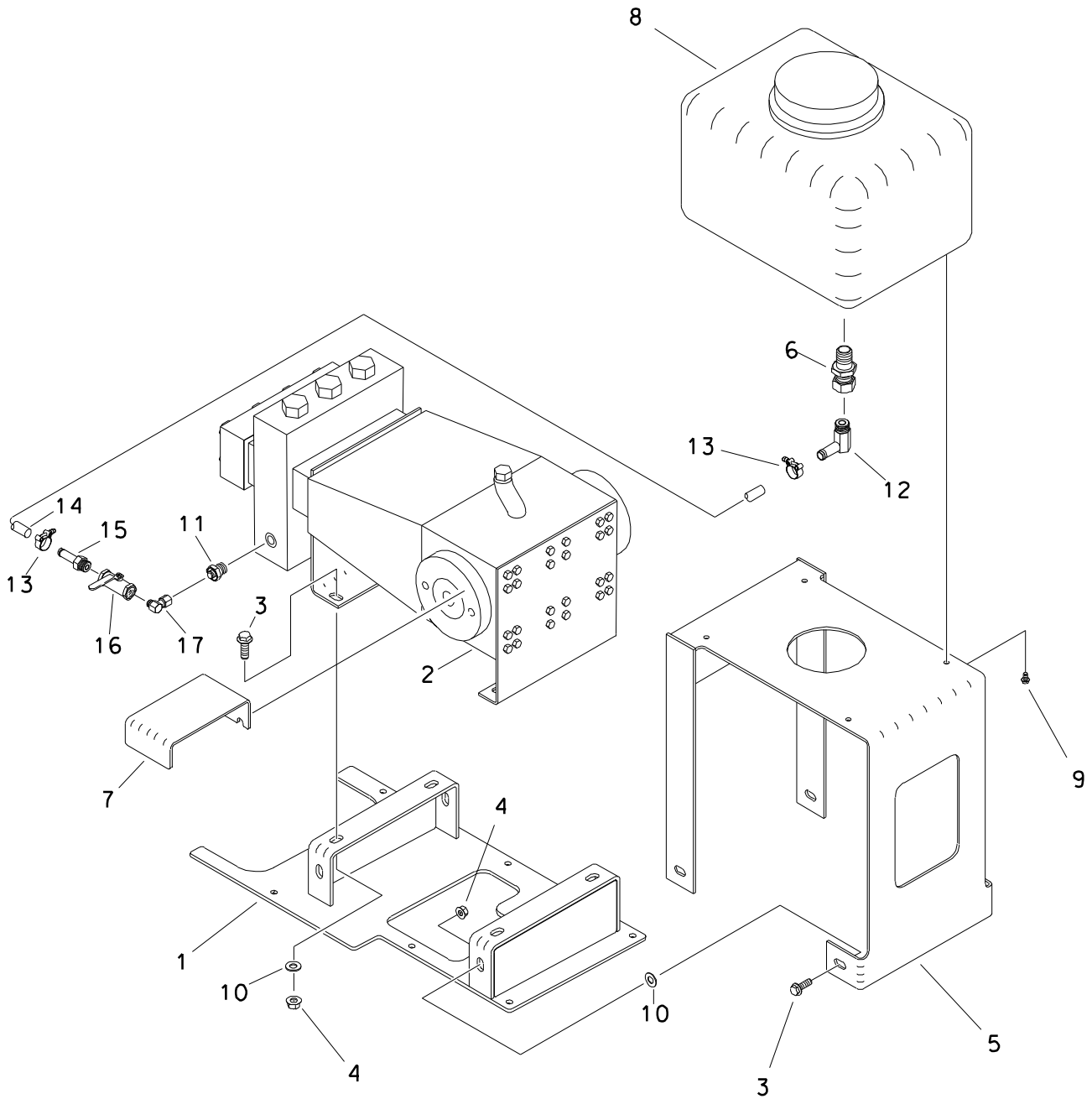

## MUD PUMP &amp; ANTIFREEZE TANK

BEGINS WITH S/N 2X0001

REF NO.	PART NUMBER	QTY	DESCRIPTION	REMARKS
	190-838		ANTIFREEZE KIT	INCL REF NO.'S 5, 8, & 12 THRU 16, & 17
1.	343-563	-	COVER	
2.	153-544	-	MUD PUMP	
3.	106-383	8	FLG LK SCREW (M10-1.75 X 30mm)	
4.	105-894	8	LOCKNUT (M10-1.5, PRV TRQ, 10.9)	
5.	343-241	1	TANK SUPPORT	
6.	514-400	1	BK CONN (16NF-16NFBK, NYL)	
	157-490	1	BK CONNECTOR (16NF, POLY)	SEE FOOTNOTE 1, BEGINS WITH S/N 2X0001
7.	309-751	1	PLATE, COVER	
8.	364-515	1	WATER TANK (8 GAL)	
	110-707		TANK CAP (96NF)	
	190-053		POLY-PATCH TANK REPAIR KIT	
9.	105-836	4	FLG LOCK BOLT (1/4-NC X 1/2")	
10.	106-397	8	WASHER (M12, HARDENED)	
11.	514-438	1	REDUCER (32N-16N)	LOCTITE 567
12.	155-137	1	S/O COUPLER (16N-16H90)	LOCTITE 567
13.	111-027	2	T-BOLT CLAMP (1.25"-1.50")	
14.	116-460	AR	BULK HOSE (1", SOLD PER 1')	USE 1 @ 16"
15.	155-136	1	S/O COUPLER (16N-16H)	LOCTITE 567
16.	514-318	1	SHUT-OFF (16NF-16NF)	
17.	155-113	1	UNION (16N-16NFX90)	LOCTITE 567

## FOOTNOTES

1. HOLES MAY REQUIRE MODIFICATION FOR NEW FITTINGS.

# MUD PRESSURE HYDRAULICS

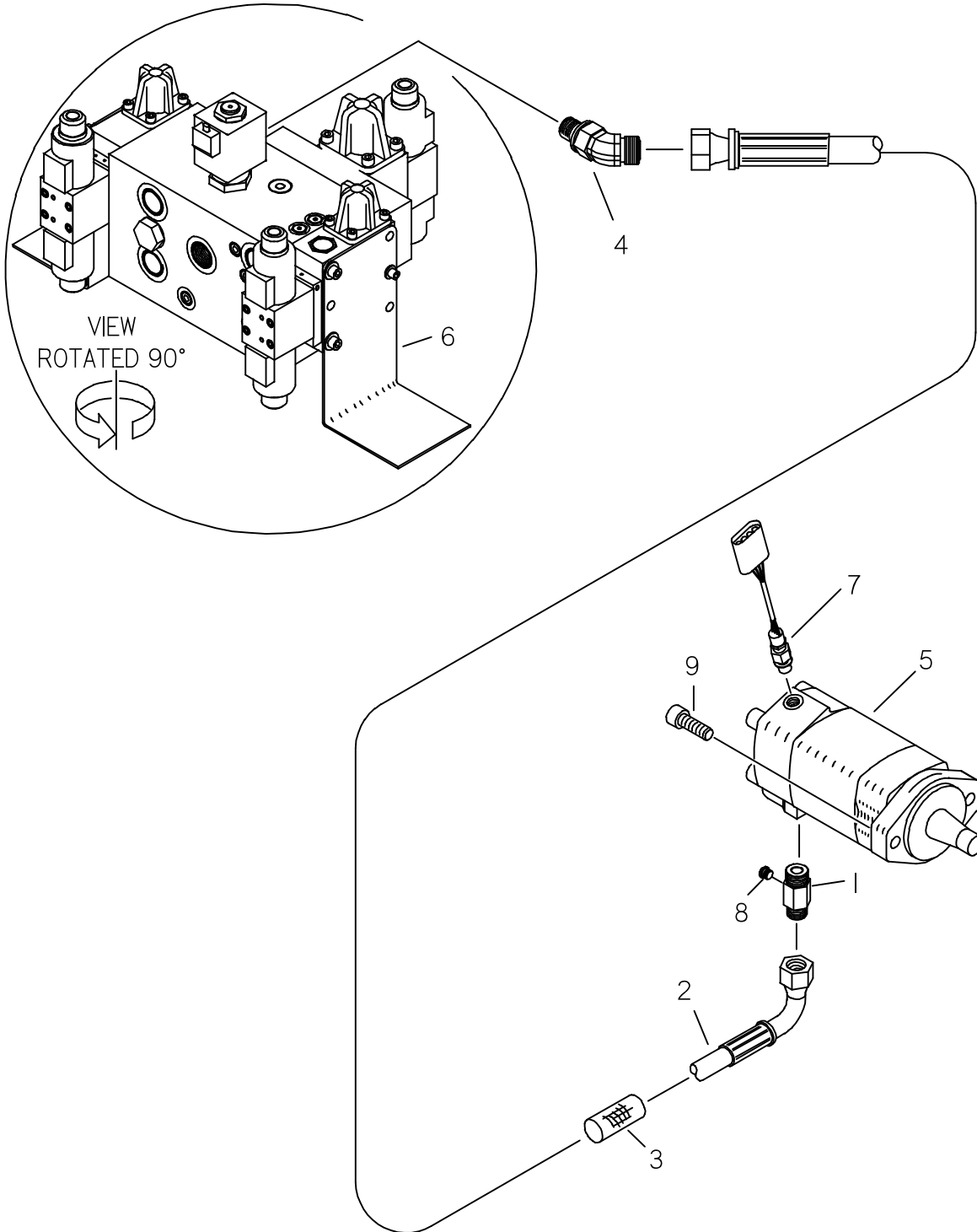

## MUD PRESSURE HYDRAULICS

REF NO.	PART NUMBER	QTY	DESCRIPTION	REMARKS
1.	I53-263	1	SPECIAL TEE (I0S-I00-04SF)	
2.	I55-466	1	HOSE (I00FX90-74"-2750)	
3.	I15-963	1	ABRASION SLEEVE (I.59" X 75")	
4.	I54-470	1	CONNECTOR (I00-I2S45)	
5.	I58-936	1	HYD MOTOR	
	500-658		SEAL REPAIR KIT	
6.	I50-225I	-	HYDRAULIC CONTROL VALVE	
7.	214-010	-	SPEED SENSOR	
8.	I54-383	1	PLUG (04S)	
9.	I06-204	2	BOLT (I/2-NC X I-I/2", SOC)	LOCTITE 242, TORQUE TO 100 FT-LBS.

NOT SHOWN:

FOOTNOTES:

**NOTE:**

REFER TO O-RING CHART (800-30I) IN BACK OF THE BOOK FOR REPLACEMENT OF O-RINGS.

# MUD PUMP HYDRAULICS

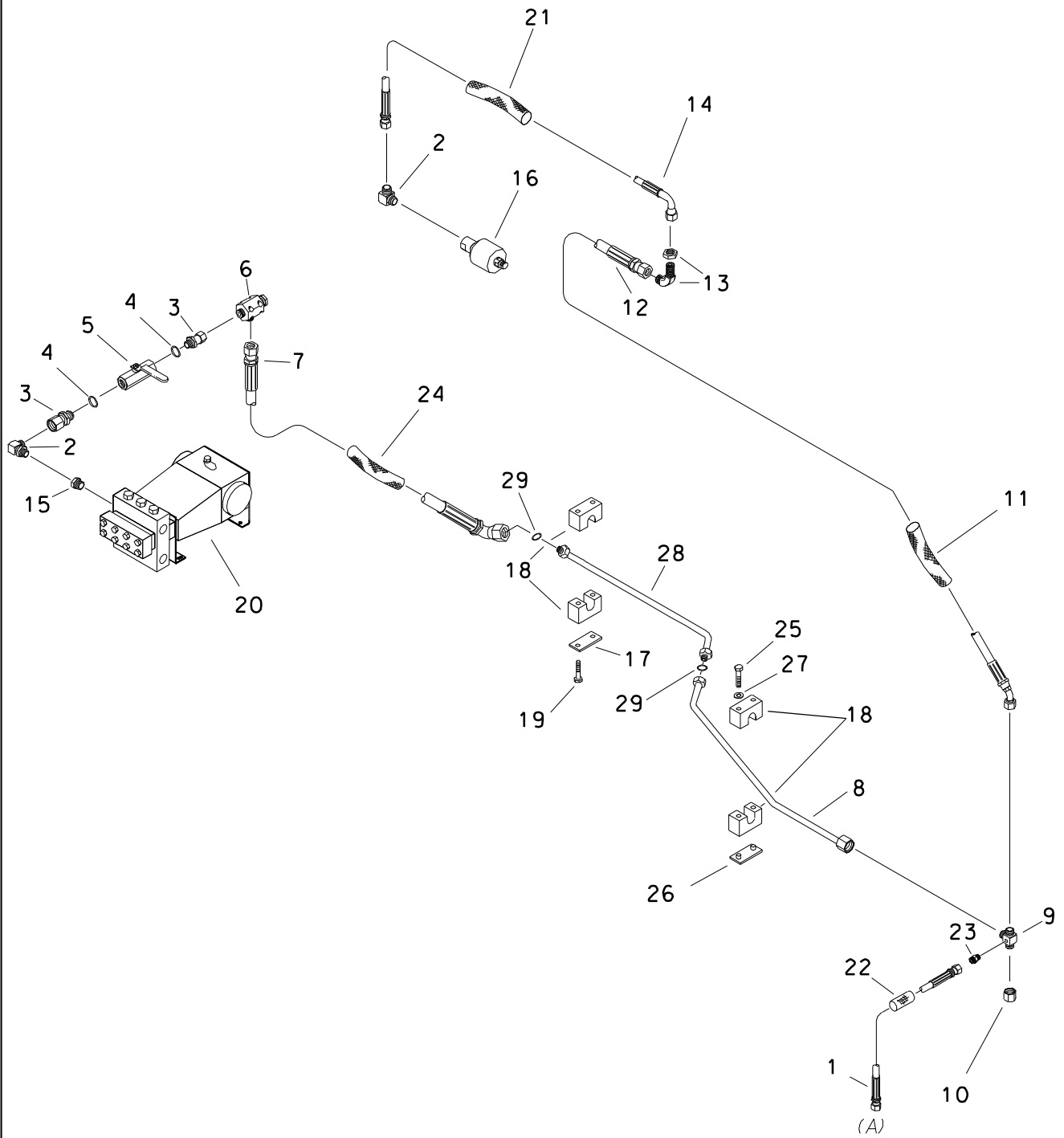

## MUD PUMP HYDRAULICS

REF NO.	PART NUMBER	QTY	DESCRIPTION	REMARKS
1.	515-013	1	HOSE (040FX-42"-3000)	
2.	510-011	2	CONNECTOR (16N-16090)	LOCTITE 567
3.	510-014	2	UNION (16J-160FX)	
4.	155-748	2	O-RING (916 D90)	
5.	120-074	1	SHUT-OFF VALVE (16S-16S)	
6.	159-451	1	CHECK VALVE	
7.	149-514	1	HOSE (160FX45S-50"-3000)	
8.	149-483	1	HYD LINE (160FX-160FX)	
9.	149-637	1	TEE (16J-160-160, SPECIAL)	
10.	510-016	1	CAP (16JF)	
11.	117-292	1	ABRASION SLEEVE (2.07" X 70")	
12.	149-603	1	HOSE (160FX45S-160"-3000)	
13.	154-419	1	BK CONNECTOR (160-16090BK)	
14.	153-293	1	HOSE (160FX90M-38"-3000)	
15.	115-261	1	REDUCER (24N-16NF)	LOCTITE 567
16.	159-382	1	WATER SWIVEL (16N-16NF)	SEE FOOTNOTE 1
	190-905	-	SWIVEL REPAIR KIT	
17.	322-289	1	BACKUP (BOLT-ON)	
18.	110-573	2	BOLT-ON CLAMP (1", SOLD PER SET)	
19.	105-818	2	BOLT (1/4-NC X 1-1/2")	
20.	153-544	1	MUD PUMP	
21.	117-455	1	ABRASION SLEEVE (2.07" X 38")	
22.	117-387	1	ABRASION SLEEVE (1.00" X 42")	
23.	154-339	1	CONNECTOR (04N-040)	
24.	117-454	1	ABRASION SLEEVE (2.07" X 50")	
25.	105-106	2	BOLT (1/4-NC X 2")	
26.	322-290	1	MOUNT (WELD-ON)	
27.	105-284	2	WASHER (3/16")	
28.	149-599	1	HYDRAULIC LINE (-16)	
29.	155-714	2	O-RING (021 D90)	

## FOOTNOTES

1. INSTALL USING NICKEL THREAD SEALING TAPE (117-555) ON MALE THREADS.

(A) CONNECTS TO LOWER BULKHEAD ON OPERATOR STATION

## NOTE

REFER TO O-RING CHART (800-301) IN BACK OF THE BOOK FOR REPLACEMENT OF O-RINGS.

**MUD PUMP**  
46 GPM  
ENDS WITH S/N 2V1841

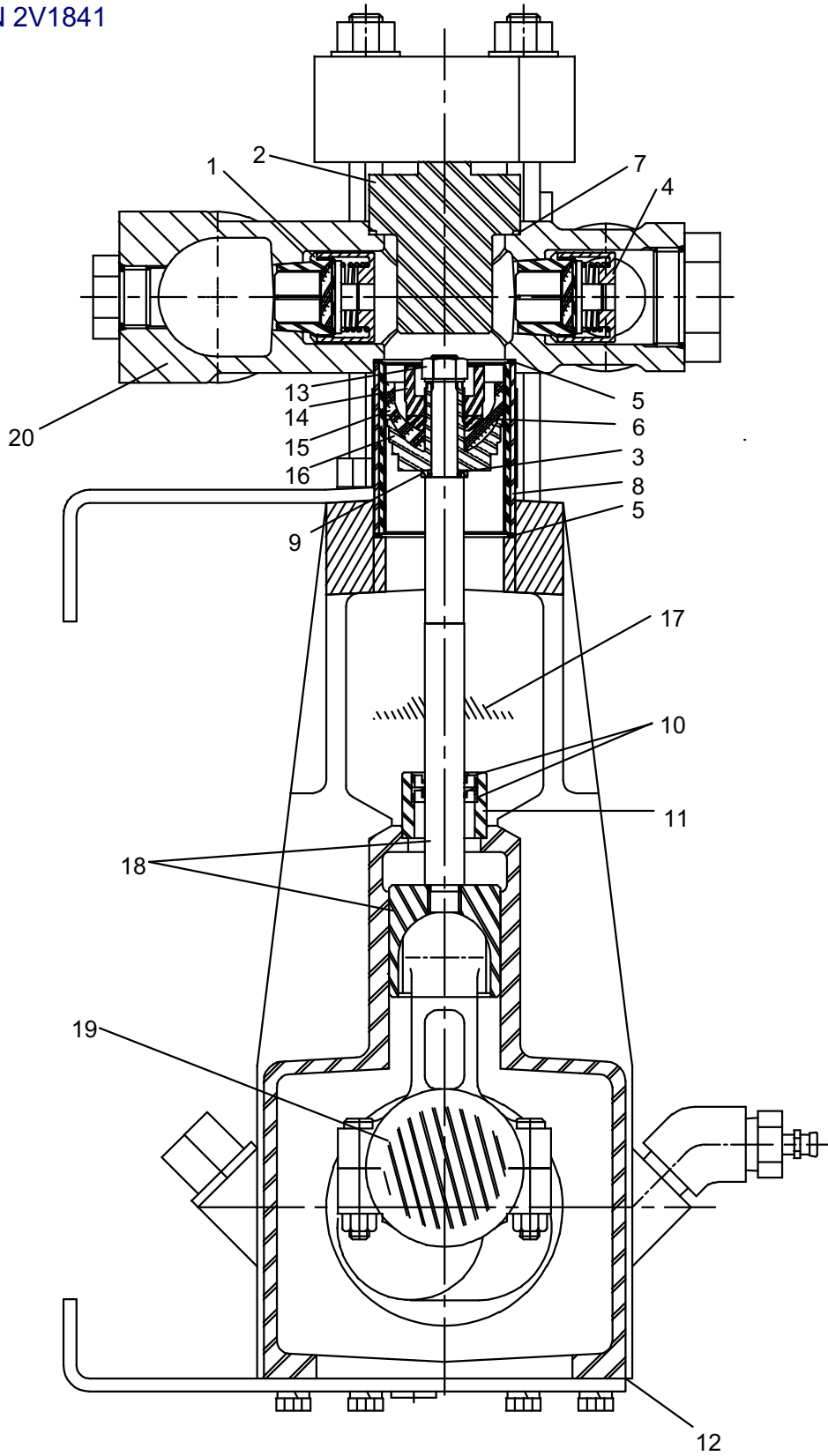



## MUD PUMP 46 GPM ENDS WITH S/N 2V1841

REF NO.	PART NUMBER	QTY	DESCRIPTION	REMARKS
	158-016	-	MUD PUMP (17.9 CU/IN, 46 GPM)	
	190-801		SEAL REPAIR KIT	INCLUDES 3,5,7,15.
	191-094		PACKING REPAIR KIT	
	197-059		REBUILT MUD PUMP	
	190-802		VALVE REPAIR KIT	INCLUDES 1.4
1.	499-110	3	VALVE - SUCTION AR	
2.	499-118	3	CYLINDER COVER	
3.	499-116	3	O-RING (014 D70)	
4.	499-111	3	VALVE - DISCHARGE AR	
5.	165-730	3	CYLINDER GASKET	
6.	499-119	3	WASHER	
7.	499-115	3	O-RING (146 D70)	
8.	499-112	3	CERAMIC CYLINDER	
9.	499-113	3	SEAL HOLDER	
10.	499-125	6	EXTERNAL SEAL	
11.	499-126	3	SEAL HOLDER	
12.	499-123	1	BASE GASKET	
13.	107-734	3	LOCKNUT (1/2-NC, BRASS)	
14.	499-039	3	PLUNGER NUT	
15.	499-121	3	PISTON CUP (HSN)	SEE FOOTNOTE 1. OBSOLETE
16.	499-117	3	PISTON HOLDER	
17.	153-438	3	WIPER SEAL	
18.	499-392	3	CROSSHEAD ROD ASSEMBLY	
19.	499-393	3	ROD BEARING (PAIR)	
20.	499-569	1	FLUID CYLINDER (L06)	

### NOT SHOWN:

499-122	2	BEARING HOUSING GASKET
499-124	1	GREASE SEAL
259-352	-	FMC PISTON/PACKING TOOL
259-470	-	FMC VALVE TOOL
499-394	1	SIGHT GAGE (FMC)

### FOOTNOTES:

1. INDIVIDUAL PISTON CUPS NO LONGER AVAILABLE. ORDER SEAL REPAIR KIT 190-801.

### NOTE:

**MUD PUMP**  
46 GPM BEGINS WITH S/N 2V1841

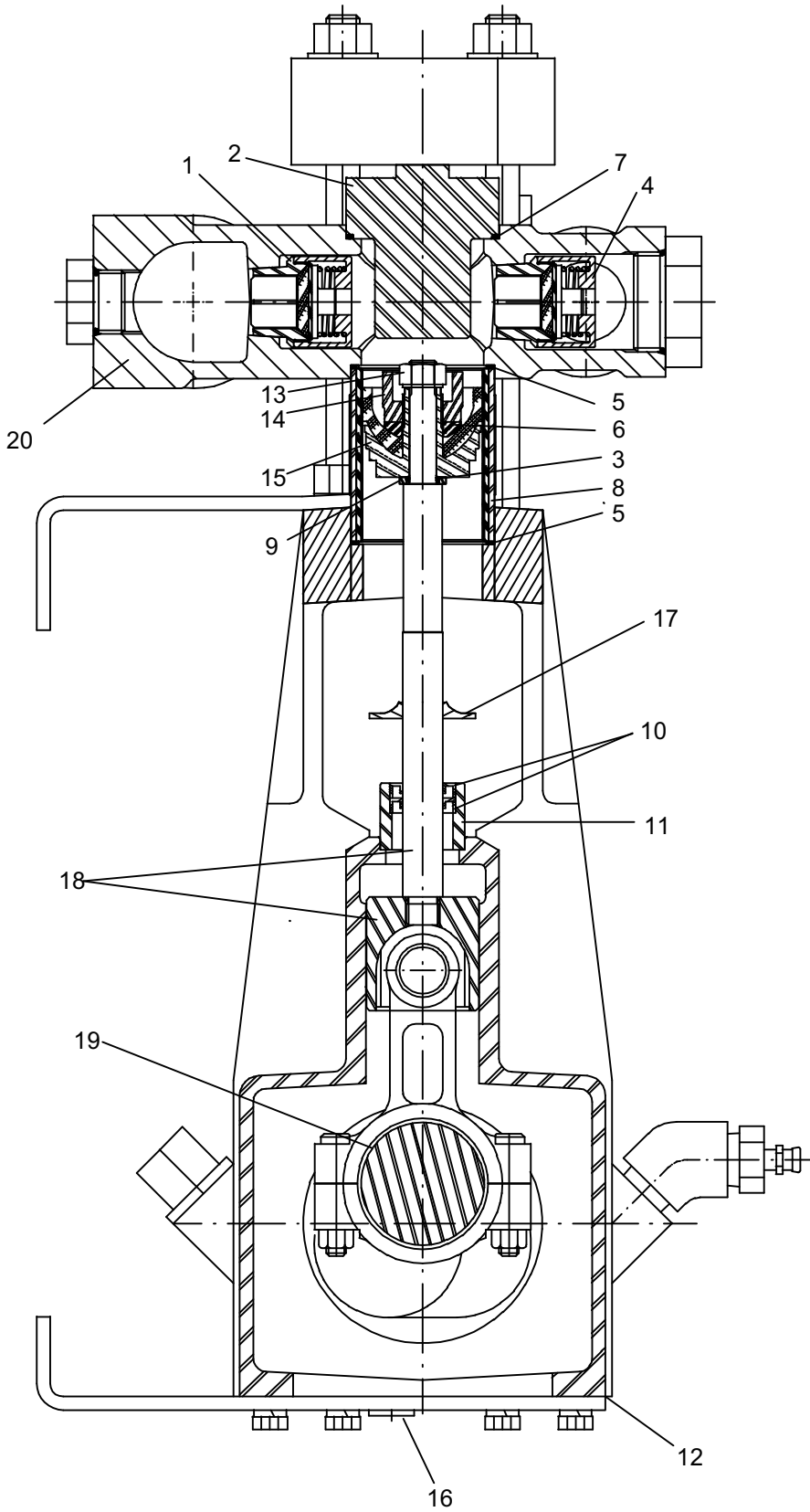

## MUD PUMP

### 46 GPM BEGINS WITH S/N 2V1841

REF NO.	PART NUMBER	QTY	DESCRIPTION	REMARKS
	153-544	-	MUD PUMP (17.9 CU/IN, 46 GPM)	
	191-094		PACKING REPAIR KIT	INCLUDES 3,5,7 & PISTON CUPS
	197-083		REBUILT MUD PUMP	
	190-802		VALVE REPAIR KIT	INCLUDES 1,4
1.	499-110	3	VALVE - SUCTION AR	
2.	499-118	3	CYLINDER COVER	
3.	499-116	3	O-RING (014 D70)	
4.	499-111	3	VALVE - DISCHARGE AR	
5.	165-730	3	CYLINDER GASKET	
6.	499-119	3	WASHER	
7.	499-115	3	O-RING (146 D70)	
8.	499-302	3	CERAMIC CYLINDER	
9.	499-113	3	SEAL HOLDER	
10.	499-125	6	EXTERNAL SEAL	
11.	499-126	3	SEAL HOLDER	
12.	499-123	1	BASE GASKET	
13.	499-114	3	NUT (HEX, SPECIAL, BRASS)	
14.	499-039	3	PLUNGER NUT	
15.	310-962	3	PISTON HOLDER	
16.	499-394	1	SIGHT GAGE	
17.	153-438	1	WIPER SEAL	
18.	499-392	1	CROSSHEAD ROD ASSEMBLY	
19.	499-393	1	ROD BEARING (PAIR)	
20.	499-569	1	FLUID CYLINDER (L06)	

NOT SHOWN:

499-122	2	BEARING HOUSING GASKET
499-124	1	GREASE SEAL
259-352	-	FMC PISTON/PACKING TOOL
259-470	-	FMC VALVE TOOL

FOOTNOTES:

NOTE:

INTERNAL WATER SWIVEL  
JT2720 MACH 1 ALL TERRAIN ONLY  
ENDS WITH S/N

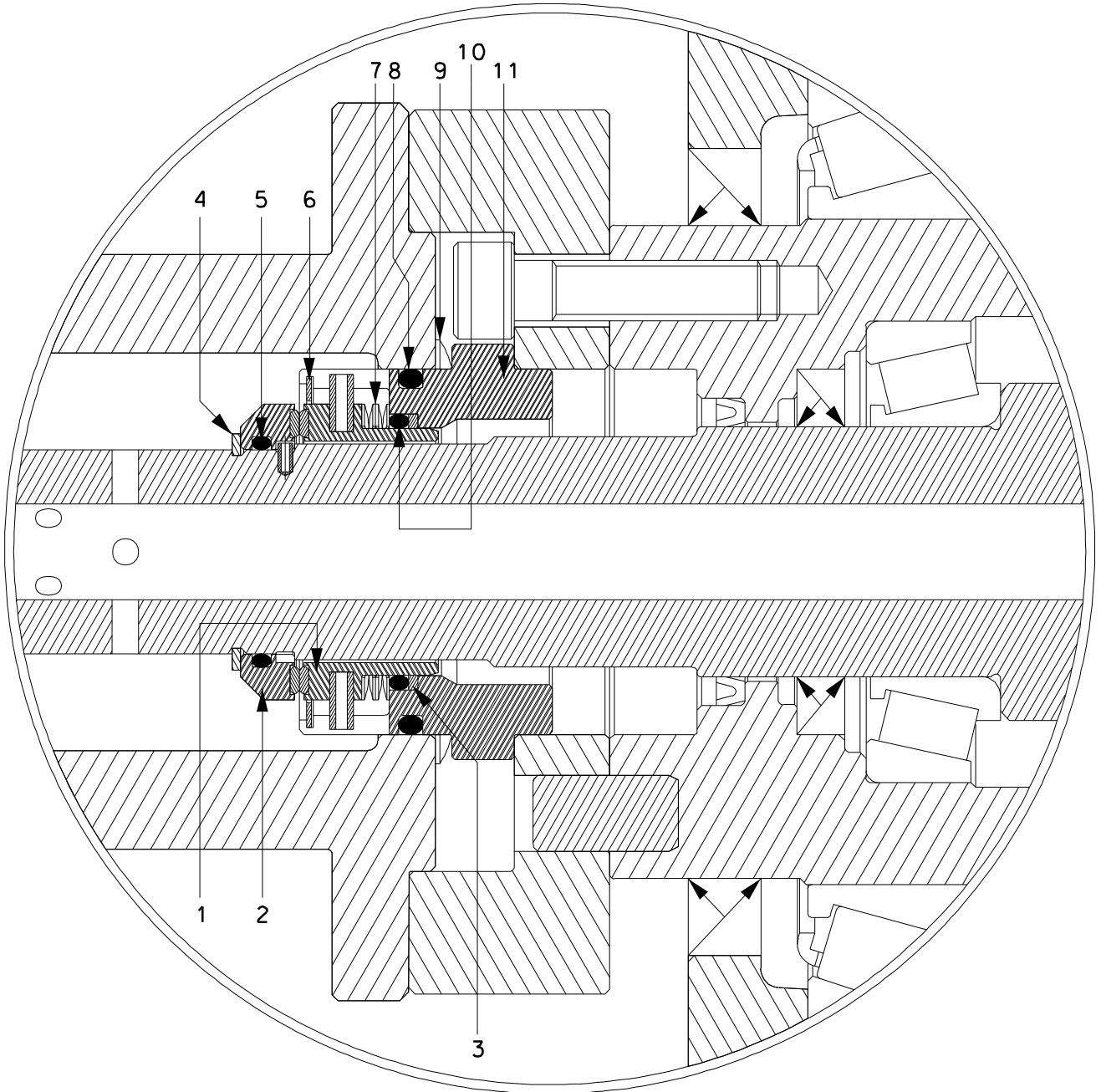

INTERNAL WATER SWIVEL  
 JT2720 MACH 1 ALL TERRAIN ONLY  
 ENDS WITH S/N

REF NO.	PART NUMBER	QTY	DESCRIPTION	REMARKS
	191-129	-	SEAL REPAIR KIT (153-191)	INCLUDES REF. NO. 3, 4, 5, 8, AND 10
1.			FLOATING SEAL	
2.			SEAL	
3.			BACKUP WASHER	
4.			SNAP RING	
5.			METRIC O-RING 33.5MM X 2.5MM	
6.			SPIROLOX	
7.			STACKED WAVE SPRING	
8.			O-RING #227	
9.			PRELOAD SPRING	SEE FOOTNOTE 1
10.			O-RING #130	
11.			HOUSING	

FOOTNOTES

1. DURING ASSEMBLY, ENSURE THAT THE PRELOAD SPRING IS IN THIS POSITION

## MUD PUMP INLET &amp; WASH WAND CONNECTION

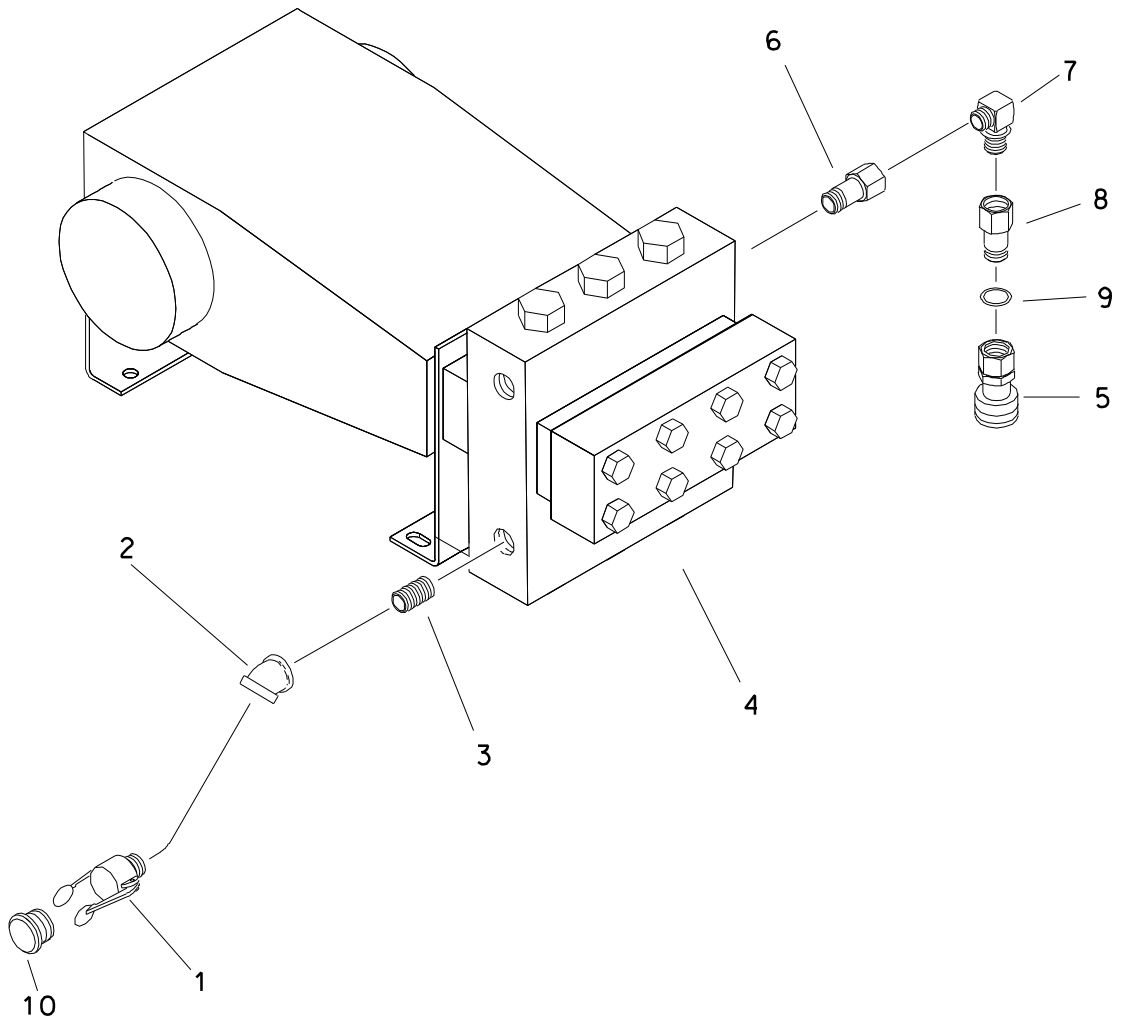

# MUD PUMP INLET & WASH WAND CONNECTION

REF NO.	PART NUMBER	QTY	DESCRIPTION	REMARKS
1.	159-485	1	FHC ADAPTER (32-32N)	LOCTITE 567
2.	115-297	1	CONNECTOR (32NF-32NF45)	
3.	115-295	1	NIPPLE (32N-3")	LOCTITE 567
4.	153-544	-	MUD PUMP	
5.	159-088	1	QDC BODY (08-08SF)	
	190-186	1	SEAL REPAIR KIT	
6.	115-271	1	REDUCER (24N-12NF)	LOCTITE 567
7.	154-490	1	CONNECTOR (12N-08090)	
8.	156-732	1	CONNECTOR (08J-080)	
9.	155-706	1	O-RING (908 D90)	
10.	149-120	1	DUST PLUG (32 FHC)	

FOOTNOTES

NOTE  
REFER TO O-RING CHART (800-301) IN BACK OF THE BOOK FOR REPLACEMENT OF O-RINGS.

# WASH WAND

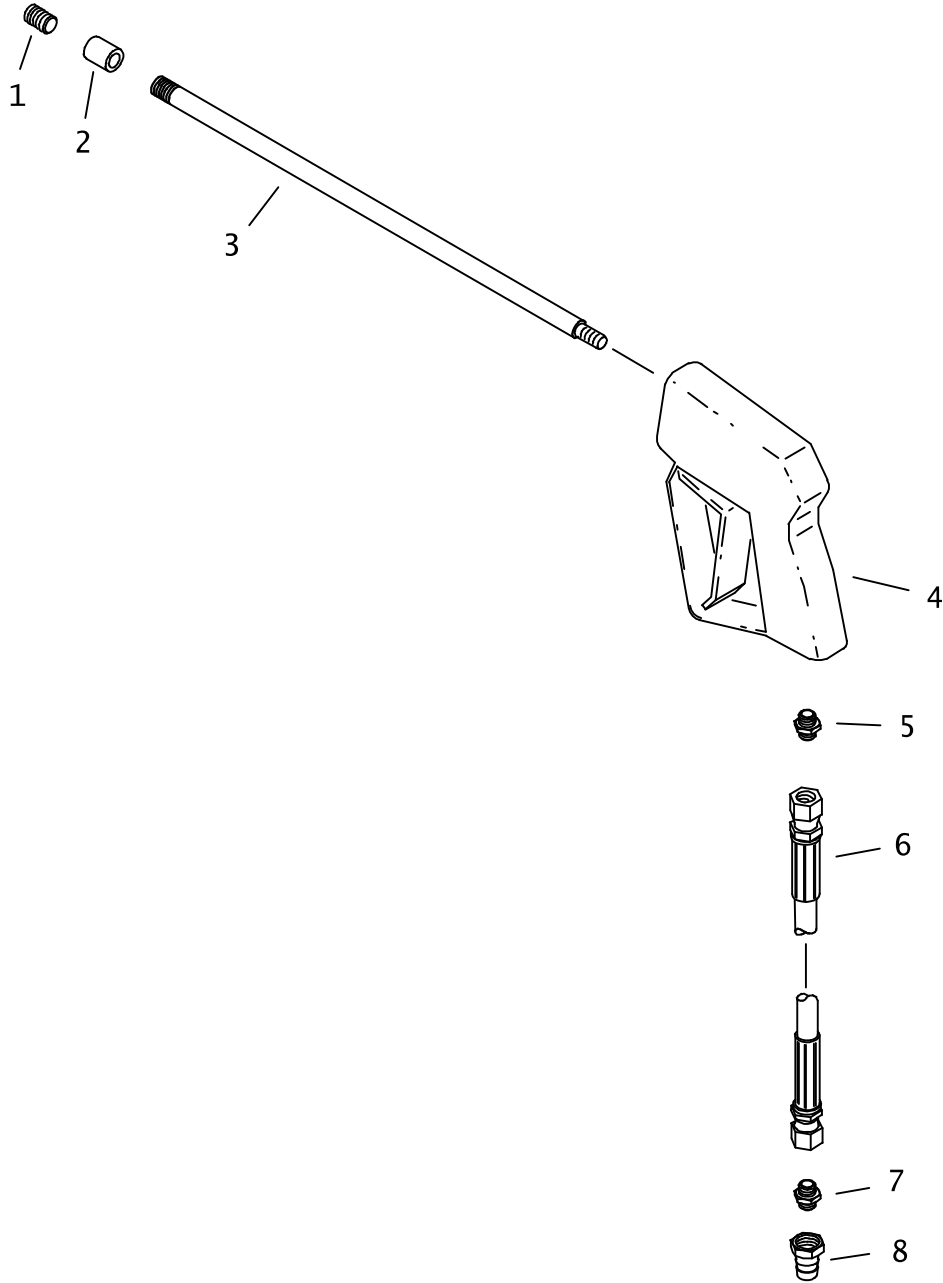



## WASH WAND

REF NO.	PART NUMBER	QTY	DESCRIPTION	REMARKS
	259-374		WATER SPRAY GUN (PARTS ASS'Y)	INCL REF NO.'S 1 THRU 8
1.	155-242	1	NOZZLE (04N, ORF. 047", TC)	
2.	115-170	1	COLLAR (04NF)	
3.	259-353	1	WASH WAND (04N-36")	
4.	259-197	1	SPRAY GUN	
	190-179	1	SEAL REPAIR KIT	
5.	514-141	1	CONNECTOR (06N-080)	
6.	154-804	1	HOSE (080FX-290"-3000)	
7.	154-233	1	CONNECTOR (08S-080)	
8.	159-089	1	QDC ADAPTER (08-08SF)	
	190-186	1	SEAL REPAIR KIT	

NOT SHOWN:

FOOTNOTES:

NOTE:

REFER TO O-RING CHART (800-301) IN BACK OF THE BOOK FOR REPLACEMENT OF O-RINGS.



# **PIPE LOADER SYSTEMS**

## GREASE PUMP MOUNTING

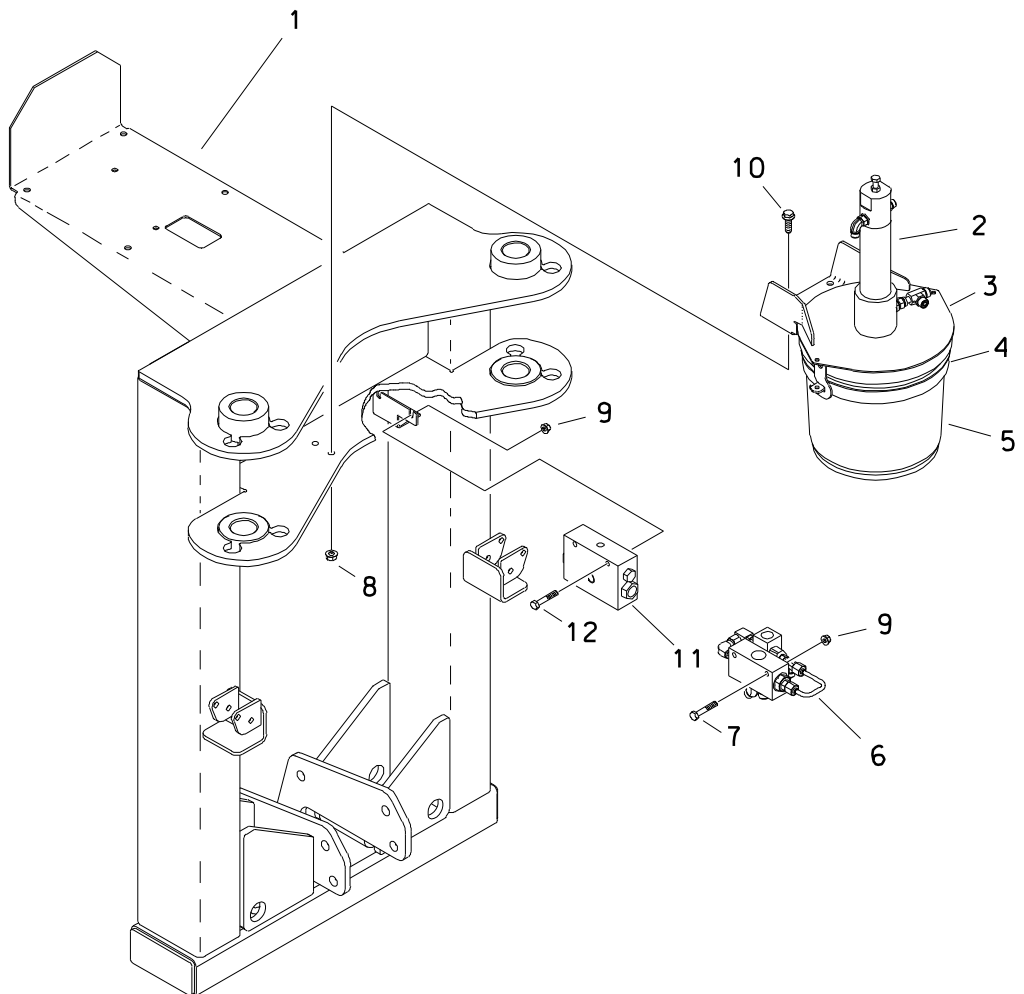

# GREASE PUMP MOUNTING

REF NO.	PART NUMBER	QTY	DESCRIPTION	REMARKS
1.	306-428	-	PIVOT FRAME	
2.	350-398	-	GREASE PUMP	
3.	350-400	-	COVER	
4.	350-399	-	BASE	
5.	259-858	-	TOOL JNT LUBE, STD SPRY 2 GAL	
	256-031	-	TOOL JNT LUBE, SUMR SPRY 2 GAL	
6.	N/A	-	VALVE SUB-ASS'Y	ENDS WITH S/N 2V0732
7.	106-329	-	SCREW (M8-1.25 X 50MM)	ENDS WITH S/N 2V0732
8.	106-387	4	FLG LOCKNUT (M10-1.50)	
9.	106-386	-	FLG LOCKNUT (M8-1.25)	
10.	106-383	4	FLG LK SCREW (M10-1.50 X 30MM)	
11.	310-591	1	VALVE ASS'Y	BEGINS WITH S/N 2V0733
12.	106-570	2	SCREW (M8-1.25 X 60MM)	BEGINS WITH S/N 2V0733

FOOTNOTES

# GREASER HYDRAULICS

ENDS WITH S/N

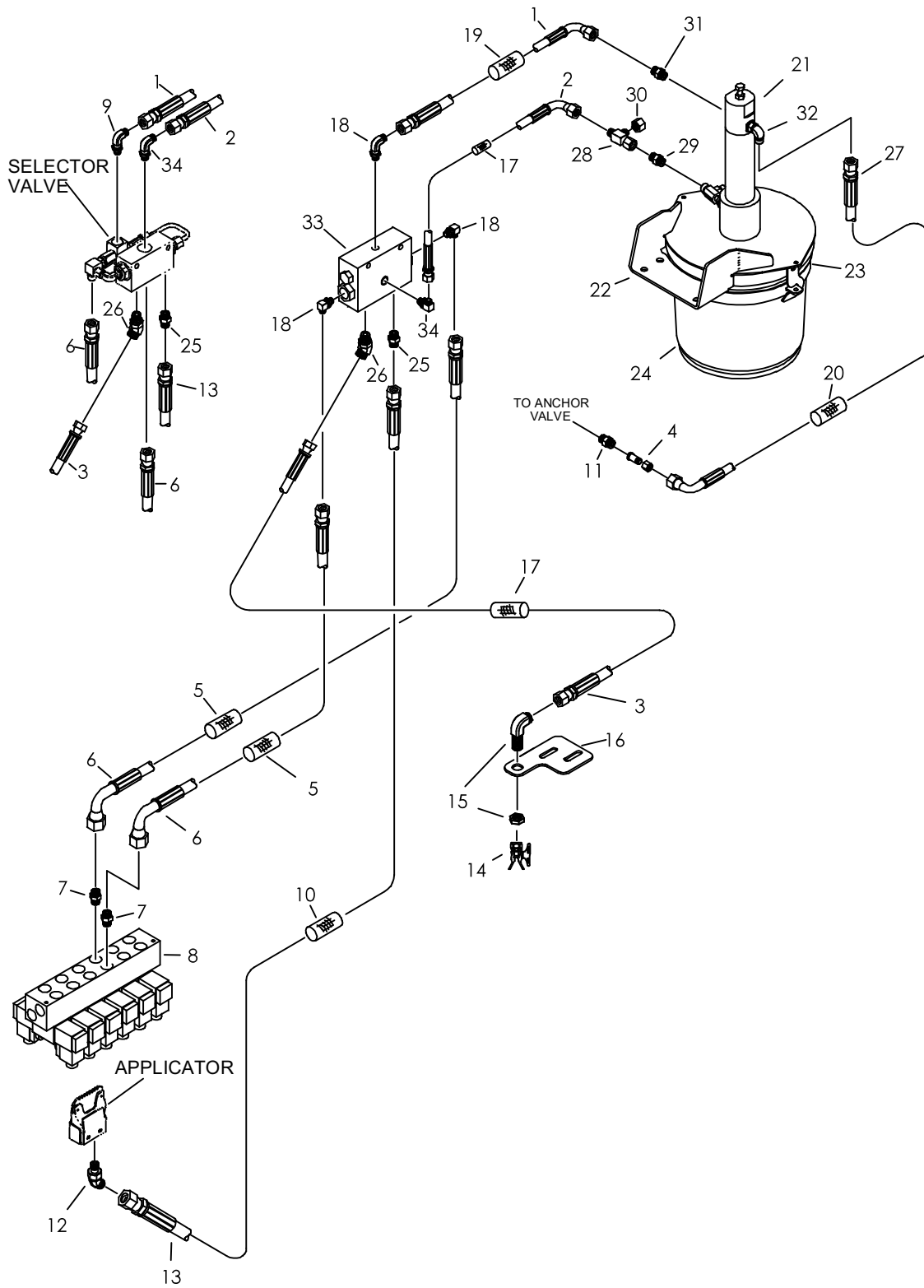

## GREASER HYDRAULICS ENDS WITH S/N

REF NO.	PART NUMBER	QTY	DESCRIPTION	REMARKS
1.	515-744	1	HOSE (040FX90S-28"-3000)	
2.	153-320	1	HOSE (060FX90L-17"-3000)	
3.	154-731	1	HOSE (060FX-17"-3000)	
4.	154-373	-	REDUCER (040-060F)	
5.	117-421	2	ABRASION SLEEVE (1.00" X 122")	
6.	153-318	2	HOSE (040FX90L-122"-3000)	
7.	154-278	2	CONNECTOR (04S-040)	
8.	153-095	1	HYD VALVE	
9.	154-226	1	CONNECTOR (040-06S90)	
10.	117-420	1	ABRASION SLEEVE (1.00" X 182")	
11.	159-381	-	CHECK VALVE (06S-060)	
12.	514-414	1	CONNECTOR (04S-06045)	
13.	153-319	1	HOSE (060FX-182"-3000)	
14.	149-399	1	SPRAY NOZZLE (65^)	USED ON JT27M1
	369-987	1	SPRAY NOZZLE	USED ON AT27M1
	400-137	1	SPRAY NOZZLE HANDLE KIT	
	153-096	1	CAP GASKET, NYLON	
15.	154-229	1	BK CONNECTOR (060-06090BK)	
16.	305-951	-	BRACKET, SPRAY	
17.	117-194	2	ABRASION SLEEVE (1.00 X 16")	
18.	154-252	3	CONNECTOR (04S-04090)	
19.	117-409	1	ABRASION SLEEVE (1.00" X 28")	
20.	117-280	1	ABRASION SLEEVE (1.00" X 25")	
21.	350-398	-	GREASE PUMP PARTS ASS'Y	
22.	350-400	-	COVER	
23.	350-399	-	BASE	
24.	259-858	-	TOOL JNT LUBE, STD SPRY 2 GAL	
	256-031	-	TOOL JNT LUBE, SUMR SPRY 2 GAL	
25.	514-165	1	CONNECTOR (06S-060, ORF .078")	
26.	154-224	1	CONNECTOR (06S-06045)	
27.	149-827	1	HOSE (040FX90S-24"-3000)	
28.	154-344	1	UN RUN TEE (060FX-060-060)	
29.	154-221	1	CONNECTOR (06S-060)	
30.	154-326	1	CAP (060F)	
31.	154-278	1	CONNECTOR (04S-040)	
32.	154-401	1	CONNECTOR (04S-04090, ORF)	
33.	310-591	1	VALVE ASS'Y	BEGINS WITH S/N
34.	154-342	1	CONNECTOR (06S-06090)	

NOT SHOWN:

FOOTNOTES:

NOTE

NOTE:

REFER TO O-RING CHART (800-301) ON BACK OF THE BOOK FOR REPLACEMENT OF O-RINGS.

## SELECTOR VALVE

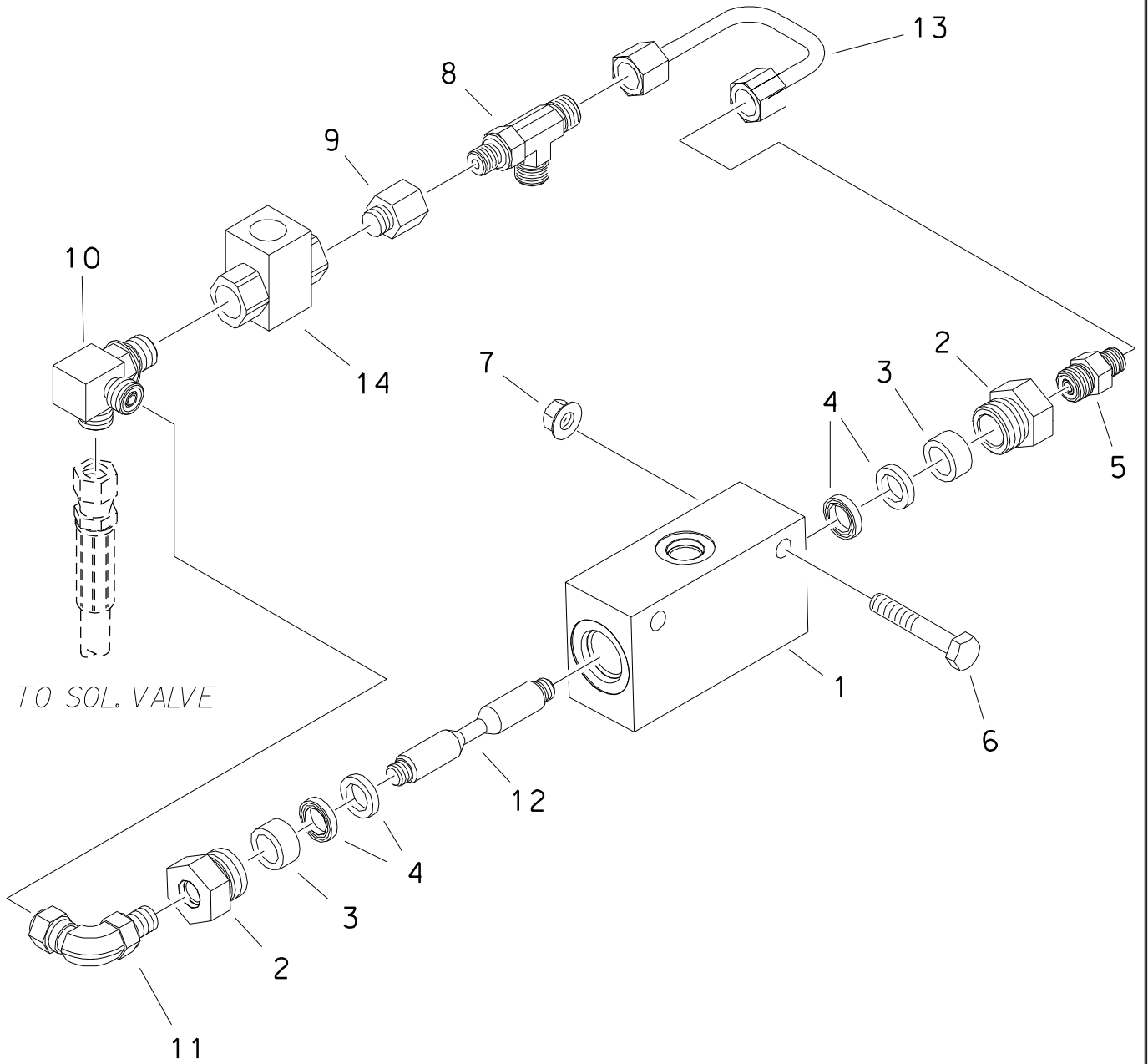



# SELECTOR VALVE

REF NO.	PART NUMBER	QTY	DESCRIPTION	REMARKS
	101-085		GREASER VALVE KIT	INCL. REF. 1-4 & 12
1.	343-291	1	VALVE BODY	
2.	149-152	2	REDUCER (10S-04SF)	
3.	343-292	2	SPACER	
4.	116-880	4	SEAL (POLY PAK)	
5.	154-278	1	CONNECTOR (04S-040)	
6.	106-329	2	SCREW (M8-1.25 X 50MM)	
7.	106-386	2	FLG LOCKNUT (M8-1.25)	
8.	154-316	1	RUN TEE (04S-040-040)	
9.	155-254	1	REDUCER (06S-04SF)	
10.	154-230	1	BRANCH TEE (06S-040-040)	
11.	514-257	1	UNION (04S-040FX90)	
12.	350-690	1	VALVE SPOOL	
13.	149-519	1	HYD LINE	
14.	158-600	1	HYD SHUTTLE VALVE	

FOOTNOTES

NOTE:

REFER TO O-RING CHART (800-301) IN BACK OF THE BOOK FOR REPLACEMENT OF O-RINGS.

# AUTO-LUBER ASSEMBLY

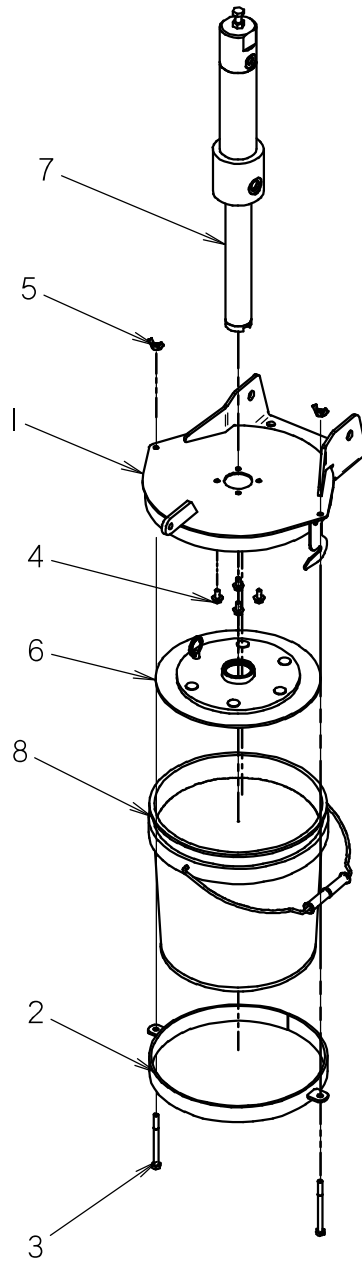

# AUTO-LUBER ASSEMBLY

REF NO.	PART NUMBER	QTY	DESCRIPTION	REMARKS
1	350-400	1	COVER WELDMENT	
2	350-399	1	BASE	
3	105-297	2	BOLT (1/4-NC X 3-1/4")	
4	106-378	4	FLG LK SCREW (M6-1.00 X 12MM)	
5	195-339	2	WING NUT (1/4-NC)	
6	350-1932	1	TOOL JOINT LUBE FOLLOWER	
7	350-398	1	GREASE PUMP PARTS	
8	259-858	1	TOOL JNT LUBE, STD SPRY 2 GAL	
	256-031	-	TOOL JNT LUBE, SUMR SPRY 2 GAL	

NOT SHOWN:

FOOTNOTES:

NOTE:

# GREASE PUMP

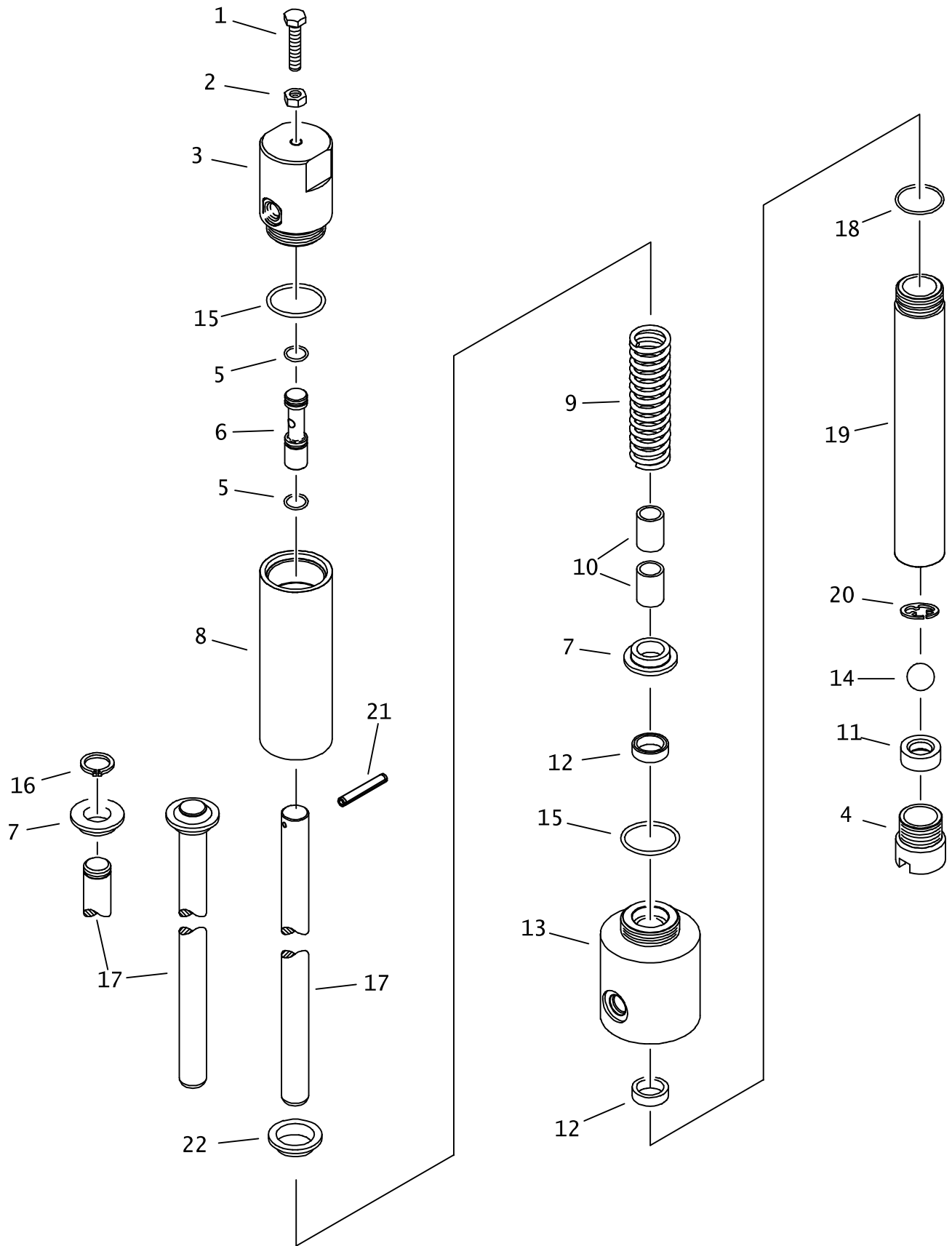

## GREASE PUMP

REF NO.	PART NUMBER	QTY	DESCRIPTION	REMARKS
	350-398		GREASE PUMP PARTS	INCL REF NO'S 1-20
1.	107-492	1	SCREW (M8-1.25 X 35MM, ALL THD)	
2.	106-078	1	NUT (M8-1.25)	
3.	350-686	1	CYLINDER CAP	
4.	350-692	1	INLET TUBE	
5.	157-049	2	O-RING (113 D70)	
6.	350-421	1	ADJUSTING SPOOL	
7.	350-671	1	ROD GUIDE	SEE FOOTNOTE 2
8.	350-682	1	BARREL	
9.	117-228	1	COMPRESSION SPRING	
10.	125-424	2	BRONZE BUSHING (.750")	
11.	350-691	1	VALVE SEAT	SEE FOOTNOTE 1
12.	117-227	2	SEAL (POLY PAK)	
13.	350-687	1	PUMP BODY	
14.	125-125	1	DETENT BALL (.750")	
15.	155-702	2	O-RING (920 D90)	
16.	<del>117-226</del>	-	EXTERNAL SNAP RING (.750")	SEE FOOTNOTE 2
	115-545	-	EXTERNAL SNAP RING (.75")	
17.	<del>350-689</del>	-	PLUNGER	SEE FOOTNOTE 2
	<del>308-603</del>	-	PLUNGER	SEE FOOTNOTE 3
	166-280	1	PLUNGER	
18.	155-748	1	O-RING (916 D90)	
19.	350-693	1	PUMP BARREL	
20.	301-0196	1	RETAINER CLIP	SEE FOOTNOTE 4
21.	105-525	1	ROLL PIN (3/16" X 1/4")	SEE FOOTNOTE 3
22.	178-467	1	ROD CAP	SEE FOOTNOTE 3

NOT SHOWN:

### FOOTNOTES:

1. INSTALL WITH SMALLER BEVEL TOWARD INSIDE OF PUMP
2. 308-603 PLUNGER IS A DIRECT REPLACEMENT OF 350-689 PLUNGER, 117-226 RETAINER R NG, AND AN ADDITIONAL 350-671 ROD GUIDE.
3. USE 166-280, 178-467 & 105-525 TO SUPERSEDE 308-603
4. RETAINER CLIP 301-0196 SUPERSEDES CLIP 105-653

NOTE:

# APPLICATOR

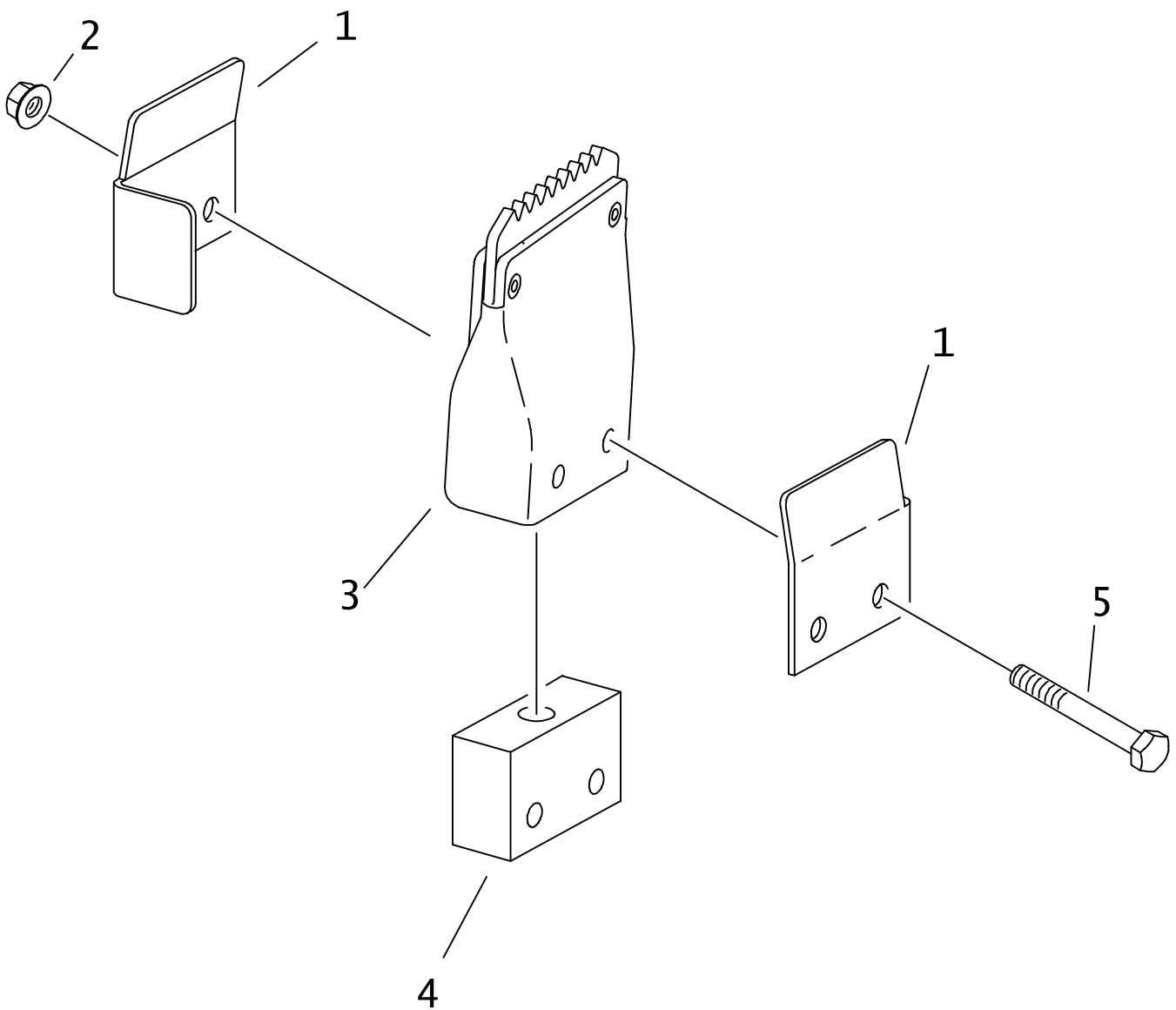

## APPLICATOR

REF NO.	PART NUMBER	QTY	DESCRIPTION	REMARKS
1.	305-911	2	BRACKET, APPLICATOR	
2.	106-385	2	FLG LOCKNUT (M6-1.00)	
3.	306-423	1	WIPER PARTS ASS'Y	
	116-937	1	APPLICATOR	
	107-394	4	WASHER (.375", ALUMINUM)	
	107-395	2	RIVET (.156 X .500) SEMI-TUBUL	
4.	305-912	1	BASE, APPLICATOR	
5.	106-093	2	SCREW (M6-1.00 X 45MM)	

NOT SHOWN:

FOOTNOTES:

NOTE:

# SHUTTLE GUARD MOUNT

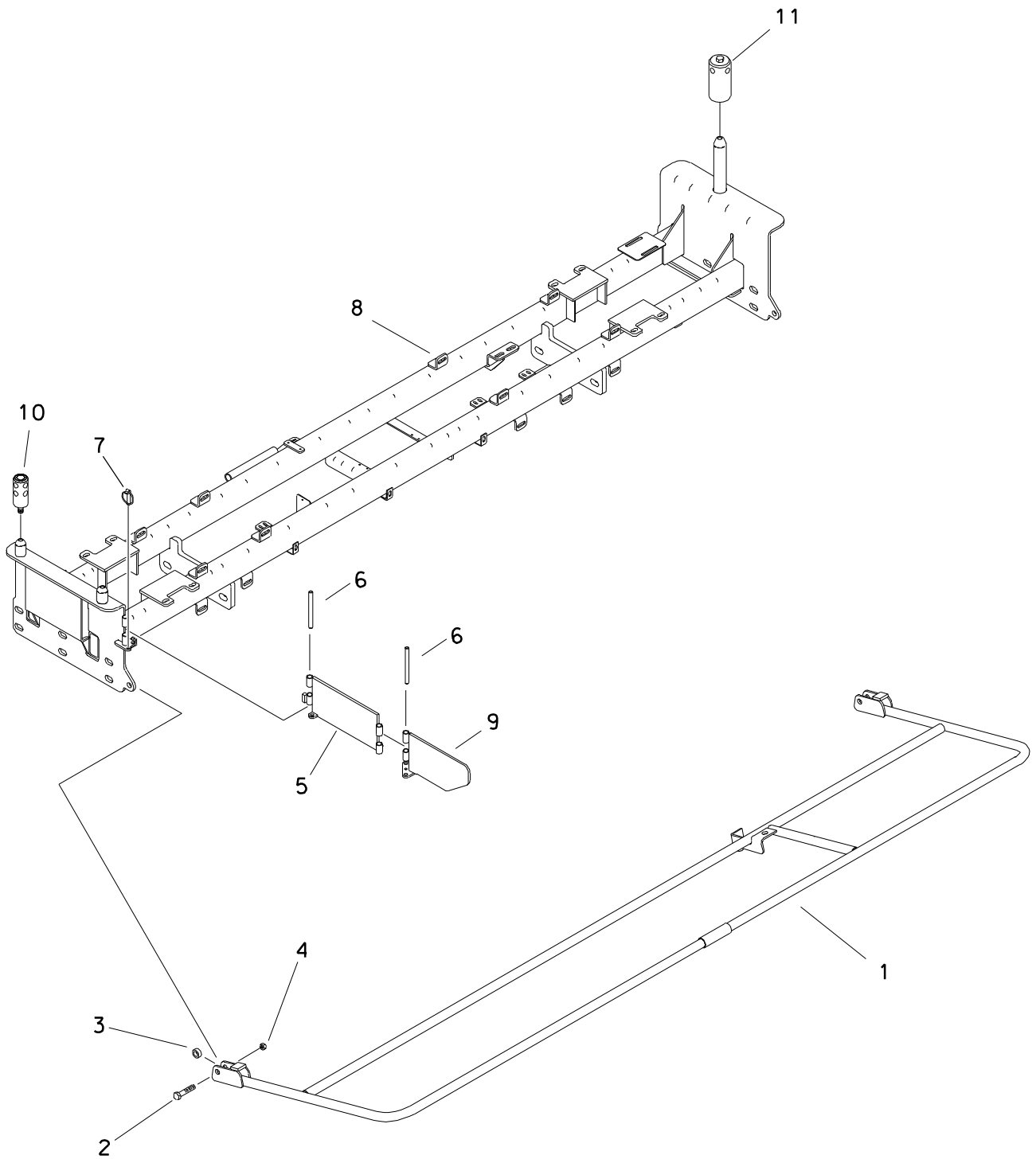



# SHUTTLE GUARD MOUNT

REF NO.	PART NUMBER	QTY	DESCRIPTION	REMARKS
1.	305-409	1	SHUTTLE GUARD	
2.	105-466	2	BOLT (3/4-NC X 2-1/2")	
3.	354-935	2	SPACER	
4.	105-953	2	LOCKNUT (3/4-NC)	
5.	305-405	1	AUXILARY GUIDE	
6.	178-269	2	PIN	
7.	110-228	2	LYNCH PIN (7/16" X 2")	
8.	303-783	-	PIPE LOADER	
9.	310-144	1	GUIDE EXTENSION	
10.	309-613	1	CAP LOCK	
11.	310-260	1	CAP LOCK	

FOOTNOTES

## PIPE LOADER MOUNT

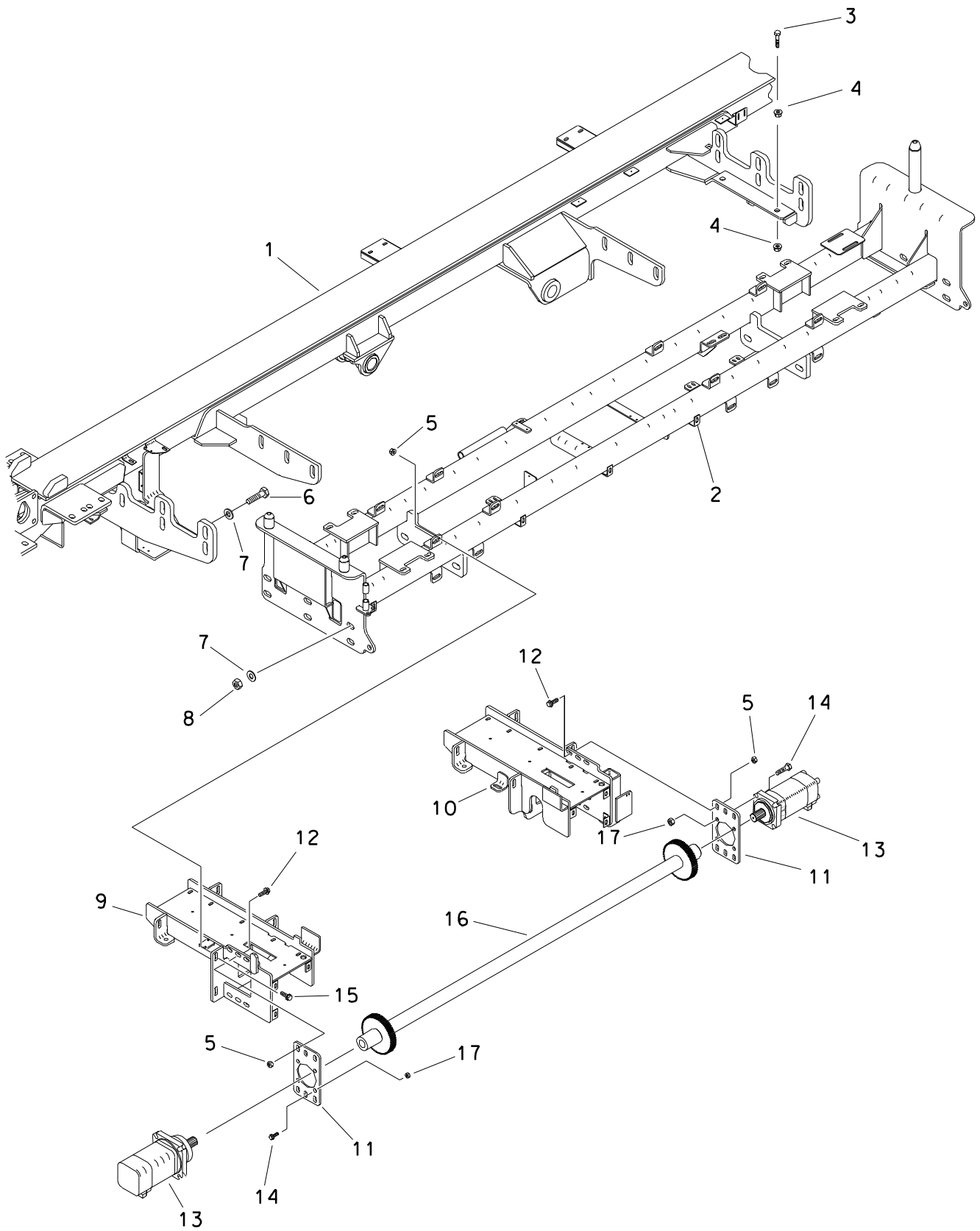

# PIPE LOADER MOUNT

REF NO.	PART NUMBER	QTY	DESCRIPTION	REMARKS
1.	303-648	-	DRILL FRAME WLDMN'T	
2.	303-783	1	PIPE LOADER WELDMENT	
3.	107-226	4	SCREW (M20-2.50 X 120MM, 10.9)	
4.	106-356	8	FLG NUT (M20-2.50, 10.9)	
5.	106-709	24	FLG LOCKNUT (M12-1.75)	
6.	106-474	17	SCREW (M20-2.50 X 60MM)	
7.	105-384	34	WASHER (3/4")	
8.	106-665	17	LOCKNUT (M20-2.50, 10.9)	
9.	350-633	1	SHUTTLE MOUNT, FRONT	
10.	350-632	1	SHUTTLE MOUNT, REAR	
11.	303-815	2	PLATE, MOTOR MOUNT	
12.	107-010	8	FLG LK SCREW (M12-1.75 X 30MM)	
13.	149-975	-	HYD MOTOR	
14.	107-611	8	BOLT (1/2-NC X 1-3/4", SOC)	
15.	107-003	12	FLG LK SCREW (M12-1.75 X 35MM)	
16.	318-579	1	PINION SHAFT	
17.	105-065	8	LOCKNUT (1/2-NC)	

FOOTNOTES

## PIPE LOADER

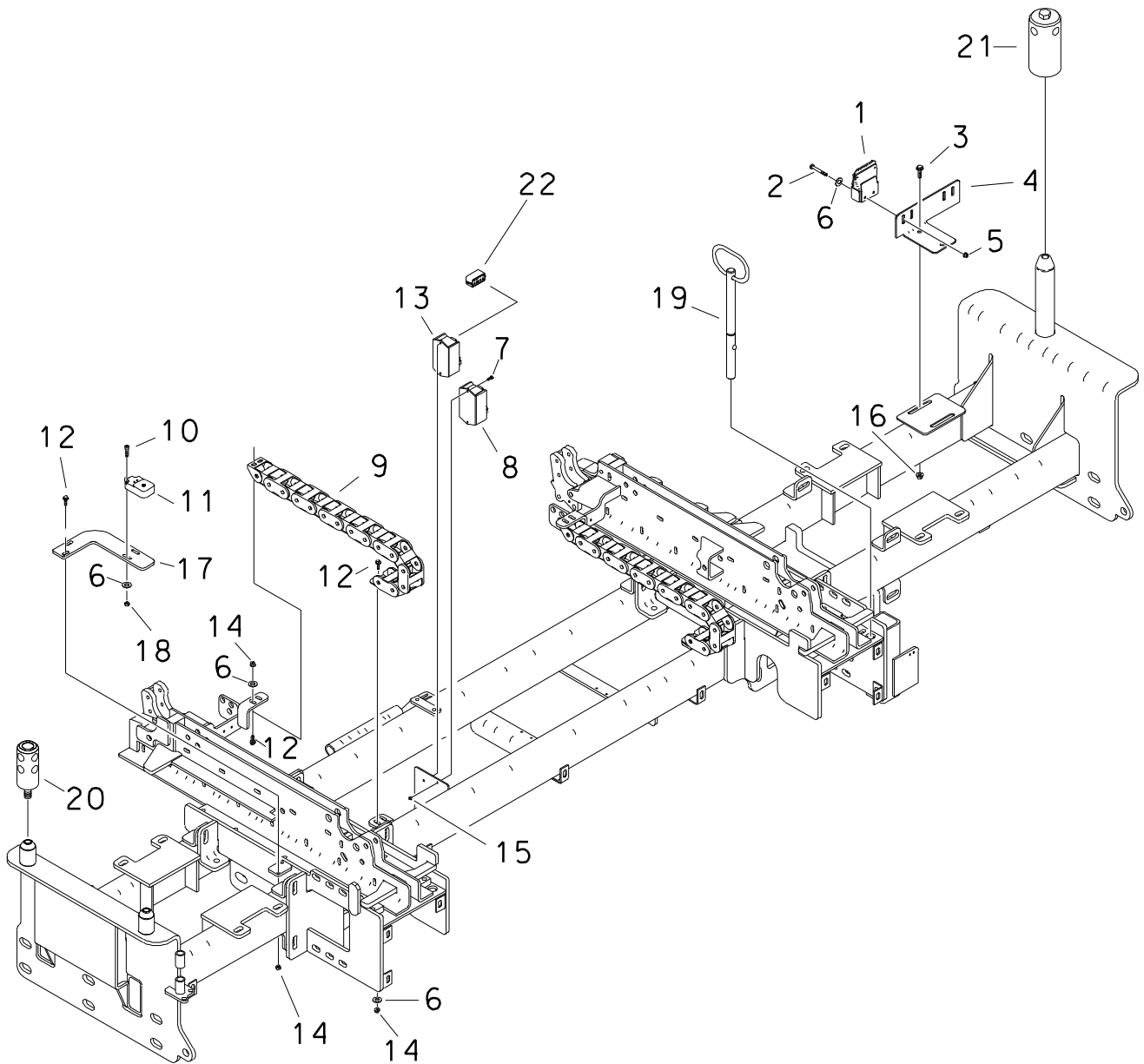

# PIPE LOADER

REF NO.	PART NUMBER	QTY	DESCRIPTION	REMARKS
1.	600-141	-	APPLICATOR SUB ASS'Y	
2.	106-385	2	FLG LOCKNUT (M6-1.00)	
3.	106-724	2	FLG SCREW (M10-1.50 X 25MM)	
4.	305-954	1	BRACKET, WIPER	
5.	106-093	2	SCREW (M6-1.00 X 45MM)	
6.	106-076	14	WASHER (1/4")	
7.	105-185	4	BOLT (#10-24 X 1/2", RD SLT)	
8.	211-025	1	IN-LINE DIODE PACK	
9.	306-746	2	HOSE TRACK	
10.	107-465	2	SCREW (M5-0.80 X 30MM, SOC)	
11.	214-692	1	PROXIMITY SWITCH	
12.	106-640	10	SCREW (M6-1.00 X 20MM, BUT SOC)	
13.	211-026	1	DIODE PACK (DEUTSCH)	
14.	106-237	10	LOCKNUT (M6-1.00, PRV TRO, NLK)	
15.	106-048	4	LOCKNUT (#10-24)	
16.	106-387	2	FLG LOCKNUT (M10-1.50)	
17.	305-734	1	PROXIMITY SWITCH MOUNT	
18.	106-850	2	LOCKNUT (M5-0.80)	
19.	107-449	1	PULL PIN (3/4" X 7-1/2")	
20.	309-613	2	CAP LOCK	
21.	310-260	1	CAP LOCK	
22.	214-781	1	12 WAY PLUG	

FOOTNOTES

## SHUTTLE MOUNT, FRONT

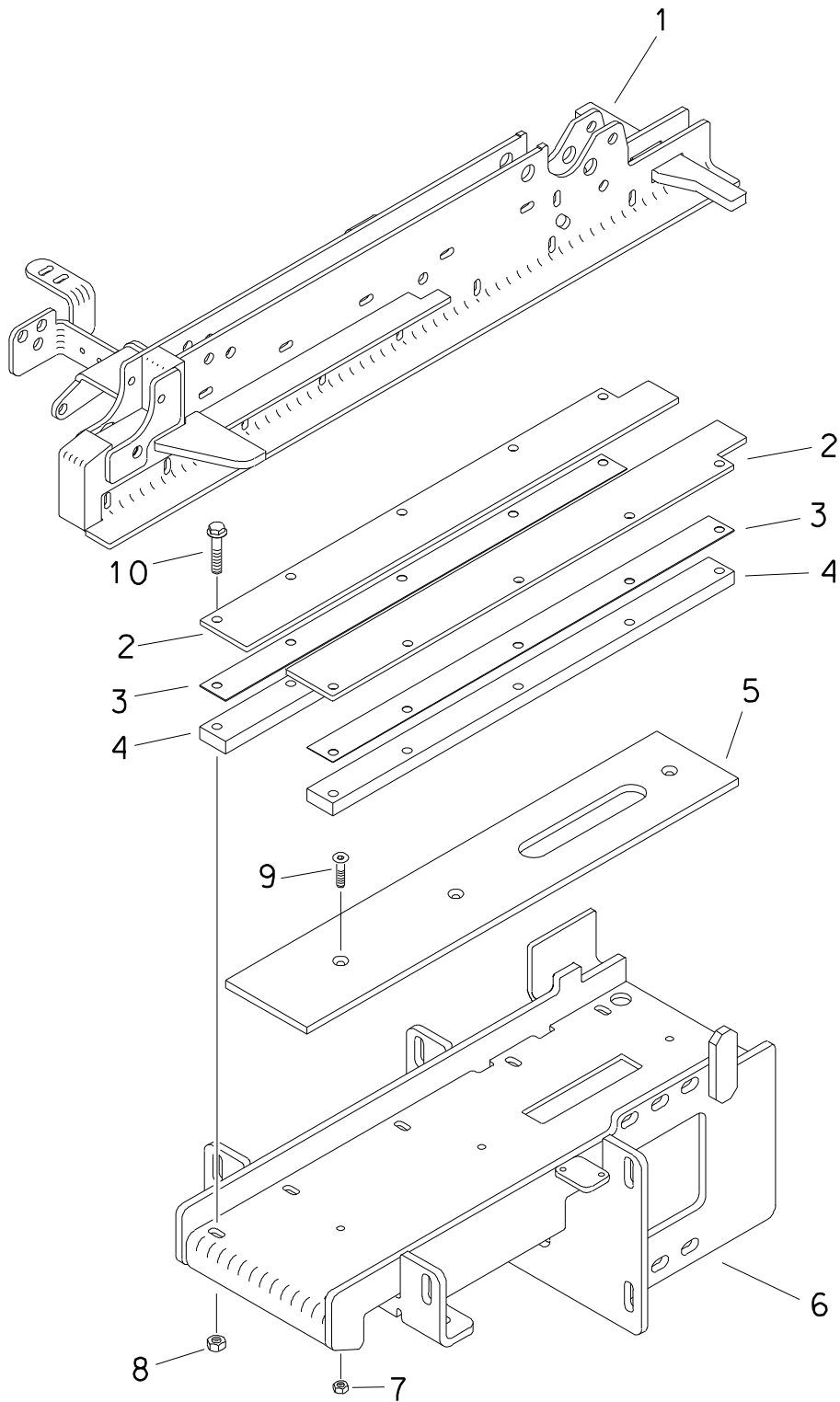

# SHUTTLE MOUNT, FRONT

REF NO.	PART NUMBER	QTY	DESCRIPTION	REMARKS
1.	350-634	-	SHUTTLE FRONT WELDMENT	
2.	305-528	2	BAR, RETAINER	
3.	305-530	4	SPACER BAR	
4.	305-529	2	SPACER BAR	
5.	350-653	1	BEARING PLATE	
6.	350-633	-	SHUTTLE MOUNT, FRONT	
7.	106-386	3	FLG LOCKNUT (M8-1.25)	
8.	105-894	10	LOCKNUT (M10-1.50,PRV TRQ,10.9)	
9.	106-916	3	BOLT (M8-1.25 X 25MM, SOC)	
10.	105-996	10	BOLT (M10-1.50 X 45MM)	

FOOTNOTES

# SHUTTLE MOUNT, FRONT

BEGINS WITH S/N 2V1091

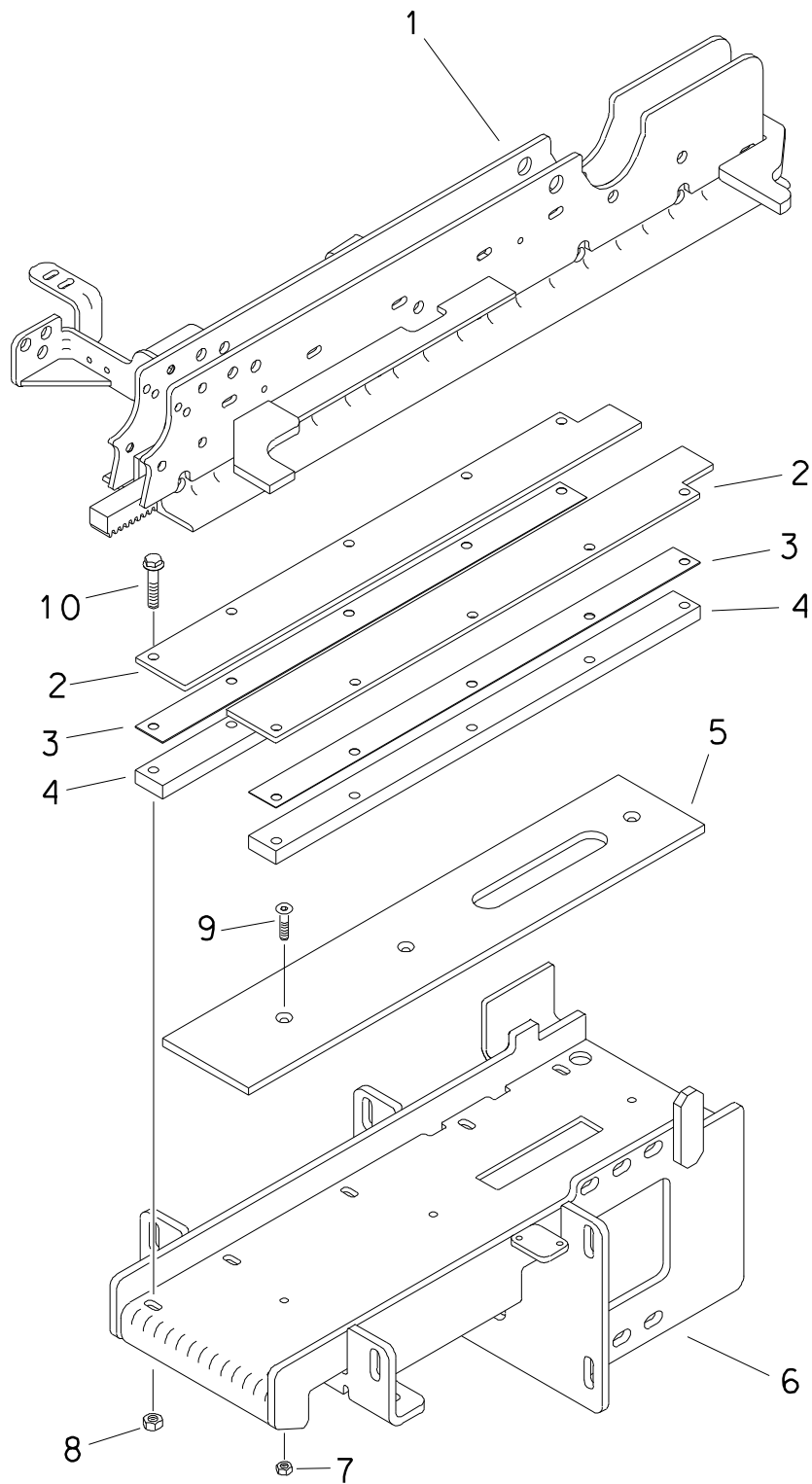



SHUTTLE MOUNT, FRONT  
 BEGINS WITH S/N 2V1091

REF NO.	PART NUMBER	QTY	DESCRIPTION	REMARKS
1.	313-416	-	FRONT SHUTTLE	
2.	305-528	2	BAR, RETAINER	
3.	305-530	4	SPACER BAR	
4.	305-529	2	SPACER BAR	
5.	350-653	1	BEARING PLATE	
6.	350-633	-	SHUTTLE MOUNT, FRONT	
7.	106-386	3	FLG LOCKNUT (M8-1.25)	
8.	105-894	10	LOCKNUT (M10-1.50,PRV TRQ,10.9)	
9.	106-916	3	BOLT (M8-1.25 X 25MM, SOC)	
10.	105-996	10	BOLT (M10-1.50 X 45MM)	

FOOTNOTES

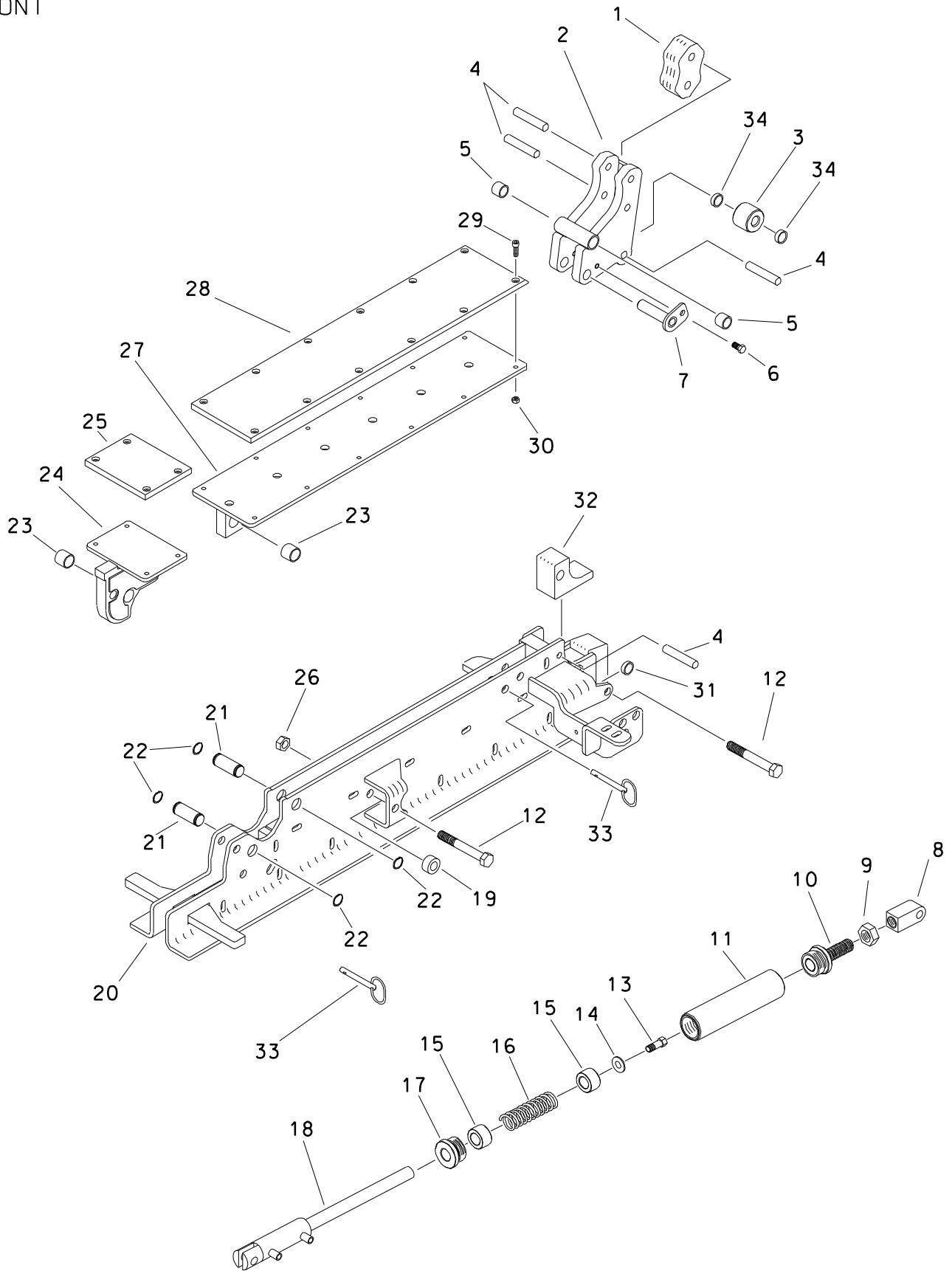
PIPE SHUTTLE  
FRONT

# PIPE SHUTTLE FRONT

REF NO.	PART NUMBER	QTY	DESCRIPTION	REMARKS
1.	309-544	1	GRIPPER PLATE	
2.	350-636	1	LATCH WELDMENT	
3.	370-154	1	ROLLER	
4.	105-507	4	ROLL PIN (3/8" X 2")	
5.	125-469	2	COMPOSITION BUSHING (.500")	
6.	106-378	1	FLG LK SCREW (M6-1.00 X 12MM)	
7.	354-376	1	PIN	
8.	354-357	1	ROD END	
9.	105-310	1	JAM NUT (3/4-NC)	
10.	354-323	1	PLUNGER	
11.	354-355	1	TUBE	
12.	105-250	2	BOLT (1/2-NC X 4.25")	USE LOCTITE 242
13.	105-031	1	BOLT (3/8-NC X 1")	
14.	105-118	1	WASHER (3/8")	
15.	354-356	2	SPRING GUIDE	
16.	117-180	1	COMPRESSION SPRING	
17.	354-432	1	CAP	
18.	149-062	1	CYL ( )	
19.	354-354	1	SPACER	
20.	350-634	1	SHUTTLE FRONT WELDMENT	
21.	178-247	2	SHUTTLE ADJUSTMENT PIN	
22.	115-545	4	EXTERNAL SNAP RING (.75")	
23.	178-294	2	COMPOSITION BUSHING .75 X .75	
24.	303-789	1	AUXILARY PIPE LOADER	
25.	303-809	1	WEAR PLATE	
26.	106-301	2	LOCK NUT (1/2-NC, NLK)	
27.	303-916	1	SUPPORT BAR SHUTTLE	
28.	303-810	1	WEAR STRIP	
29.	106-640	16	BOLT (M6-1.00 X 20MM, BUT SOC)	
30.	106-237	16	LOCKNUT (M6-1.00, PRV TRQ, NLK)	
31.	303-388	1	SPACER	
32.	308-873	1	WEAR INSERT	
33.	183-411	2	COTTERLESS HITCH PIN (.5" X 2")	
34.	125-137	2	BALL BEARING (.375")	

## FOOTNOTES

# PIPE SHUTTLE FRONT (BEGINS WITH S/N 2V1091)

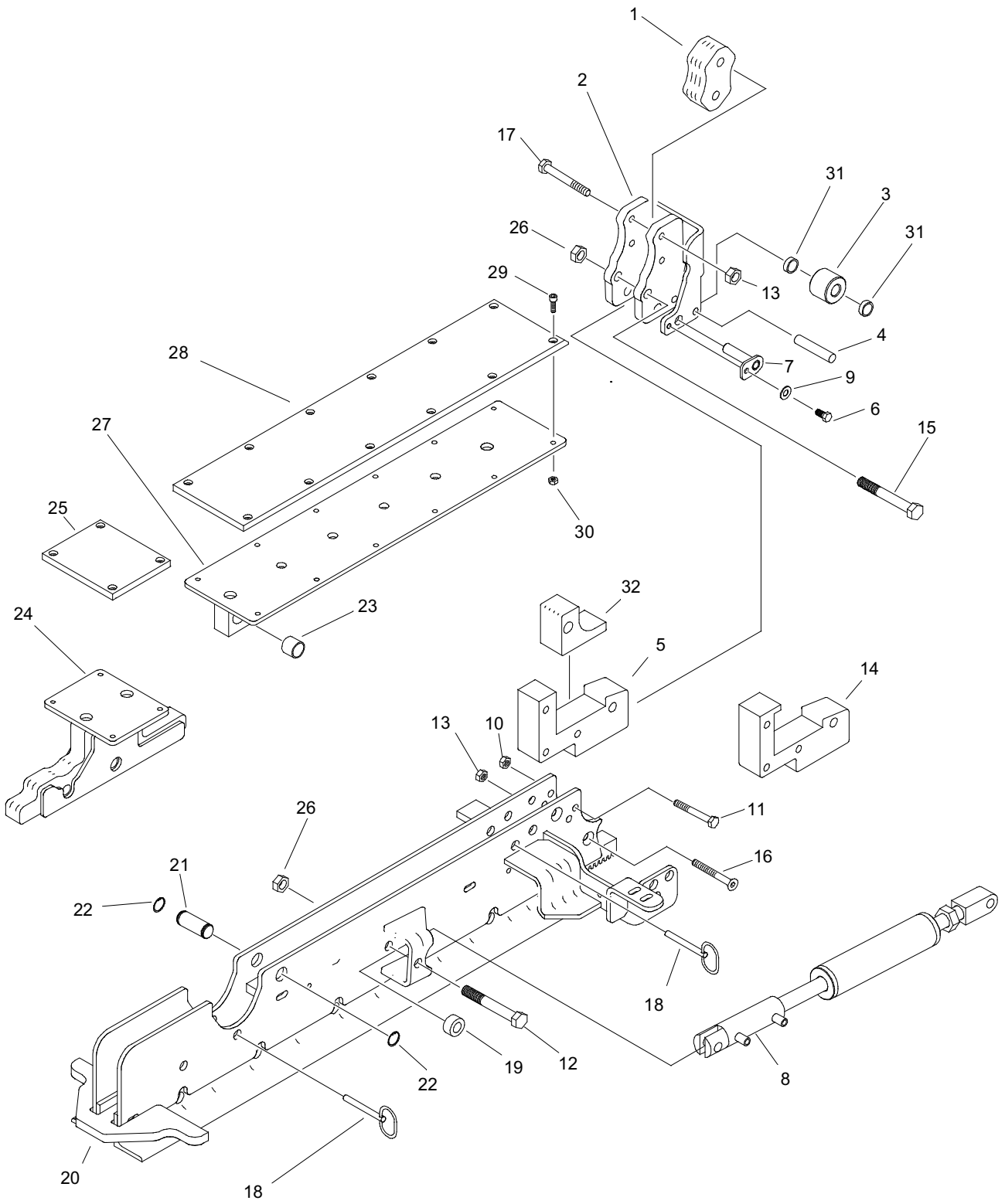

## PIPE SHUTTLE FRONT (BEGINS WITH S/N 2V1091)

REF NO.	PART NUMBER	QTY	DESCRIPTION	REMARKS
1.	307-769	1	GRIPPER PLATE	
2.	313-433	1	FRONT GRIPPER	
3.	370-154	1	ROLLER	
4.	105-507	1	ROLL PIN (3/8" X 2")	
5.	313-444	1	STANDARD NOSE PIECE	
6.	106-378	1	FLG LK SCREW (M6-1.00 X 12MM)	
7.	354-376	1	PIN	
8.	191-161	1	GRIPPER CYLINDER	
9.	106-076	1	WASHER (1/4")	
10.	105-089	1	LOCKNUT (5/16-NC)	
11.	105-178	1	BOLT (5/16-NC X 2-1/2", GD8)	SEE FOOTNOTE 1
12.	105-110	1	BOLT (1/2-NC X 4-1/2")	
13.	105-047	5	LOCKNUT (3/8-NC)	
14.	313-443	1	NOSE PIECE, COBBLE PIPE	
15.	105-300	1	BOLT (1/2-NC X 3-1/4")	
16.	107-691	3	SCRW (3/8-NC X 2-1/2", CSK SOC)	
17.	105-098	2	BOLT (3/8-NC X 3")	
18.	183-411	2	PULL PIN (1/2" X 2")	
19.	354-354	1	SPACER	
20.	313-416	1	FRONT SHUTTLE	
21.	179-141	1	PIVOT PIN	
22.	115-503	2	KLIP RING (.750")	
23.	125-424	1	BRONZE BUSHING (.750")	
24.	313-445	1	AUXILIARY PIPE LOADER	
25.	313-466	1	AUXILIARY SLIDE PLATE	
26.	106-301	2	LOCK NUT (1/2-NC, NLK)	
27.	313-446	1	ADJUSTABLE SUPPORT BAR	
28.	313-467	1	SUPPORT SLIDE PLATE	
29.	106-640	16	BOLT (M6-1.00 X 20MM, BUT SOC)	
30.	106-237	16	LOCKNUT (M6-1.00, PRV TRQ, NLK)	
31.	125-137	2	BALL BEARING (.375")	
32.	313-487	1	WEAR PAD	

NOT SHOWN:

#### FOOTNOTES:

I. BOLT WILL BE INSTALLED IN THE UPPER HOLE AS SHOWN WITH REF NO. 5 AND WILL BE INSTALLED IN THE HOLE WITH REF NO. 14.

NOTE:

## SHUTTLE MOUNT, REAR

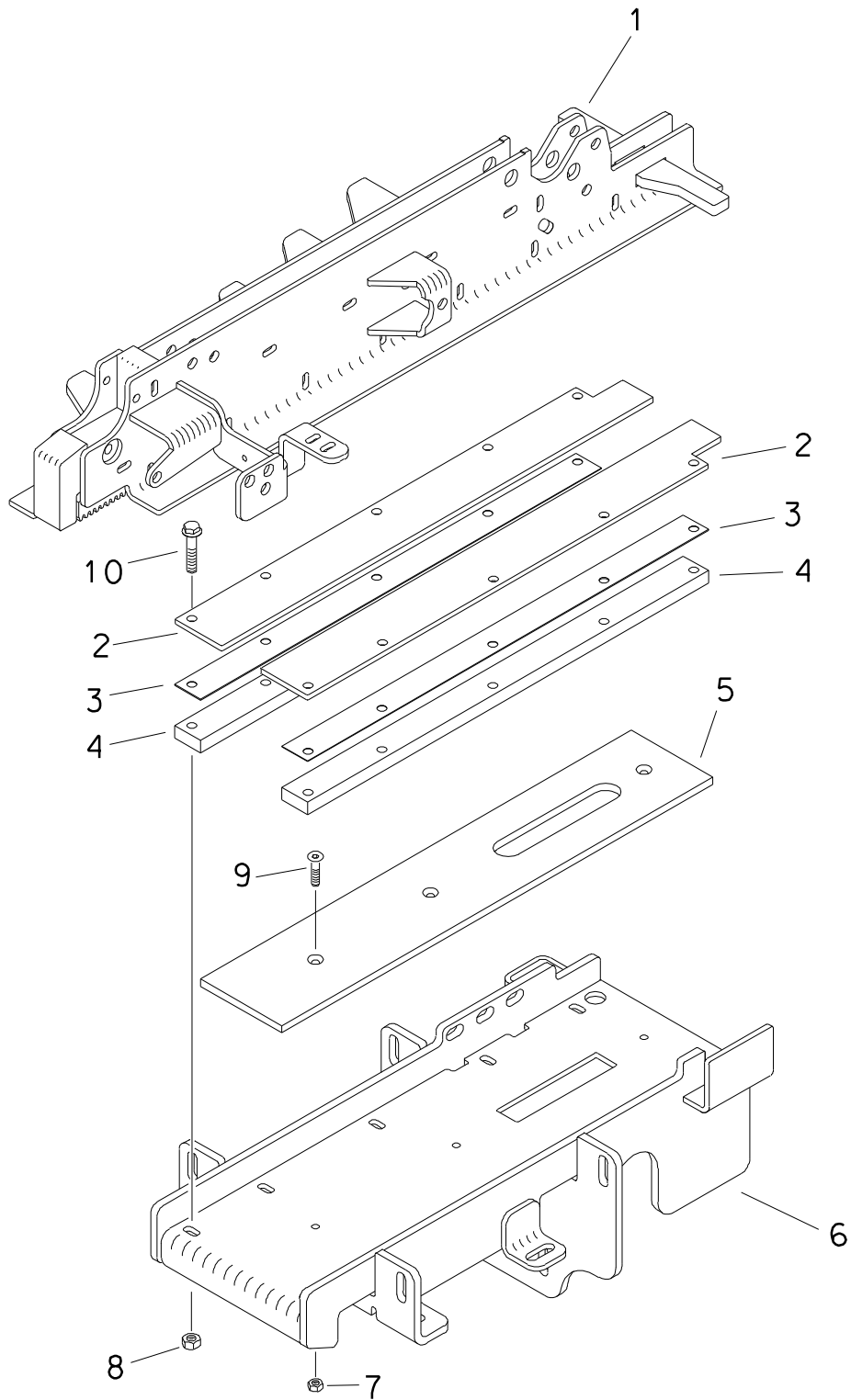

# SHUTTLE MOUNT, REAR

REF NO.	PART NUMBER	QTY	DESCRIPTION	REMARKS
1.	350-635	-	REAR SHUTTLE WELDMENT	
2.	305-528	2	BAR, RETAINER	
3.	305-530	4	SPACER BAR	
4.	305-529	2	SPACER BAR	
5.	350-653	1	BEARING PLATE	
6.	350-632	-	SHUTTLE MOUNT (REAR)	
7.	106-386	3	FLG LOCKNUT (M8-1.25)	
8.	105-894	10	LOCKNUT (M10-1.50,PRV TRQ,10.9)	
9.	106-916	3	SCREW (M8-1.25 X 25MM, SOC)	
10.	105-996	10	SCREW (M10-1.50 X 45MM)	

FOOTNOTES

# SHUTTLE MOUNT, REAR

BEGINS WITH S/N 2V1091

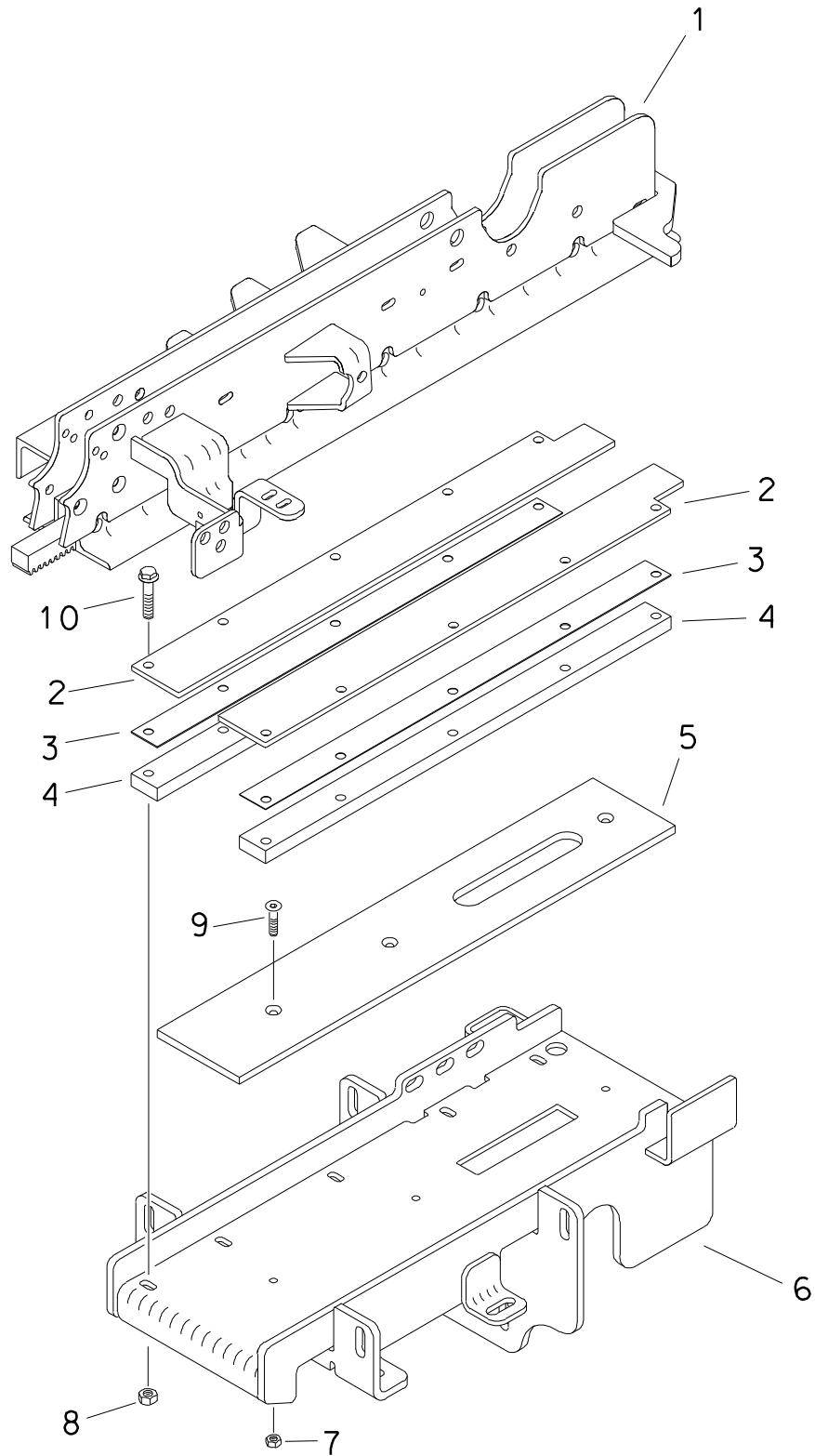



SHUTTLE MOUNT, REAR  
 BEGINS WITH S/N 2V1091

REF NO.	PART NUMBER	QTY	DESCRIPTION	REMARKS
1.	313-289	-	REAR SHUTTLE	
2.	305-528	2	BAR, RETAINER	
3.	305-530	4	SPACER BAR	
4.	305-529	2	SPACER BAR	
5.	350-653	1	BEARING PLATE	
6.	350-632	-	SHUTTLE MOUNT (REAR)	
7.	106-386	3	FLG LOCKNUT (M8-1.25)	
8.	105-894	10	LOCKNUT (M10-1.50,PRV TRQ,10.9)	
9.	106-916	3	SCREW (M8-1.25 X 25MM, SOC)	
10.	105-996	10	SCREW (M10-1.50 X 45MM)	

FOOTNOTES

# PIPE SHUTTLE REAR

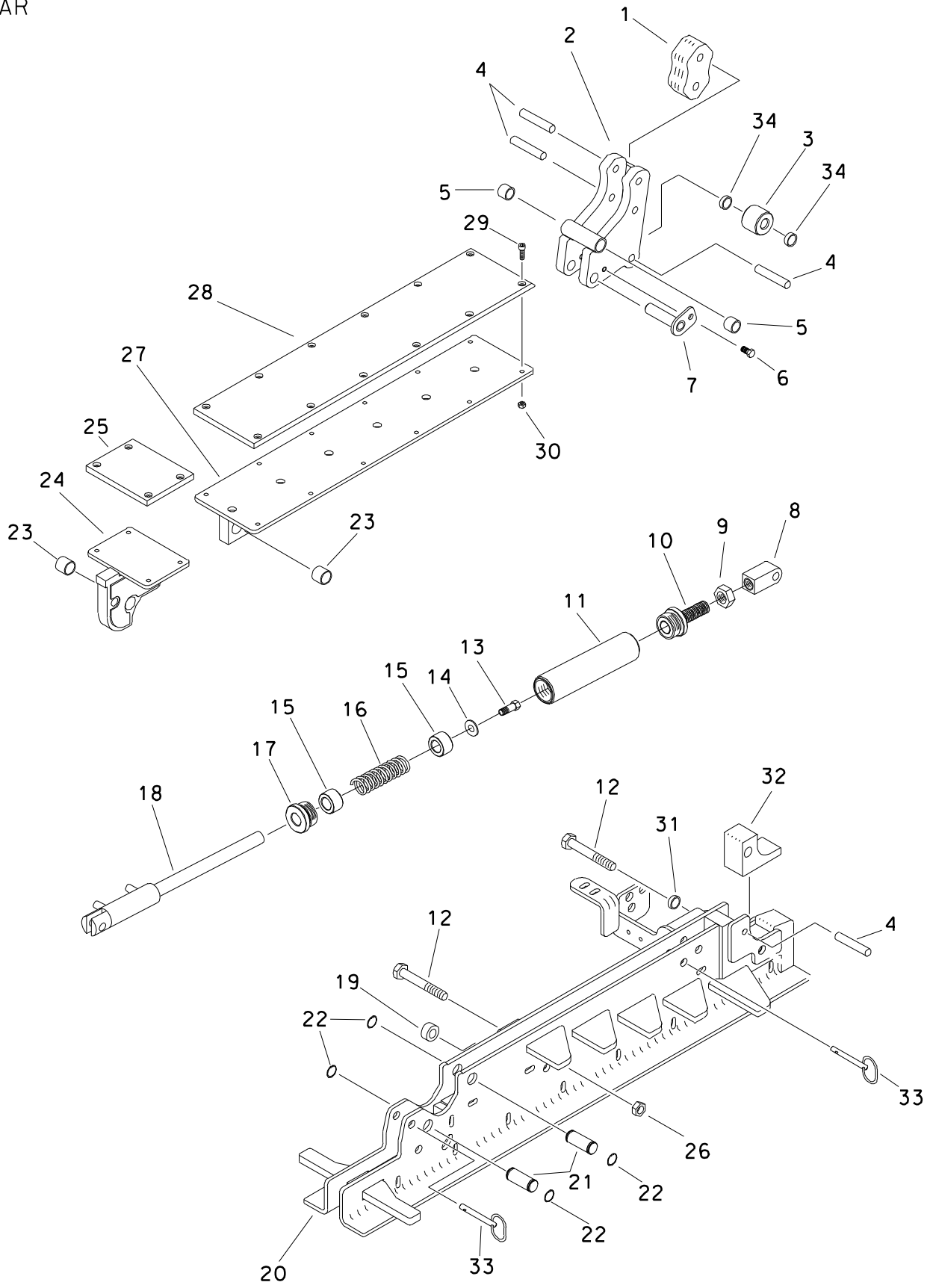

# PIPE SHUTTLE REAR

REF NO.	PART NUMBER	QTY	DESCRIPTION	REMARKS
1.	309-544	1	GRIPPER PLATE	
2.	350-636	1	LATCH WELDMENT	
3.	370-154	1	ROLLER	
4.	105-507	4	ROLL PIN (3/8" X 2")	
5.	125-469	2	COMPOSITION BUSHING (.500")	
6.	106-378	1	FLG LK SCREW (M6-1.00 X 12MM)	
7.	354-376	1	PIN	
8.	354-357	1	ROD END	
9.	105-310	1	JAM NUT (3/4-NC)	
10.	354-323	1	PLUNGER	
11.	354-355	1	TUBE	
12.	105-250	2	BOLT (1/2-NC X 4.25")	USE LOCTITE 242
13.	105-031	1	BOLT (3/8-NC X 1")	
14.	105-118	1	WASHER (3/8")	
15.	354-356	2	SPRING GUIDE	
16.	117-180	1	COMPRESSION SPRING	
17.	354-432	1	CAP	
18.	149-062	1	CYL ( )	
19.	354-354	1	SPACER	
20.	350-635	1	SHUTTLE REAR WELDMENT	
21.	178-247	2	SHUTTLE ADJUSTMENT PIN	
22.	115-545	4	EXTERNAL SNAP RING (.75")	
23.	178-294	2	COMPOSITION BUSHING .75 X .75	
24.	303-789	1	AUXILARY PIPE LOADER	
25.	303-809	1	WEAR PLATE	
26.	106-301	2	LOCKNUT (1/2-NC, NLK)	
27.	303-916	1	SUPPORT BAR SHUTTLE	
28.	303-810	1	WEAR STRIP	
29.	106-640	16	SCREW (M6-1.00 X 20MM, BUT SOC)	
30.	106-237	16	LOCKNUT (M6-1.00, PRV TRQ, NLK)	
31.	303-388	1	SPACER	
32.	308-873	1	WEAR INSERT	
33.	183-411	2	COTTERLESS HITCH PIN (.5" X 2")	
34.	125-137	2	BALL BEARING (.375")	

FOOTNOTES



## PIPE SHUTTLE REAR (BEGIN WITH S/N 2V1091)

REF NO.	PART NUMBER	QTY	DESCRIPTION	REMARKS
1.	307-769	1	GRIPPER PLATE	
2.	313-434	1	REAR GRIPPER	
3.	370-154	1	ROLLER	
4.	105-507	1	ROLL PIN (3/8" X 2")	
5.	313-444	1	STANDARD NOSE PIECE	
6.	106-378	1	FLG LK SCREW (M6-1.00 X 12MM)	
7.	354-376	1	PIN	
8.	191-161	1	GRIPPER CYLINDER	
9.	106-076	1	WASHER (1/4")	
10.	105-089	1	LOCKNUT (5/16-NC)	
11.	105-178	1	BOLT (5/16-NC X 2-1/2", GD8)	SEE FOOTNOTE 1
12.	105-110	1	BOLT (1/2-NC X 4-1/2")	
13.	105-047	5	LOCKNUT (3/8-NC)	
14.	313-443	1	NOSE PIECE, COBBLE PIPE	
15.	105-300	1	BOLT (1/2-NC X 3-1/4")	
16.	107-691	3	SCRW (3/8-NC X 2-1/2", CSK SOC)	
17.	105-098	2	BOLT (3/8-NC X 3")	
18.	183-411	2	COTTERLESS HITCH PIN (.5" X 2")	
19.	354-354	1	SPACER	
20.	313-289	1	REAR SHUTTLE	
21.	179-141	1	PIVOT PIN	
22.	115-503	2	EXTERNAL CLIP RING (.750")	
23.	125-424	1	BRONZE BUSHING (.750")	
24.	313-445	1	AUXILIARY PIPE LOADER	
25.	313-466	1	AUXILIARY SLIDE PLATE	
26.	106-301	2	LOCK NUT (1/2-NC, NLK)	
27.	313-446	1	ADJUSTABLE SUPPORT BAR	
28.	313-467	1	SUPPORT SLIDE PLATE	
29.	106-640	16	BOLT (M6-1.00 X 20MM, BUT SOC)	
30.	106-237	16	LOCKNUT (M6-1.00, PRV TRQ, NLK)	
31.	125-137	2	BALL BEARING (.375")	
32.	313-487	1	WEAR PAD	

NOT SHOWN:

#### FOOTNOTES:

1. BOLT WILL BE INSTALLED IN THE UPPER HOLE AS SHOWN WITH REF NO. 5 AND WILL BE INSTALLED IN THE LOWER HOLE WITH REF NO. 14.

NOTE:

## PIPE LOADER COVERS

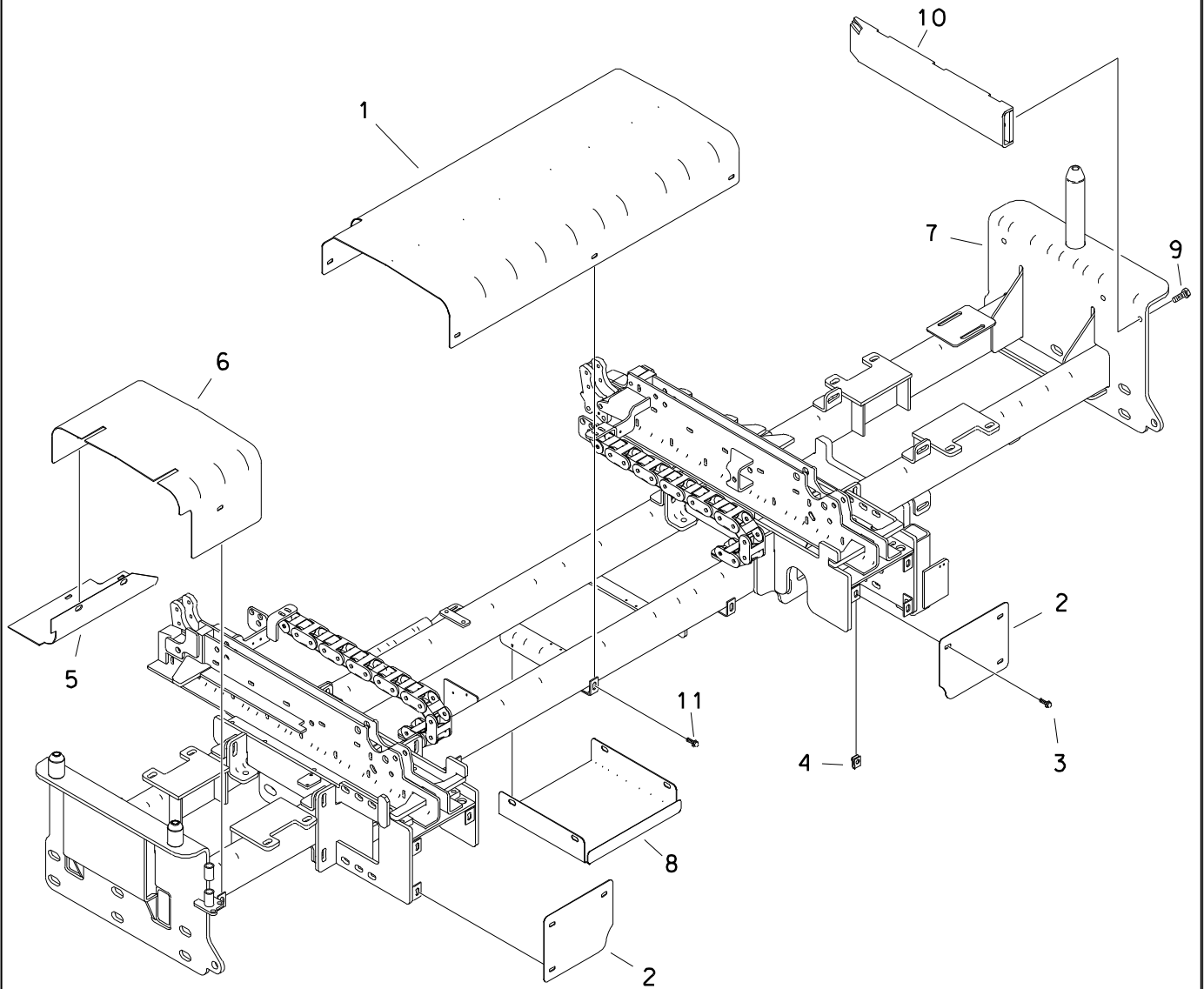

# PIPE LOADER COVERS

REF NO.	PART NUMBER	QTY	DESCRIPTION	REMARKS
1.	305-680	1	MIDDLE COVER, AT	
2.	307-380	2	PINION COVER	
3.	106-380	6	FLG LK SCREW (M8-1.25 X 20MM)	
4.	106-551	20	CLIP NUT (M8-1.25)	
5.	307-322	1	COVER	
6.	307-321	1	FRONT COVER	
7.	303-783	1	PIPE LOADER WELDMENT	
8.	310-905	1	VALVE COVER	
9.	106-469	3	FLG SCREW (M12-1.75 X 30MM)	USED ON JT2720 MACH 1 ALL TERRAIN ONLY
10.	310-690	1	GUIDE CHANNEL	USED ON JT2720 MACH 1 ALL TERRAIN ONLY
11.	106-162	15	FLG SCREW (M8-1.25 X 20MM)	

FOOTNOTES

## PIPE LOADER LIFTERS

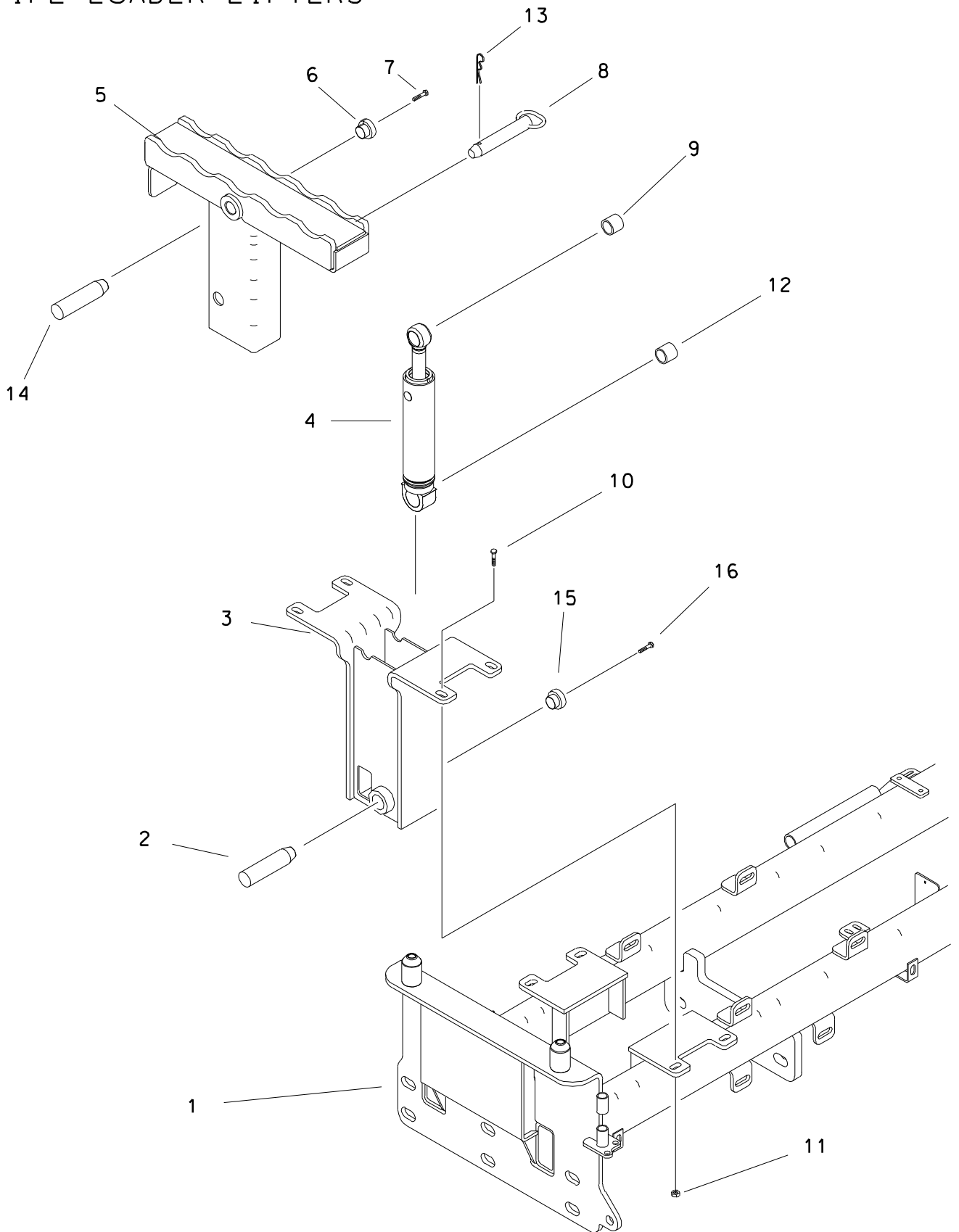



# PIPE LOADER LIFTERS

REF NO.	PART NUMBER	QTY	DESCRIPTION	REMARKS
1.	303-783	-	PIPE LOADER WELDMENT	
2.	183-863	2	TAPERED PIN (31.8MM X 128MM)	
3.	303-997	2	LIFTER OUTER TUBE	
4.	151-031	2	CYLINDER (2" X 1" X 8")	
5.	303-996	2	PIPE LIFTER	
6.	181-981	2	TAPERED INSERT (1")	
7.	106-724	2	FLG SCREW (M10-1.50 X 25MM)	
8.	183-110	2	PULL PIN (3/4" X 4-1/2")	
9.	125-770	2	COMPOSITION BUSHING (1")	
10.	107-003	8	FLG LK SCREW (M12-1.75 X 35MM)	
11.	106-709	8	FLANGE NUT (M12-1.75)	
12.	125-771	2	COMPOSITION BUSHING (1.25")	
13.	110-128	2	SPRING CLIP PIN (5/32" X 1")	
14.	179-024	2	TAPERED PIN (25.4MM X 117MM)	
15.	181-982	2	TAPERED INSERT (1.25")	
16.	106-469	2	FLG SCREW (M12-1.75 X 30MM)	

FOOTNOTES

## SHUTTLE STOP

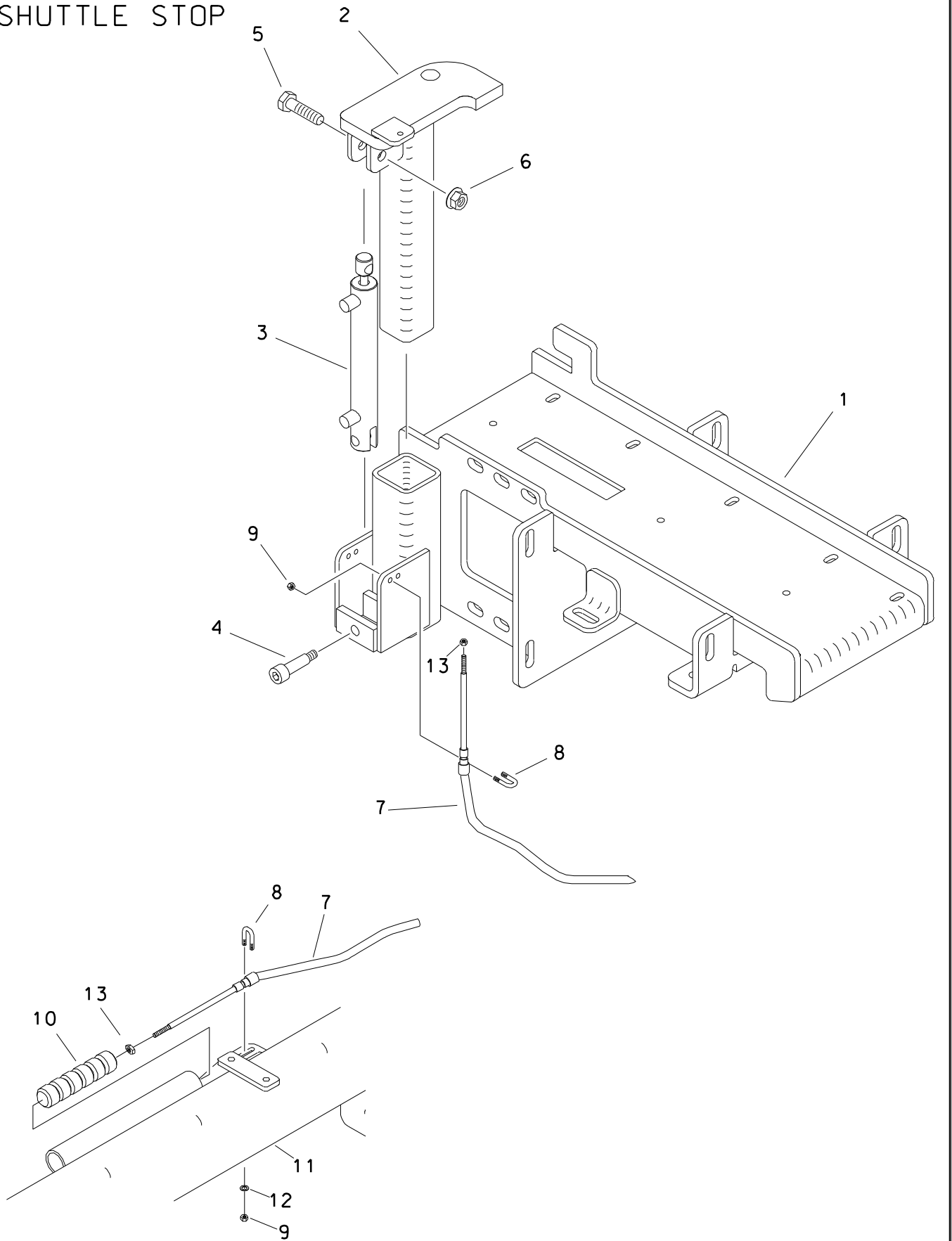

# SHUTTLE STOP

REF NO.	PART NUMBER	QTY	DESCRIPTION	REMARKS
1.	350-632	-	SHUTTLE MOUNT, REAR	
2.	303-819	1	ROW SELECT STOP	
3.	150-727	1	CYL (1.0" X .500" X 4.0")	
4.	106-095	1	SHLD BLT (1/2" X 1-3/4", 3/8-NC)	
5.	106-196	1	BOLT (1/2-NC X 2")	
6.	105-065	1	LOCKNUT (1/2-NC)	
7.	194-198	1	CONTRQL CABLE	
8.	106-630	2	U-BOLT (#10-24 X 5/16")	
9.	105-186	4	NUT (#10-24)	
10.	309-213	1	ROW SELECT INDICATOR	
11.	303-783	-	PIPE LOADER WELDMENT	
12.	106-076	2	WASHER (1/4")	
13.	106-138	2	NUT (M5-0.80)	

FOOTNOTES

# SHUTTLE MOTOR HYDRAULICS

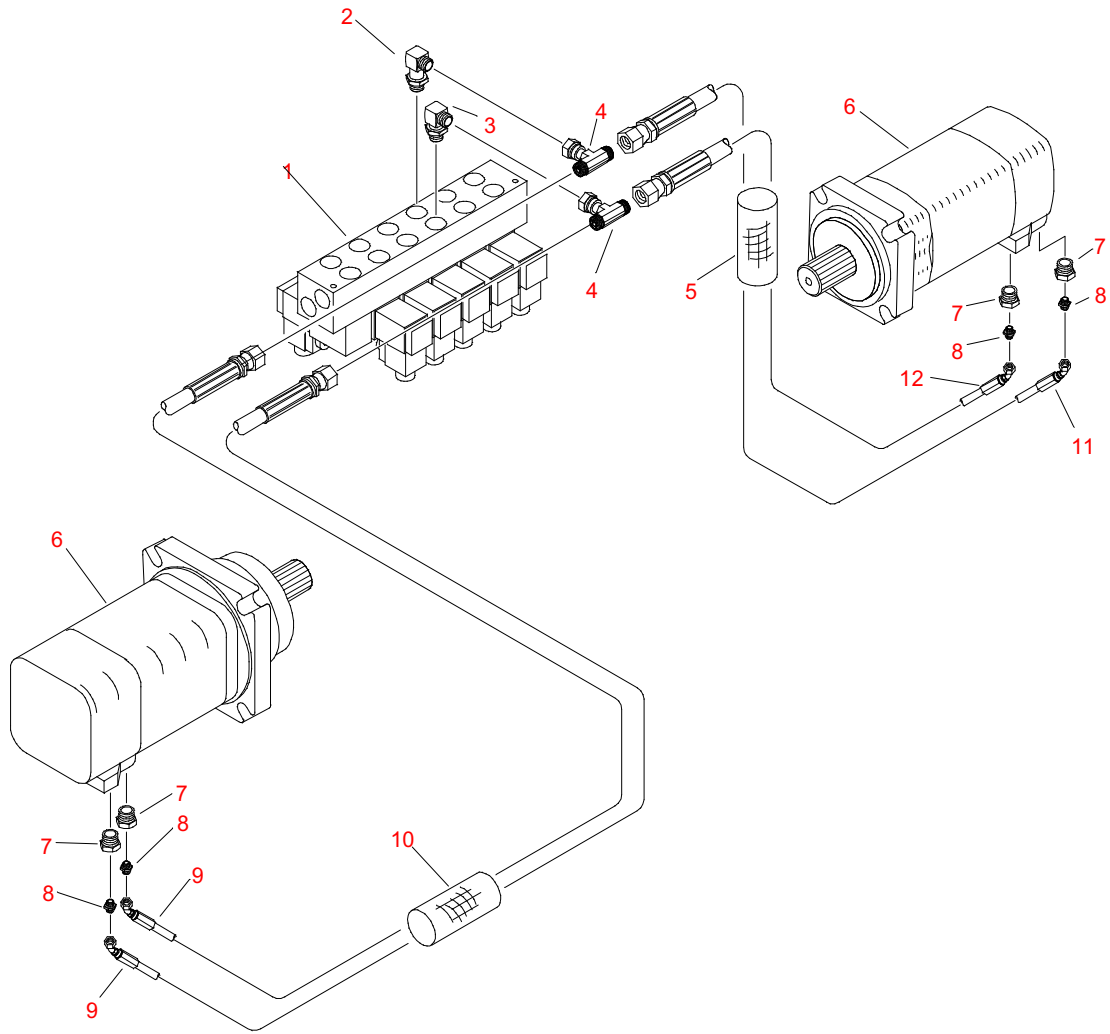

## SHUTTLE MOTOR HYDRAULICS

REF NO.	PART NUMBER	QTY	DESCRIPTION	REMARKS
1.	153-095	-	HYD VALVE	BEFORE S/N: CMWJ27T2K60000038 AFTER S/N: CMWJ27T2K60000039
	153-741	-	HYD VALVE	
2.	154-474	1	CONNECTOR (04S-04090, XL)	
3.	154-252	1	CONNECTOR (04S-04090)	
4.	154-379	2	UN BR TEE (040FX-040-040)	
5.	115-813	1	ABRASION SLEEVE (1.59" X 36")	
6.	149-975	2	HYD MOTOR	
7.	155-181	4	REDUCER (10S-04SF)	
8.	154-278	4	CONNECTOR (04S-040)	
9.	154-898	2	HOSE (040FX45-54"-3000)	
10.	117-657	1	ABRASION SLEEVE (1.59" X 54")	
11.	515-020	1	HOSE (040FX45-36"-3000)	
12.	153-317	1	HOSE (040FX45-35"-3000)	

NOT SHOWN:

FOOTNOTES:

NOTE:

REFER TO O-RING CHART (800-301) IN BACK OF BOOK FOR REPLACEMENT OF O-RINGS.

## SHUTTLE MOTOR CASE DRAIN

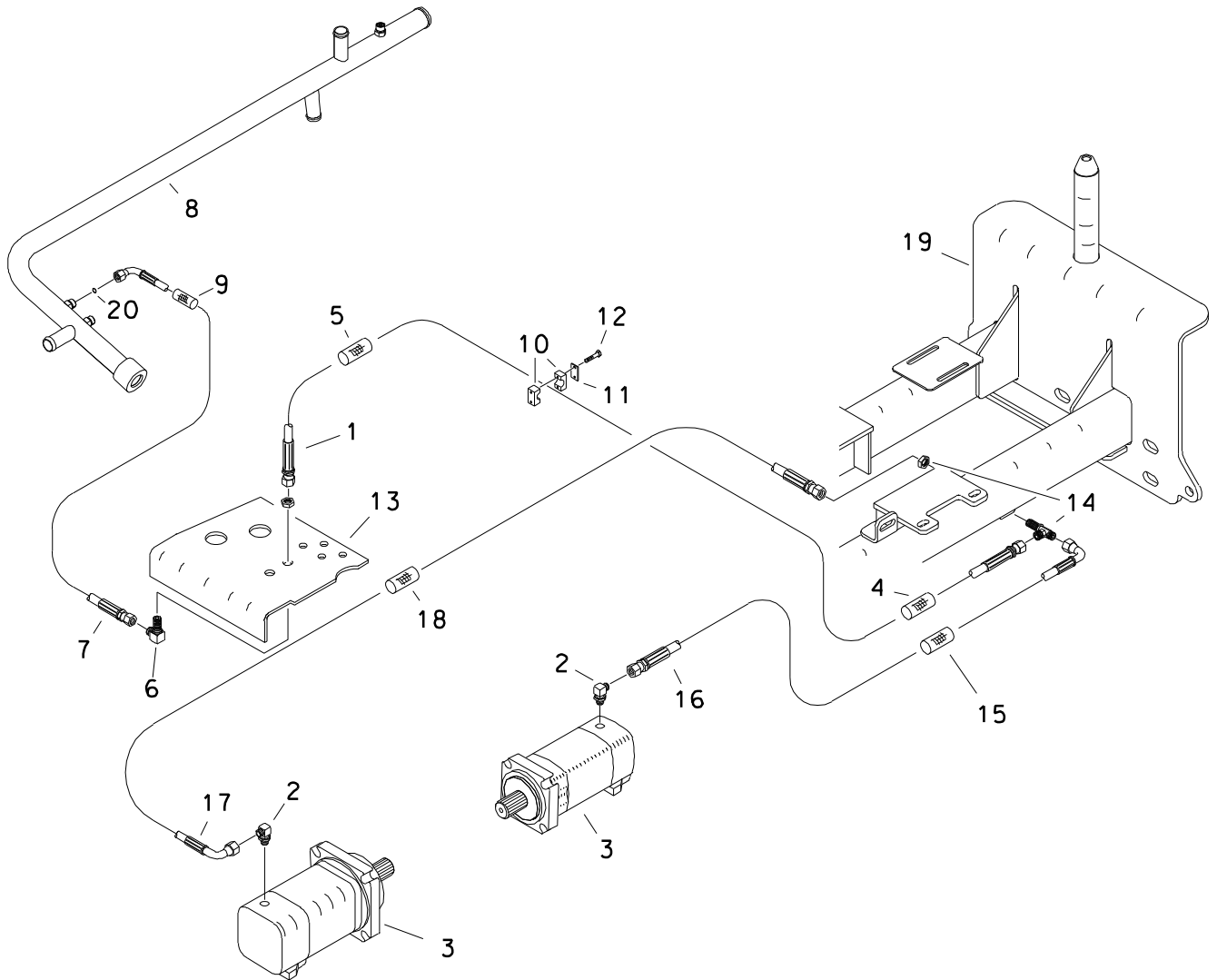

# SHUTTLE MOTOR CASE DRAIN

REF NO.	PART NUMBER	QTY	DESCRIPTION	REMARKS
1.	154-777	1	HOSE (060FX-98"-3000)	
2.	514-049	2	CONNECTOR (04S-06090)	
3.	149-975	2	HYD MOTOR	
4.	117-718	1	ABRASION SLEEVE (1.00" X 36")	
5.	117-326	1	ABRASION SLEEVE (1.00" X 58")	
6.	154-229	1	BK CONNECTOR (060-06090BK)	
7.	515-716	1	HOSE (060FX90-42"-3000)	
8.	156-905	1	HYD LINE (24)	
9.	117-717	1	ABRASION SLEEVE (1.00" X 40")	
10.	110-879	1	BLT-ON CLP(5/8", SOLD PER SET)	
11.	110-958	1	BACKUP PLATE	
12.	105-818	2	BOLT (1/4-NC X 1-1/2")	
13.	305-710	-	MAIN FRAME	
14.	154-400	1	BK RUN TEE (060-060-060BK)	
15.	117-672	1	ABRASION SLEEVE (1.00" X 20")	
16.	149-559	1	HOSE (060FX90M-20"-3000)	
17.	153-306	1	HOSE (060FX90S-130"-3000)	
18.	117-399	1	ABRASION SLEEVE (1.00" X 130")	
19.	303-783	-	PIPE LOADER WELDMENT	
20.	157-038	1	O-RING (012 D90)	

FOOTNOTES

NOTE:  
REFER TO O-RING CHART (800-301) IN BACK OF THE BOOK FOR REPLACEMENT OF O-RINGS

# AUX. VALVE/PIPE LIFTER HYDRAULICS

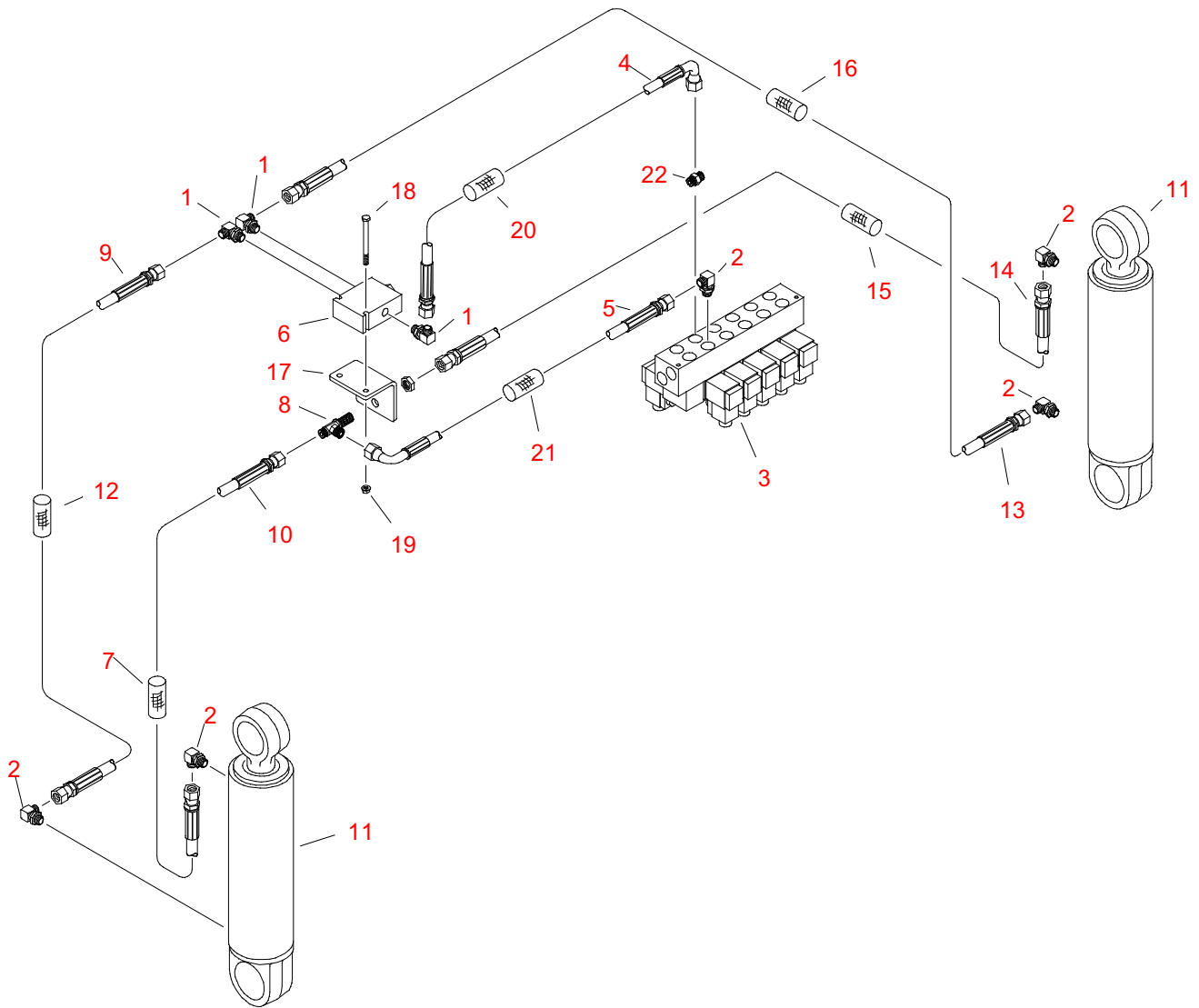



## AUX. VALVE/PIPE LIFTER HYDRAULICS

REF NO.	PART NUMBER	QTY	DESCRIPTION	REMARKS
1.	154-226	3	CONNECTOR (040-06S90)	
2.	154-252	5	CONNECTOR (04S-04090)	
3.	153-095	1	HYD VALVE	BEFORE S/N: CMWJT27T2K60000038
	153-741	1	HYD VALVE	AFTER S/N: CMWJT27T2K60000039
4.	154-802	1	HOSE (040FX90-26"-3000)	
5.	515-744	1	HOSE (040FX90S-28"-3000)	
6.	516-087	1	FLOW DIVIDER	
7.	117-218	1	ABRASION SLEEVE (1.00" x 52")	
8.	154-424	1	BK RUN TEE (040-040-040BK)	
9.	515-013	1	HOSE (040FX-42"-3000)	
10.	153-310	1	HOSE (040FX-52"-3000)	
11.	151-031	2	CYL (2.0" x 1.0" x 8.0")	
12.	117-387	1	ABRASION SLEEVE (1.00" x 42")	
13.	515-099	1	HOSE (040FX-72"-3000)	
14.	154-724	1	HOSE (040FX-82"-3000)	
15.	117-168	1	ABRASION SLEEVE (1.00" x 80")	
16.	117-400	1	ABRASION SLEEVE (1.00" x 72")	
17.	354-583	1	FLOW DIVIDER BULKHEAD	
18.	105-622	2	BOLT (1/4-NC x 6")	
19.	105-085	2	LOCKNUT (1/4-NC)	
20.	117-684	1	ABRASION SLEEVE (1.00" x 26")	
21.	117-409	1	ABRASION SLEEVE (1.00" x 28")	
22.	154-278	1	CONNECTOR (04S-040)	

NOT SHOWN:

FOOTNOTES:

NOTE:

REFER TO O-RING CHART (800-301) IN BACK OF THE BOOK FOR REPLACEMENT OF O-RINGS.

# SHUTTLE STOP HYDRAULICS

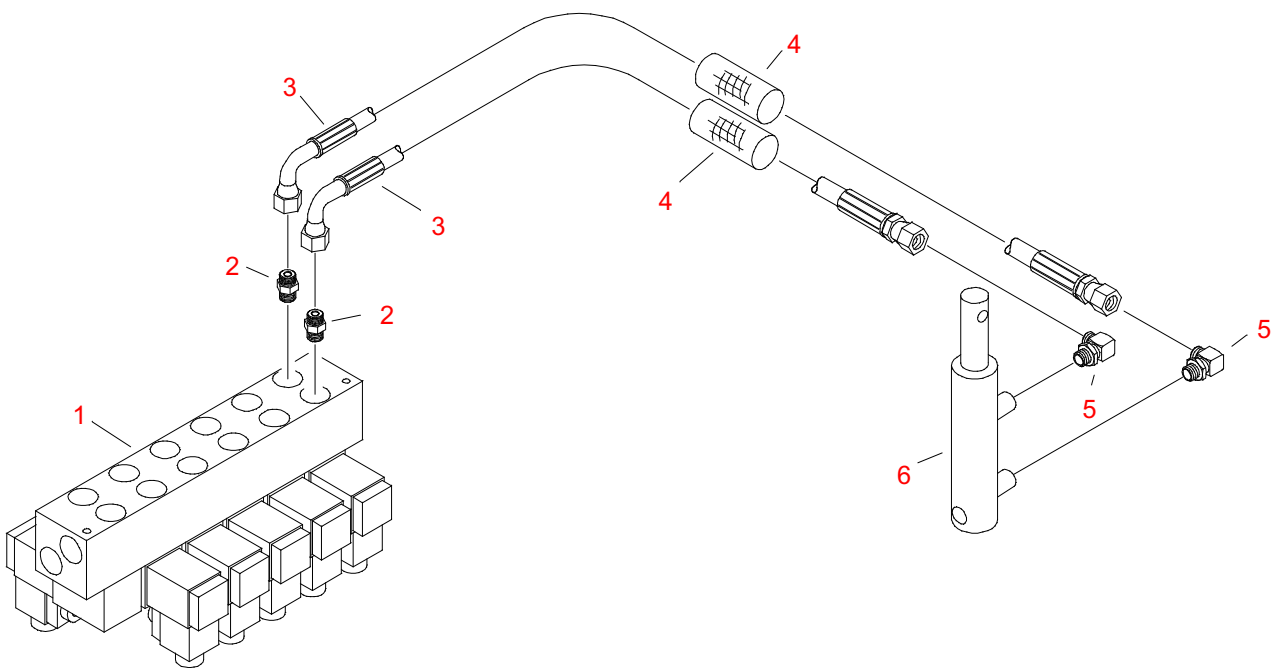

## SHUTTLE STOP HYDRAULICS

REF NO.	PART NUMBER	QTY	DESCRIPTION	REMARKS
1.	153-095	-	HYD VALVE	BEFORE S/N: CMWJT27T260000038 AFTER S/N: CMWJT27T260000039
	153-741	-	HYD VALVE	
2.	156-069	2	CONNECTOR (04S-040 ORF.040")	
3.	153-307	2	HOSE (040FX90S-38"-3000)	
4.	117-410	2	ABRASION SLEEVE (1.00" X 38")	
5.	154-401	2	CONNECTOR (04S-04090, ORF)	
6.	150-727	-	CYL (1.0" X .500" X 4.0")	

NOT SHOWN:

FOOTNOTES:

NOTE:

REFER TO O-RING CHART (800-301) IN BACK OF THE BOOK FOR REPLACEMENT OF O-RINGS.

## PROX SWITCHES

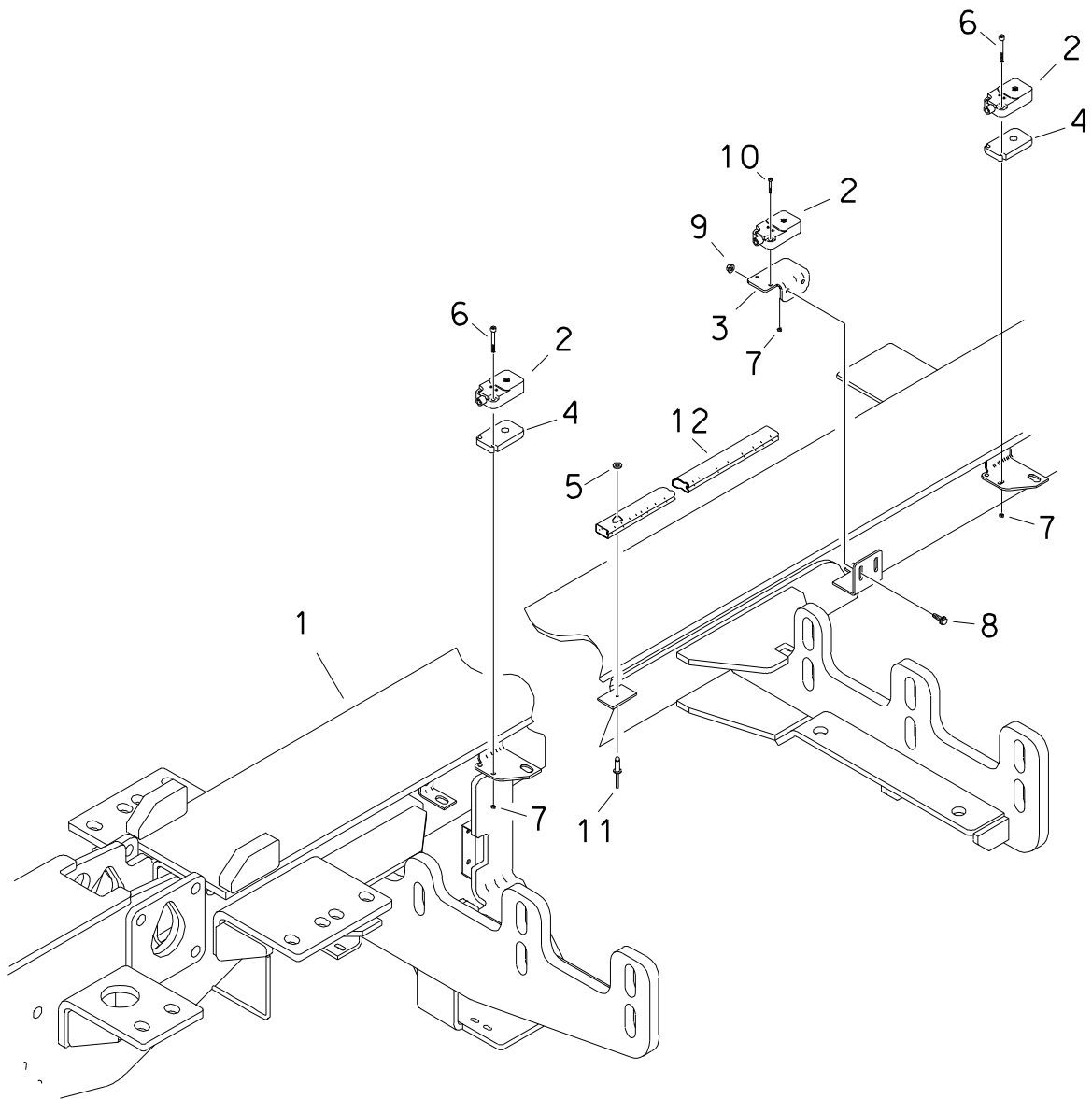

# PROX SWITCHES

REF NO.	PART NUMBER	QTY	DESCRIPTION	REMARKS
1.	303-648	-	DRILL FRAME	
2.	214-692	3	PROXIMITY SWITCH	
3.	305-732	1	BRACKET, PROXIMITY SWITCH	
4.	117-516	2	SHIM	
5.	106-832	2	WASHER (#4, SS)	
6.	107-667	4	SCRW (#10-24 X 1-1/2, SOC, GD5)	
7.	106-048	6	LOCKNUT (#10-24)	
8.	106-712	2	FLG SCREW (M6-1.00 X 16MM)	
9.	106-237	2	LOCKNUT (M6-1.00, PRV TRQ, NLK)	
10.	105-810	2	BOLT (#10-24 X 1/8", SOC)	
11.	107-134	2	POP RIVET (1/8" X 3/8")	
12.	310-357	1	WIRE CONDUIT	

NOT SHOWN  
 213-102 1 PULLBACK HARNESS FOOTNOTE 1

FOOTNOTES  
 1. FOR REARSTOP RETROFIT KIT ORDER PART # 599-302

# ELECTRICAL DIAGRAM PIPE LOADER HARNESS

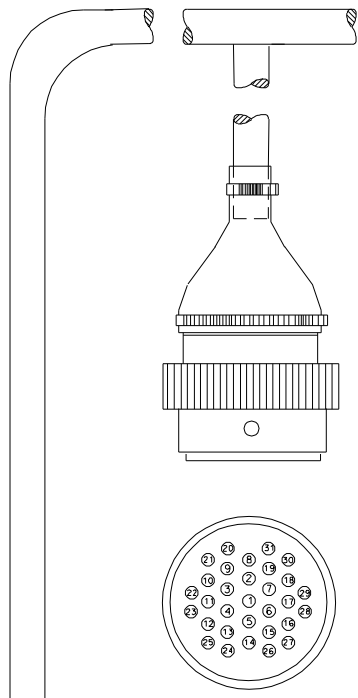
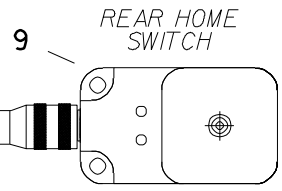

PIN*	PIN*	PIN*
1 BLU (12)	11 GRA/WHT (78)	21 BLK/RED (1A)
2 GRN/BLK (92)	12 PUR (118)	22 ORG (12)
3 TAN (117)	13 GRN (120)	23 BLK/BLU (18)
4 YEL/WHT (195)	14 RED/BLK (18)	24 PUR/WHT (192)
5 WHT (80)	15 BRN (123)	25 YEL (60)
6 TAN/RED (140)	16 BRN/WHT (194)	26 CAVITY PLUG
7 BLU/BLK (93)	17 PUR/WHT (100)	27 CAVITY PLUG
8 WHT/RED (79)	18 BLU/WHT (101)	28 CAVITY PLUG
9 GRA (119)	19 YEL (122)	29 CAVITY PLUG
10 BLK (1)	20 GRA/PUR (158)	30 CAVITY PLUG
		31 CAVITY PLUG

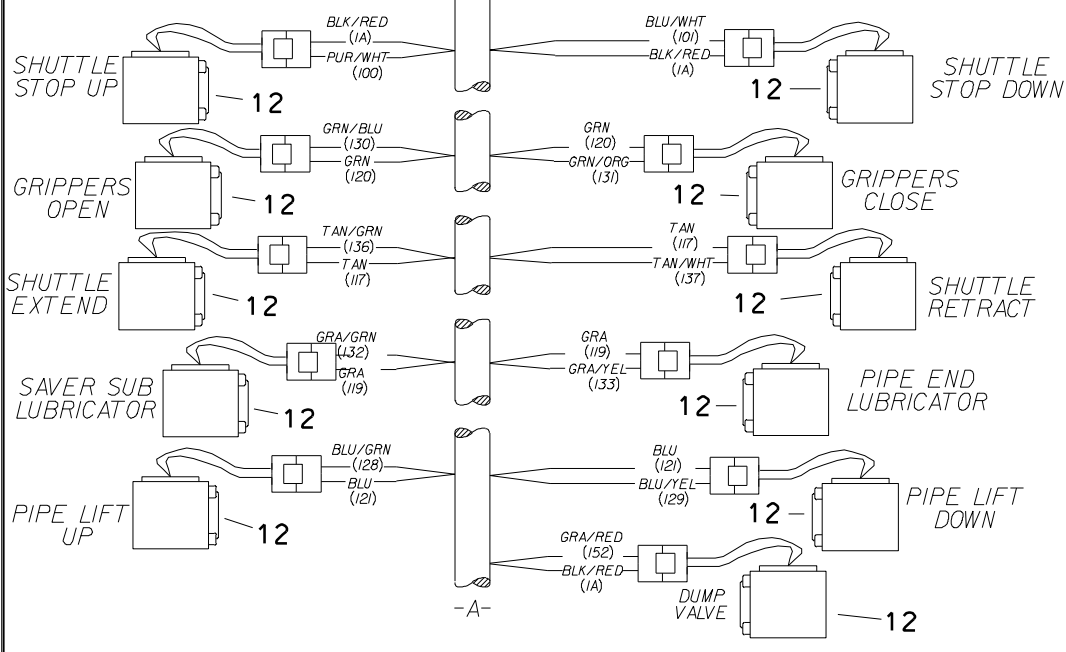

# ELECTRICAL DIAGRAM

## PIPE LOADER HARNESS

REF NO.	PART NUMBER	QTY	DESCRIPTION	REMARKS
1.	214-618	1	JT2720AT PIPELOADER	
2.	214-645	1	PRESSURE SWITCH (500PSI)	
3.	149-629	1	HOSE (06DRX-18"-3000, SPECIAL)	
4.	499-312	4	SOLENOID COIL	
5.	499-310	2	SOLENOID COIL	
6.	214-434	1	SOLENOID COIL (SMALL)	
7.	217-007	1	WORKING LIGHT (CLEAR, RECT)	
8.	214-697	1	GREEN STROBE LIGHT	
	217-297	1	STROBE LIGHT GREEN MED PROFILE	
	214-103	1	(2-WAY) MALE CONNECTOR	
	214-991	-	REPLACEMENT FLASH TUBE	
	157-645	2	WEATHER-PAC SEAL (2.80MM)	
	214-104	2	WEATHER-PAC SEAL (2.80MM)	
9.	214-692	3	PROXIMITY SWITCH	
10.	211-026	1	DIODE PACK (DEUTSCH)	
11.	211-025	1	IN-LINE DIODE PACK	
12.	499-305	11	SOLENOID COIL	
13.	214-781	1	12 WAY PLUG	

FOOTNOTES

# ELECTRICAL DIAGRAM PIPE LOADER HARNESS

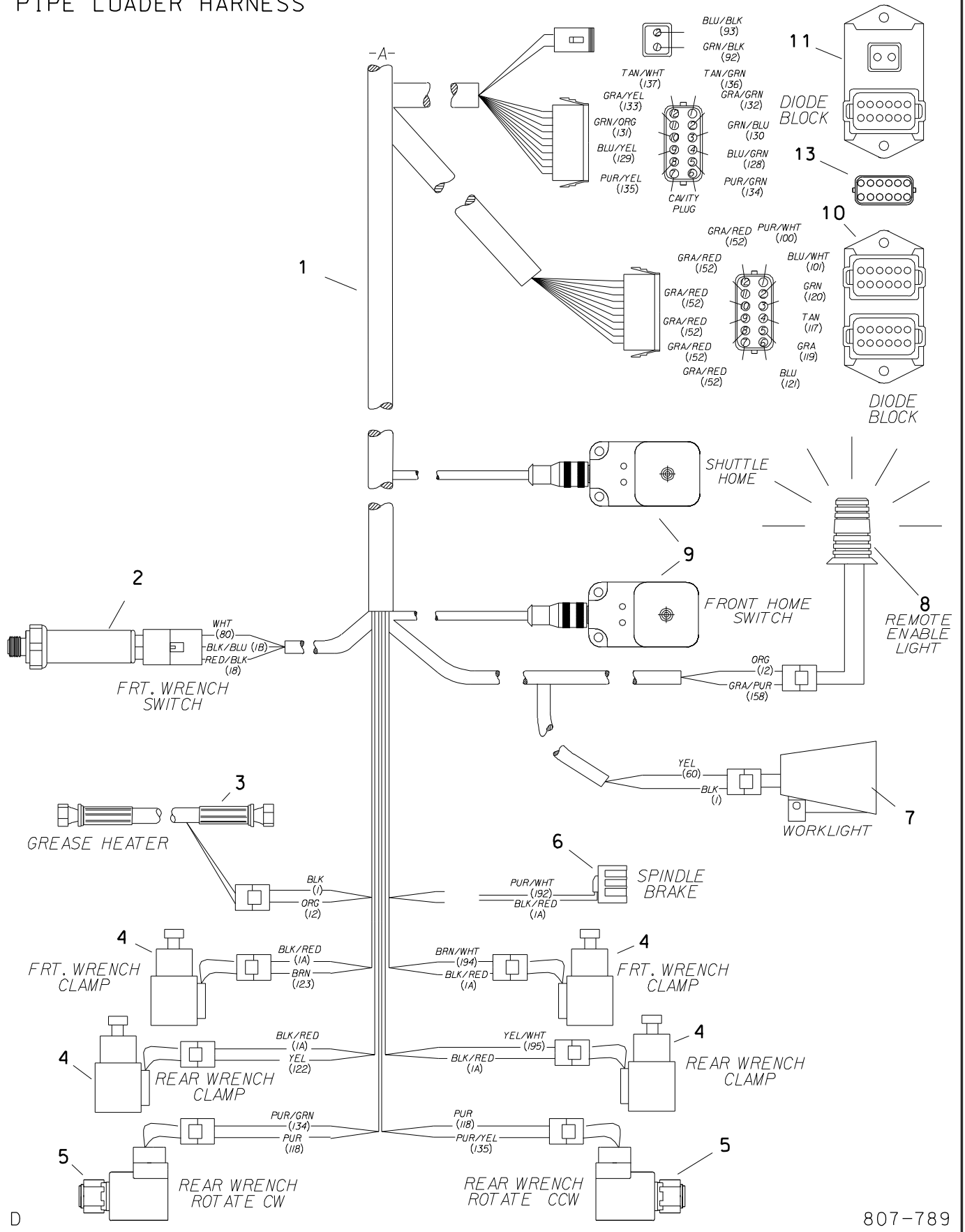

D



# ELECTRICAL DIAGRAM

## PULLBACK STOP HARNESS

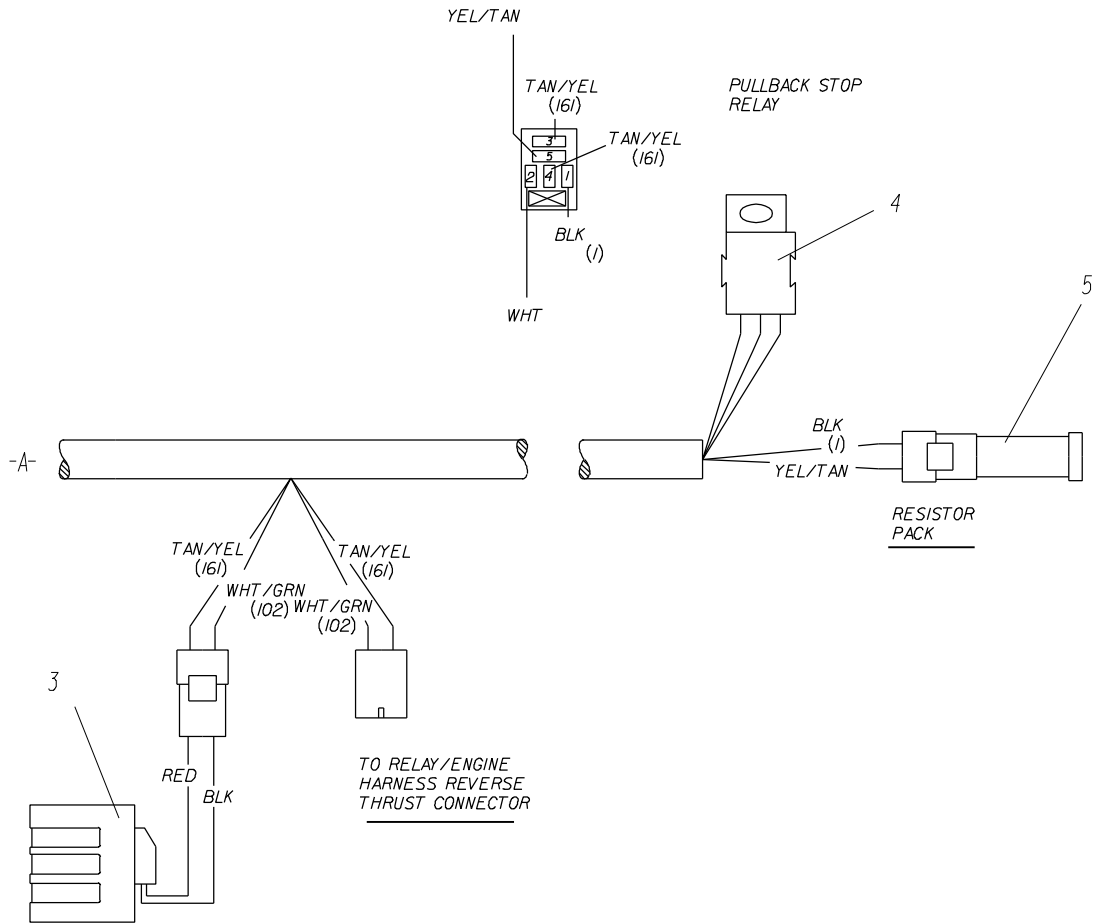

# ELECTRICAL DIAGRAM

## PULLBACK STOP HARNESS

REF. NO.	PART NUMBER	QTY.	DESCRIPTION
1.	214-692	1	PROXIMITY SWITCH
2.	213-102	1	AT/JT27M1 REAR STOP HARNESS
3.	214-434	1	SOLENOID COIL (SMALL)
4.	217-710	1	MICRO RELAY (SPDT)
5.	211-279	1	INNER ROTATION RESISTOR PACK

# ELECTRICAL DIAGRAM

## PULLBACK STOP HARNESS

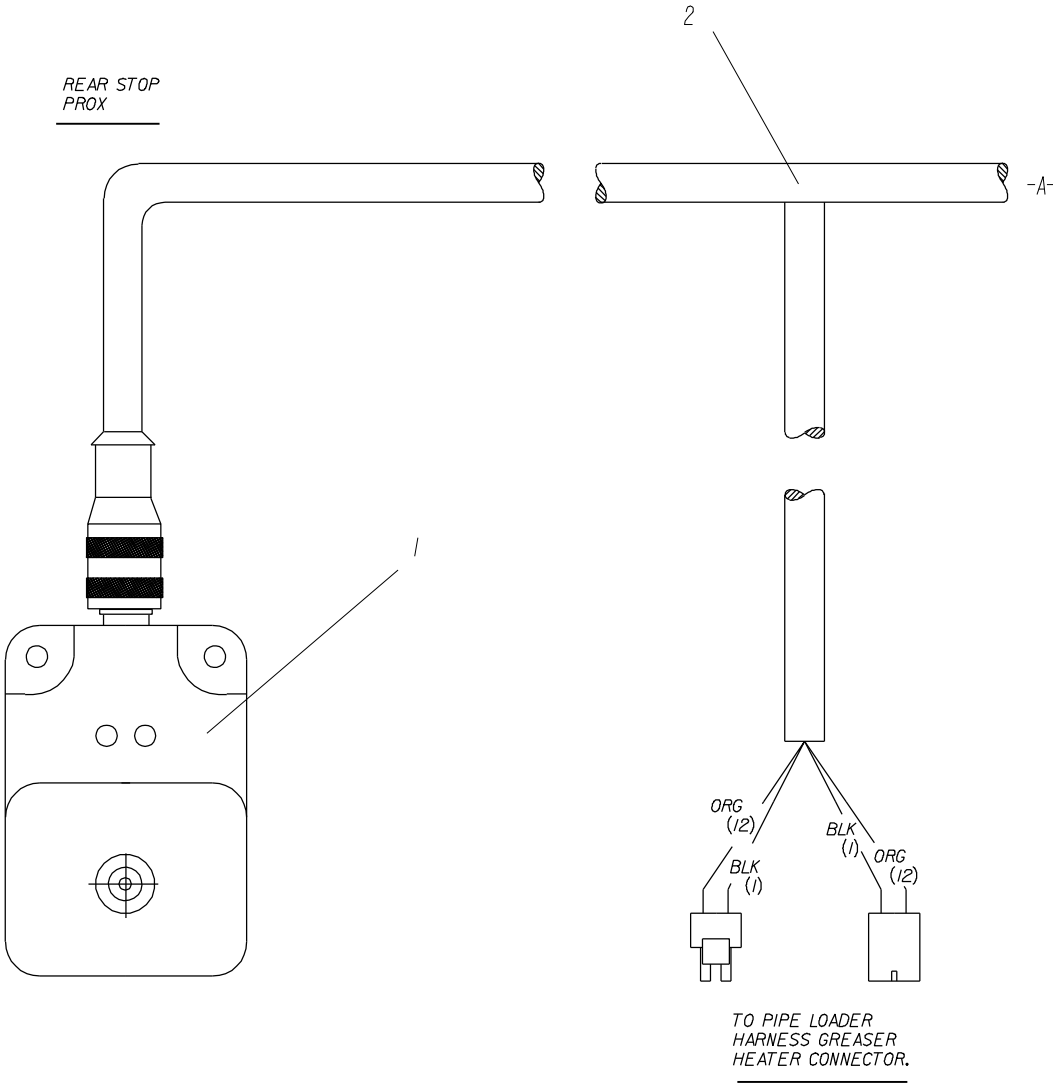



# **ACCESSORIES**

# FLUID MIXING ACCESSORIES

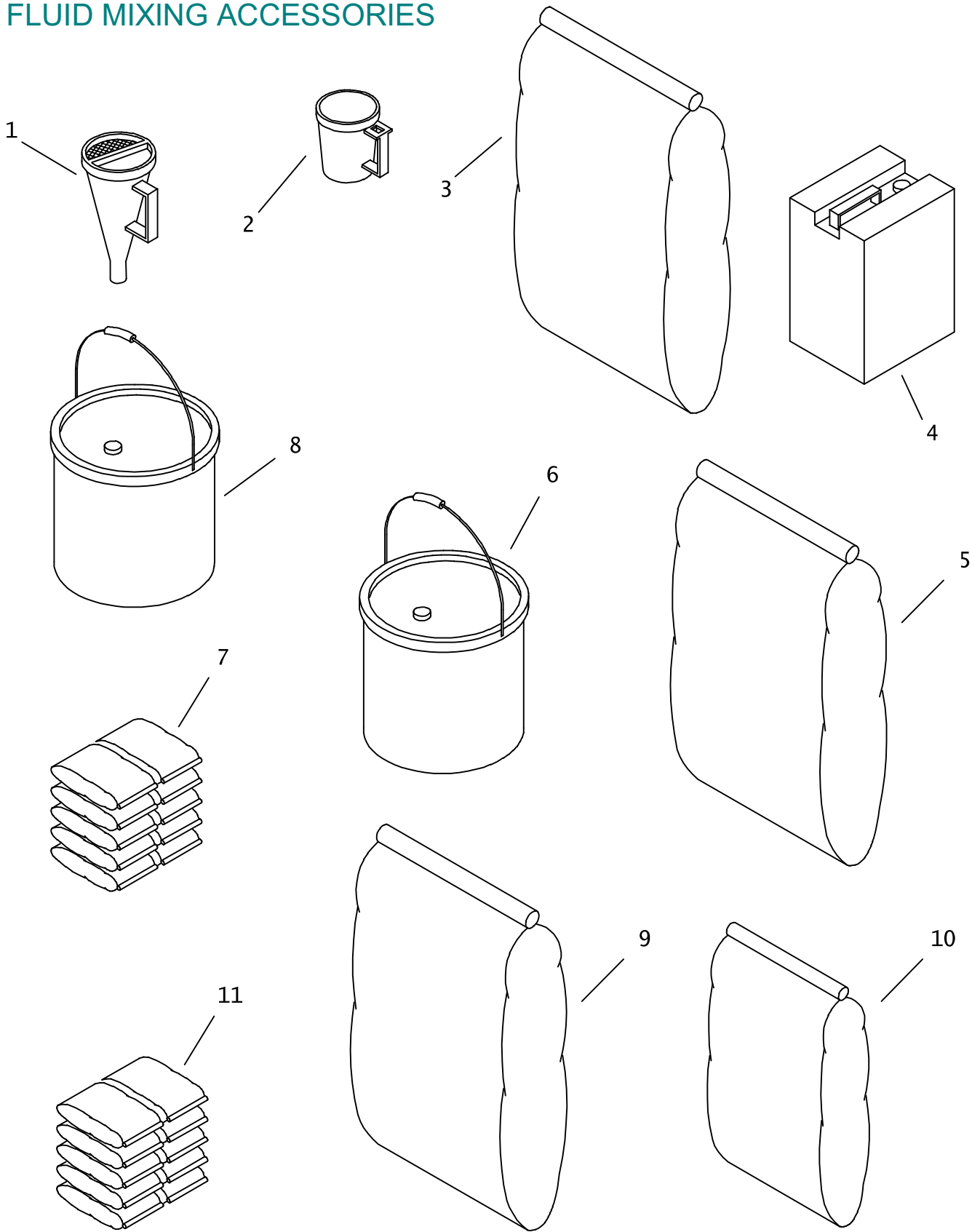

## FLUID MIXING ACCESSORIES

REF NO.	PART NUMBER	QTY	DESCRIPTION	REMARKS
1.	259-195	1	VISCOSITY FUNNEL	
2.	259-196	1	VISCOSITY CUP	
3.	259-804	AR	BENTONITE, QUIK-GEL (50 LB)	
4.	259-805	AR	LIQUID POLYMER, EZ-MUD (5 GAL)	
5.	259-807	AR	BENTONITE, BORE-GEL (50 LB)	
6.	259-808	AR	VISCOSIFIER, LIQUI-TROL (5 GAL)	
7.	259-809	AR	POWDER POLYMER, QUIK-TROL (20 LB)	
8.	259-810	AR	WET AGENT, CON-DET (5 GAL)	
9.	259-821	AR	'PAC-R' FILTRATION CONTROL	
10.	259-822	AR	'BARAZAN D+' VISCOSIFIER	
11.	259-832	AR	'NO SAG' (20# BOX/10-2#BAGS)	

NOT SHOWN:

191-158	1	DRILLING FLUID TEST KIT
259-487	1	SHEAROMETER

FOOTNOTES:

NOTE:

# WIRE LINE ASSEMBLY

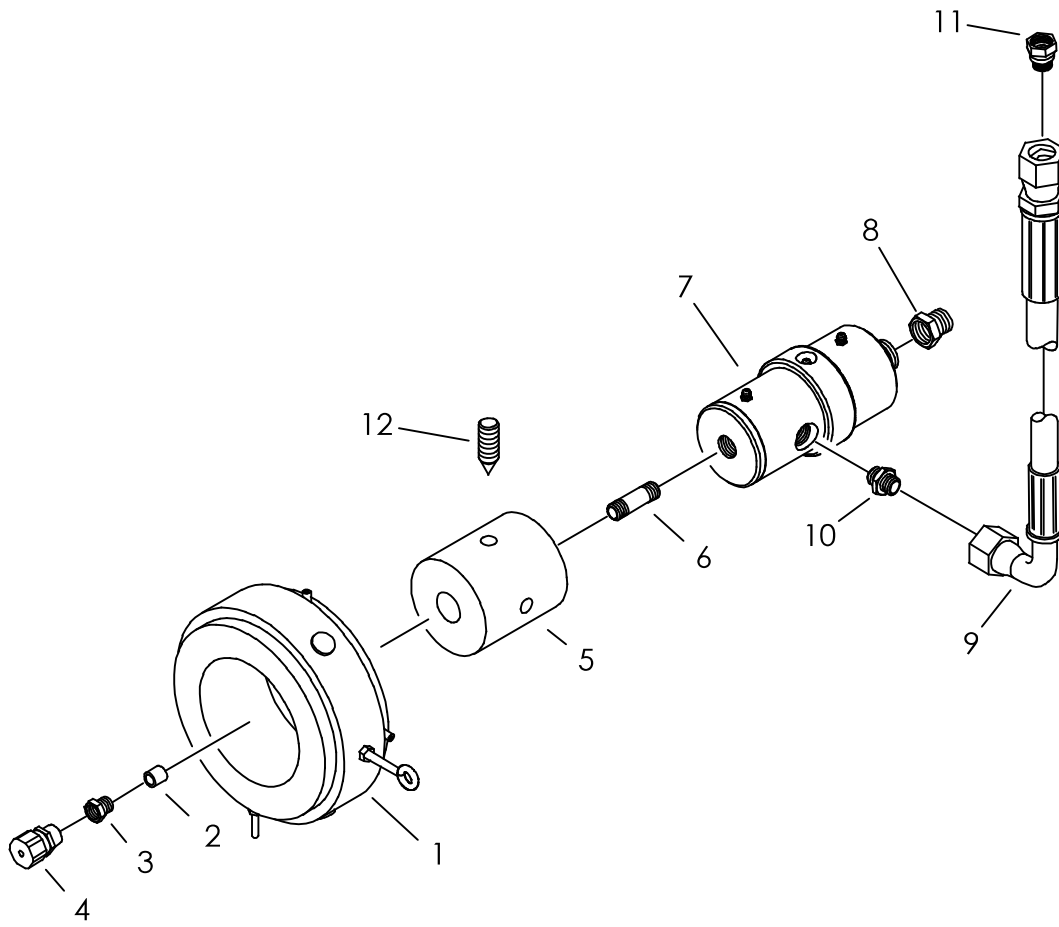



## WIRE LINE ASSEMBLY

REF NO.	PART NUMBER	QTY	DESCRIPTION	REMARKS
1.	358-860	1	COLLECTOR RING	
2.	115-155	1	COLLAR (08NF-08NF)	
3.	115-156	1	REDUCER (08N-06NF)	
4.	358-855	1	PACK-OFF FITTING (.125-.187)	
5.	306-980	1	ADAPTER, COLLECTOR RING	
6.	115-162	1	NIPPLE (08N-4")	
7.	159-288	1	WATER SWIVEL THRU SHAFT	
8.	115-151	1	REDUCER (16N-12NF)	
9.	154-867	1	HOSE (120FX90-36"-2250)	
10.	149-595	1	CONNECTOR (8N-120)	
11.	154-378	1	REDUCER STEM (120-160F)	
12.	105-707	4	SET SCREW (1/4-NF X3/8",CUP)	

NOT SHOWN:

FOOTNOTES:

NOTE:

# WORK LIGHTS

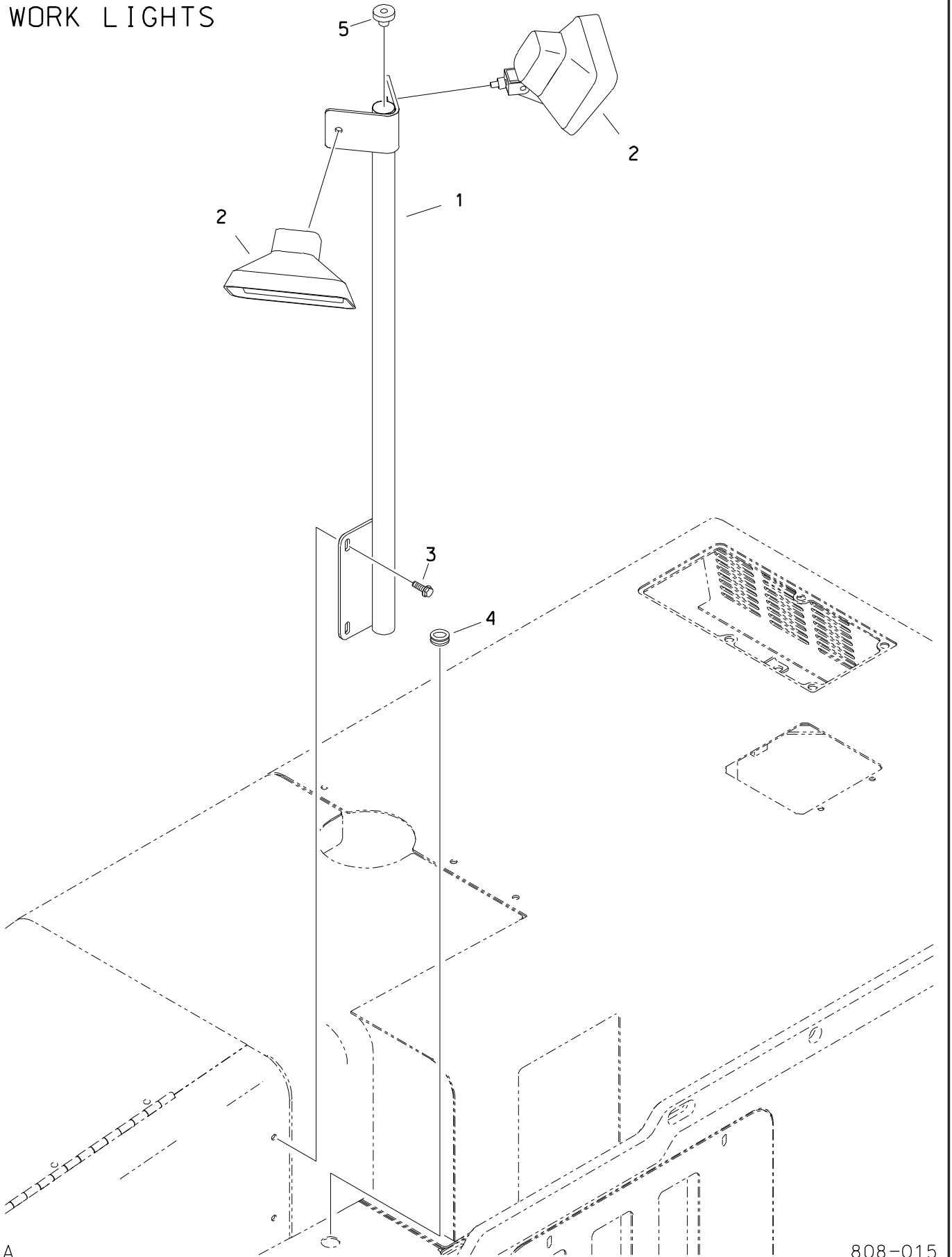

# WORK LIGHTS

REF NO.	PART NUMBER	QTY	DESCRIPTION	REMARKS
1.	305-924	1	SUPPORT, WORK LIGHT	
2.	217-057	2	WORKING LIGHT - CLEAR	
3.	106-991	-	FLG LK SCREW (M8-1.25 X 20MM)	
4.	502-001	1	GROMMET (3/8")	
5.	116-325	1	GROMMET (.362")	

FOOTNOTES

# HEATED HOSE KIT

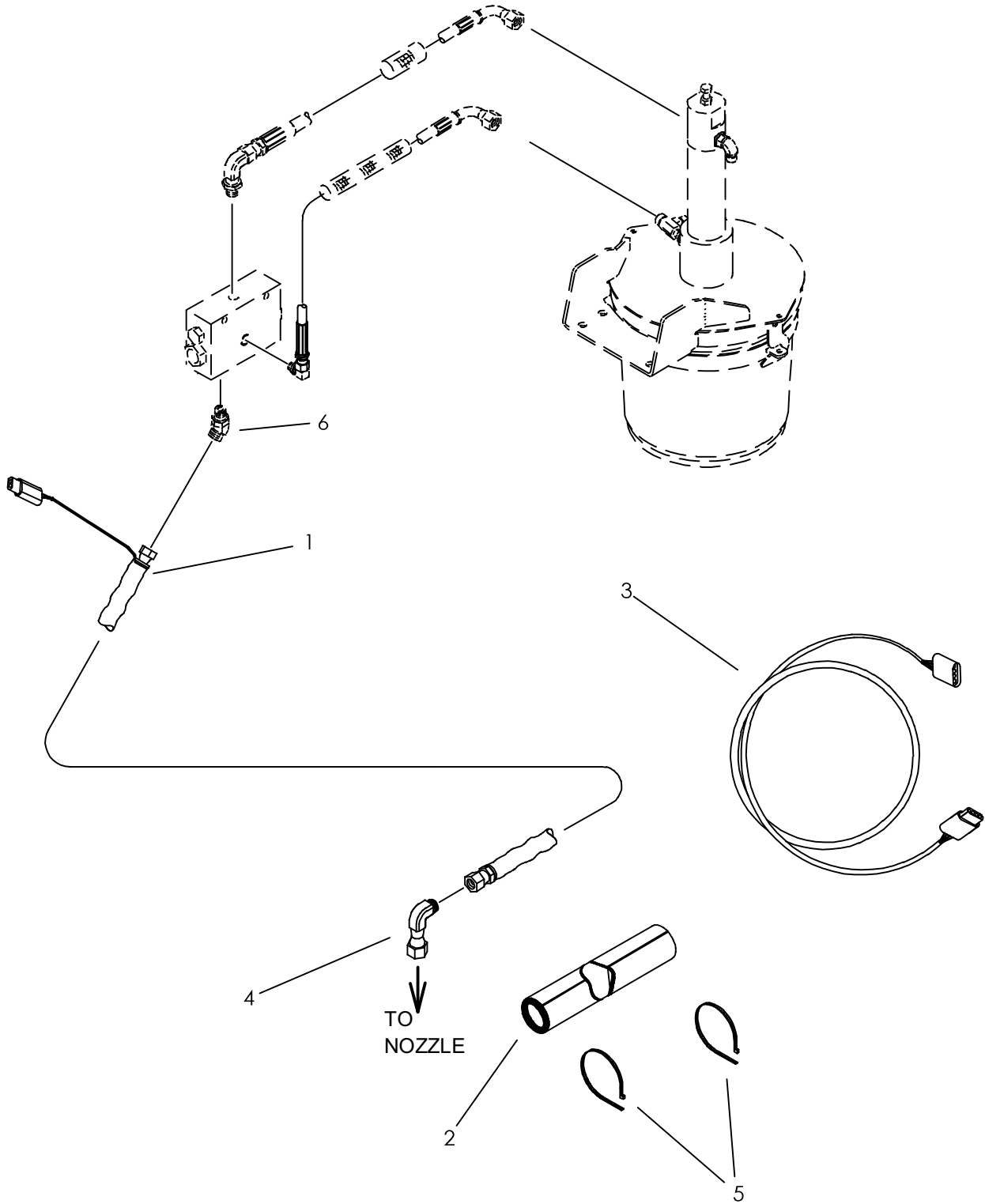

## HEATED HOSE KIT

REF NO.	PART NUMBER	QTY	DESCRIPTION	REMARKS
	101-088		JT27M1 HEATED HOSE KIT	USE REF.'S 1, 2, 3, & 5
	101-089		HEATED HOSE KIT	USE REF.'S 1, 2, 4, & 5
1.	153-585	1	HOSE (060FX-18"-3000,SPCL)	
2.	117-549	1	INSULATOR (1" ID X 5.00")	
3.	214-843	1	GREASER JUMPER HARNESS	USED ON JT2720 MACH 1 ONLY
4.	154-228	1	UNION (060-060FX90)	USED ON JT1720 MACH 1 & JT4020 MACH 1 ONLY
5.	110-030	4	CABLE TIE (1/16" TO 4")	
6.	154-224	1	CONNECTOR (06S-06045)	

NOT SHOWN:

FOOTNOTES:

NOTE:

REFERE TO INSTALLATION INSTRUCTION 05I-29I.

# DRILLING FLUID TRANSFER

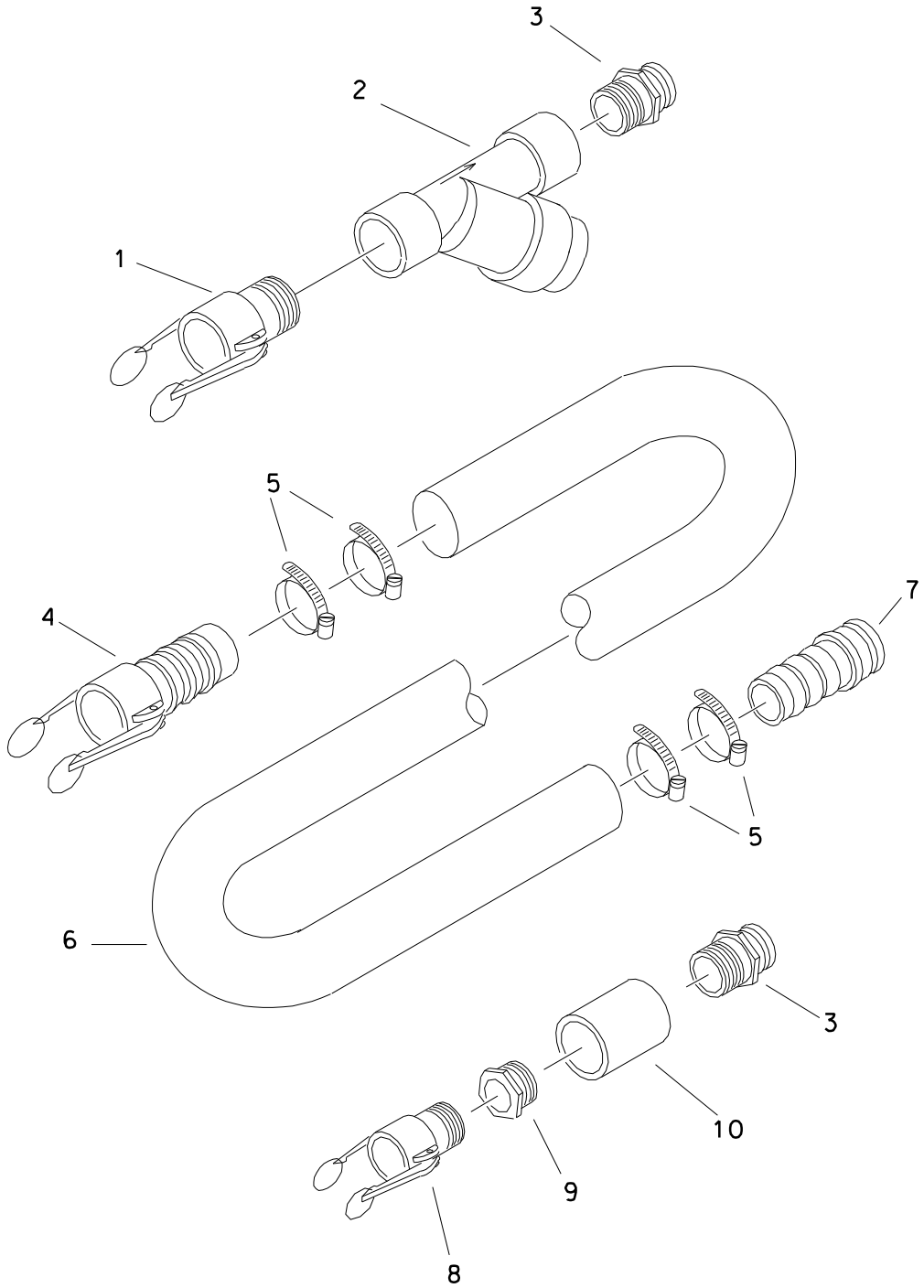

# DRILLING FLUID TRANSFER

REF NO.	PART NUMBER	QTY	DESCRIPTION	REMARKS
	343-273	-	Y-STRAINER PARTS ASS'Y	INCL REF NO'S 1 - 3
	149-919		TRANSFER HOSE ASSY HD 2" X 50'	INCL REF NO'S 4 - 7
	149-116		FHC PARTS (24-32N) ASS'Y	INCL REF NO'S 3, 8 - 10
1.	159-485	1	FHC BODY (32-32N)	
2.	159-176	1	Y-STRAINER (32NF)	
	159-239		STRAINER (2.2" X 7")	
3.	159-181	2	FHC ADAPTER (40-32N)	
4.	159-180	1	FHC BODY (40-32H)	
5.	110-134	4	WORM CLAMP (2-1/6" TO 2-3/4")	
6.	116-973	1	TRANSFER HOSE (50 FT)	
7.	149-119	1	FHC ADAPTER (32-32H)	
8.	159-500	1	FHC BODY (24-24N)	
9.	115-087	1	REDUCER (32N-24NF)	
10.	115-186	1	COLLAR (32NF)	

FOOTNOTES

PIPE BOX  
JT2720 MACH 1 ALL TERRAIN ONLY  
ENDS WITH S/N

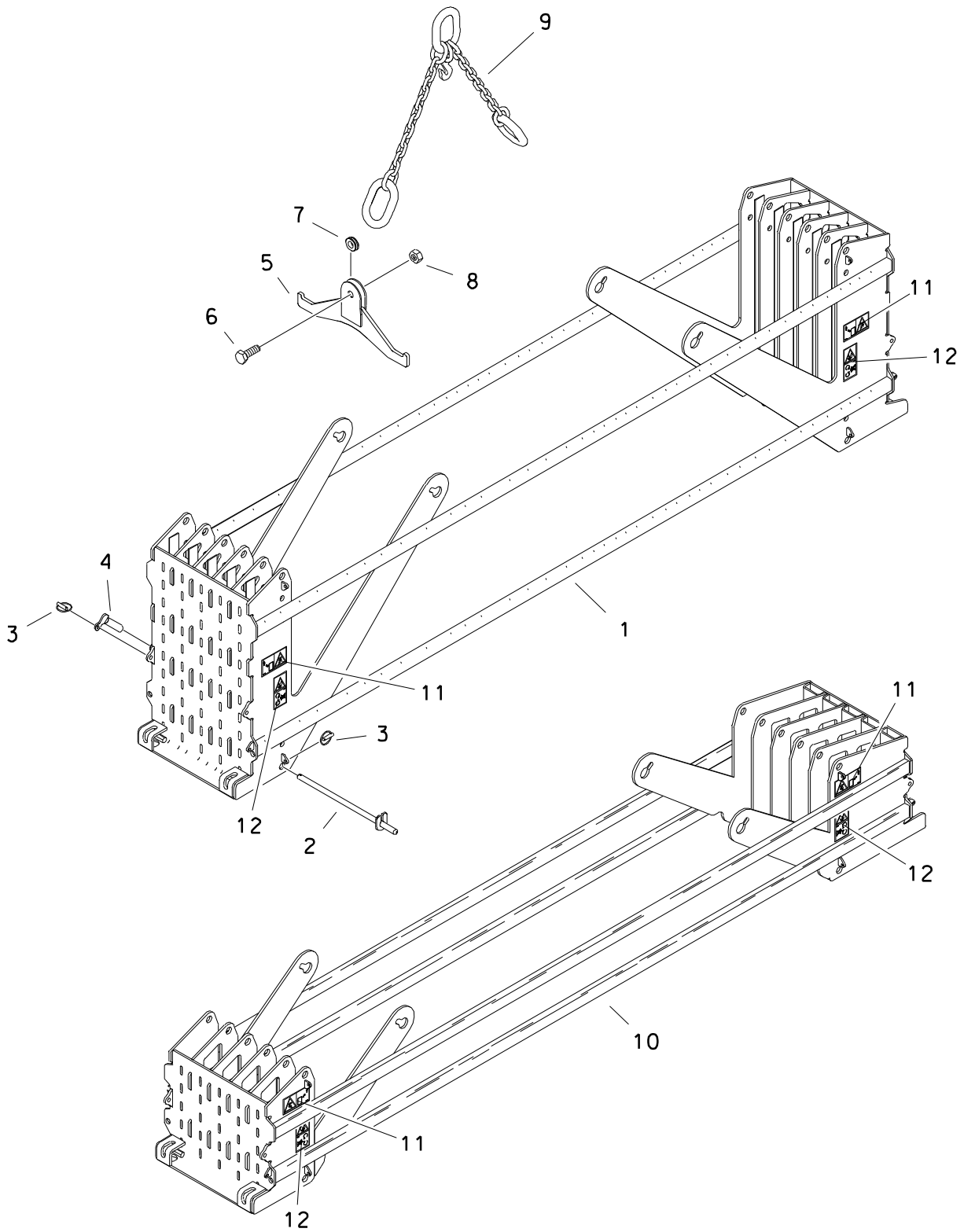



# PIPE BOX

JT2720 MACH 1 ALL TERRAIN ONLY  
 ENDS WITH S/N

REF NO.	PART NUMBER	QTY	DESCRIPTION	REMARKS
1.	303-629	1	PIPE LOADER BOX	
2.	303-876	4	PIPE BOX PIN WELDMENT	
3.	110-228	6	LYNCH PIN (7/16" X 2")	
4.	178-522	2	ROTATION PIN	
5.	308-318	2	SPREADER BAR	
6.	106-750	2	SCREW (M24-3.00 X 60MM)	
7.	178-449	2	SPACER	
8.	106-352	2	NUT (M24-3.00)	
9.	307-393	1	SLING CHAIN	
10.	310-740	1	SHORT PIPE BOX	
11.	701-326	4	WARNING CRUSHING WEIGHT	
12.	700-057	4	WARNING CRUSHING FORCE	

FOOTNOTES

# PIPE BOX

JT2720 MACH 1 ONLY

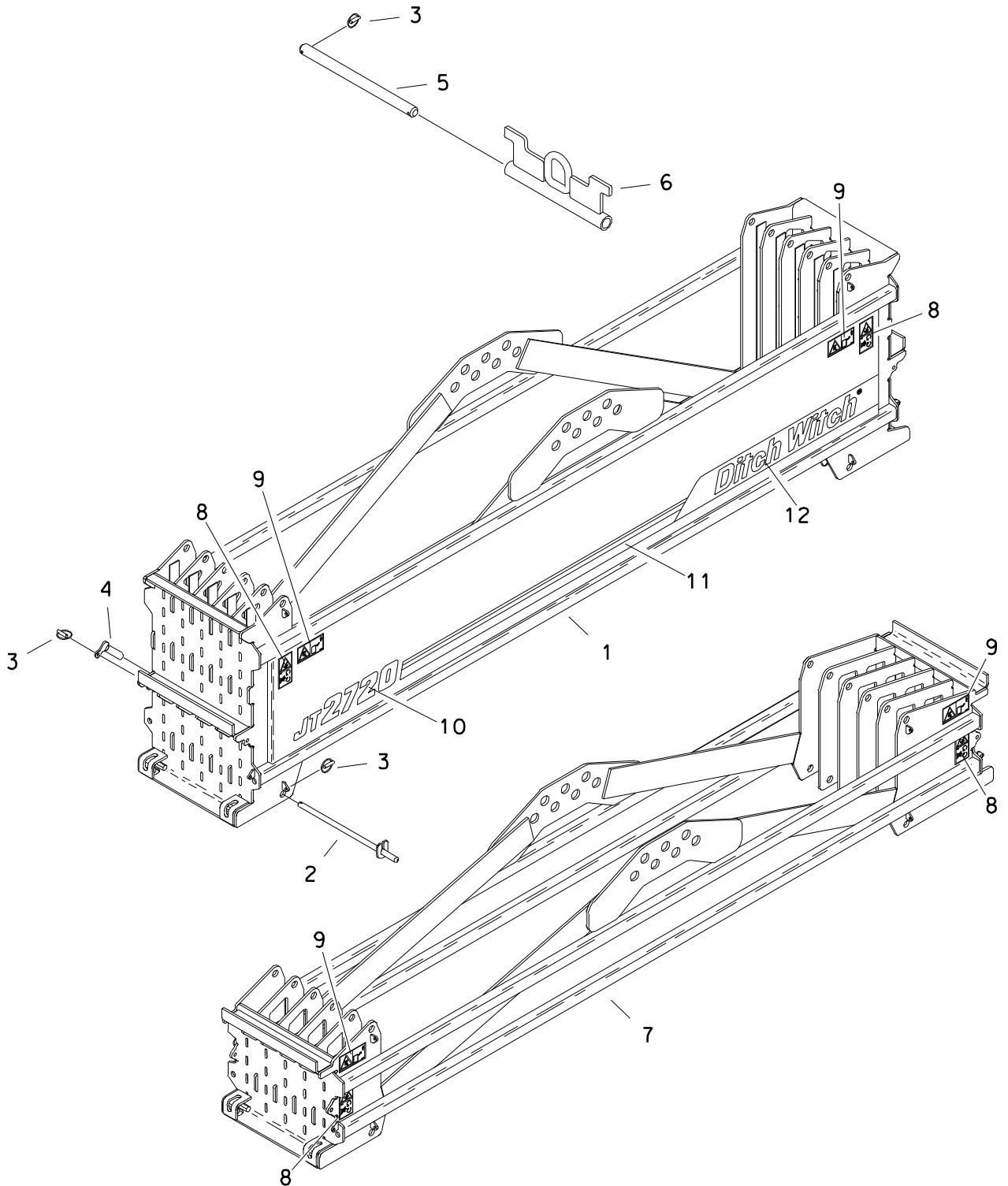

# PIPE BOX JT2720 MACH 1 ONLY

REF NO.	PART NUMBER	QTY	DESCRIPTION	REMARKS
1.	313-243	1	JT PIPE BOX	
2.	303-876	4	PIPE BOX PIN WELDMENT	
3.	110-228	8	LYNCH PIN (7/16" X 2")	
4.	178-522	2	ROTATION PIN	
5.	313-247	1	LIFT BAR	
6.	313-252	1	LIFT BLOCK	
7.	313-242	1	JT SHORT PIPE BOX	
8.	700-057	4	WARNING CRUSHING FORCE	
9.	701-326	4	WARNING CRUSHING WEIGHT	
10.	274-679	1	DECAL - MODEL ID {JT2720}	
11.	274-877	AR	GRAPHIC STRIPE	USE 1 @ 60.00"
12.	274-876	1	DITCH WITCH GRAPHIC STRIPE	

FOOTNOTES

# PIPE BOX

JT2720 MACH 1 ALL TERRAIN ONLY

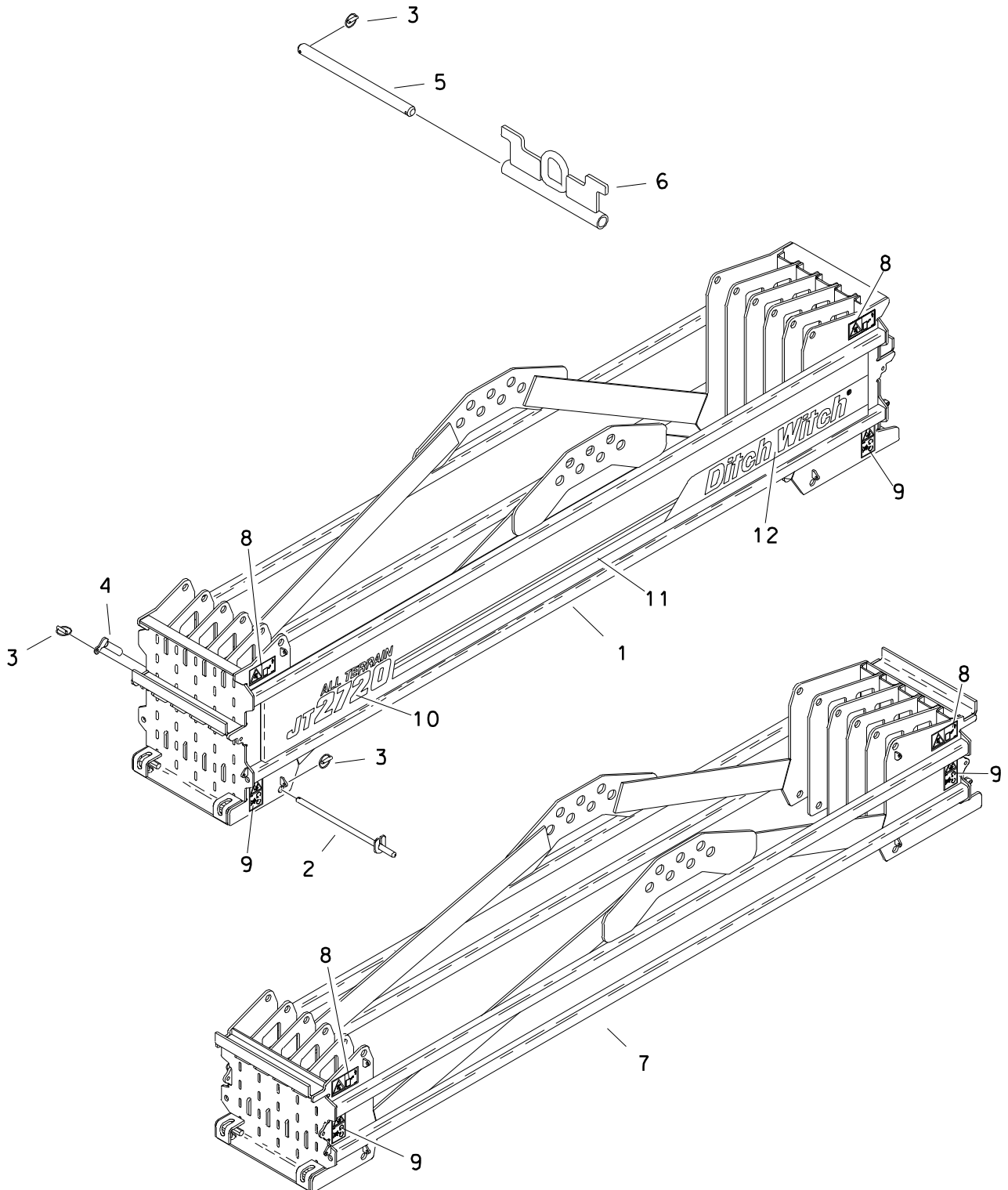

# PIPE BOX

## JT2720 MACH 1 ALL TERRAIN ONLY

REF NO.	PART NUMBER	QTY	DESCRIPTION	REMARKS
1.	313-240	1	AT PIPE BOX	
2.	303-876	4	PIPE BOX PIN WELDMENT	
3.	110-228	8	LYNCH PIN (7/16" X 2")	
4.	178-522	2	ROTATION PIN	
5.	313-247	1	LIFT BAR	
6.	313-252	1	LIFT BLOCK	
7.	313-241	1	AT SHORT PIPE BOX	
8.	701-326	4	WARNING CRUSHING WEIGHT	
9.	700-057	4	WARNING CRUSHING FORCE	
10.	273-187	1	JT2720 ALL-TERRAIN IDENTIFIER	
11.	274-877	AR	GRAPHIC STRIPE	USE 1 @ 50.47"
12.	274-876	1	DITCH WITCH GRAPHIC STRIPE	

FOOTNOTES

PIPE BOX  
JT2720 MACH 1 ONLY  
ENDS WITH S/N

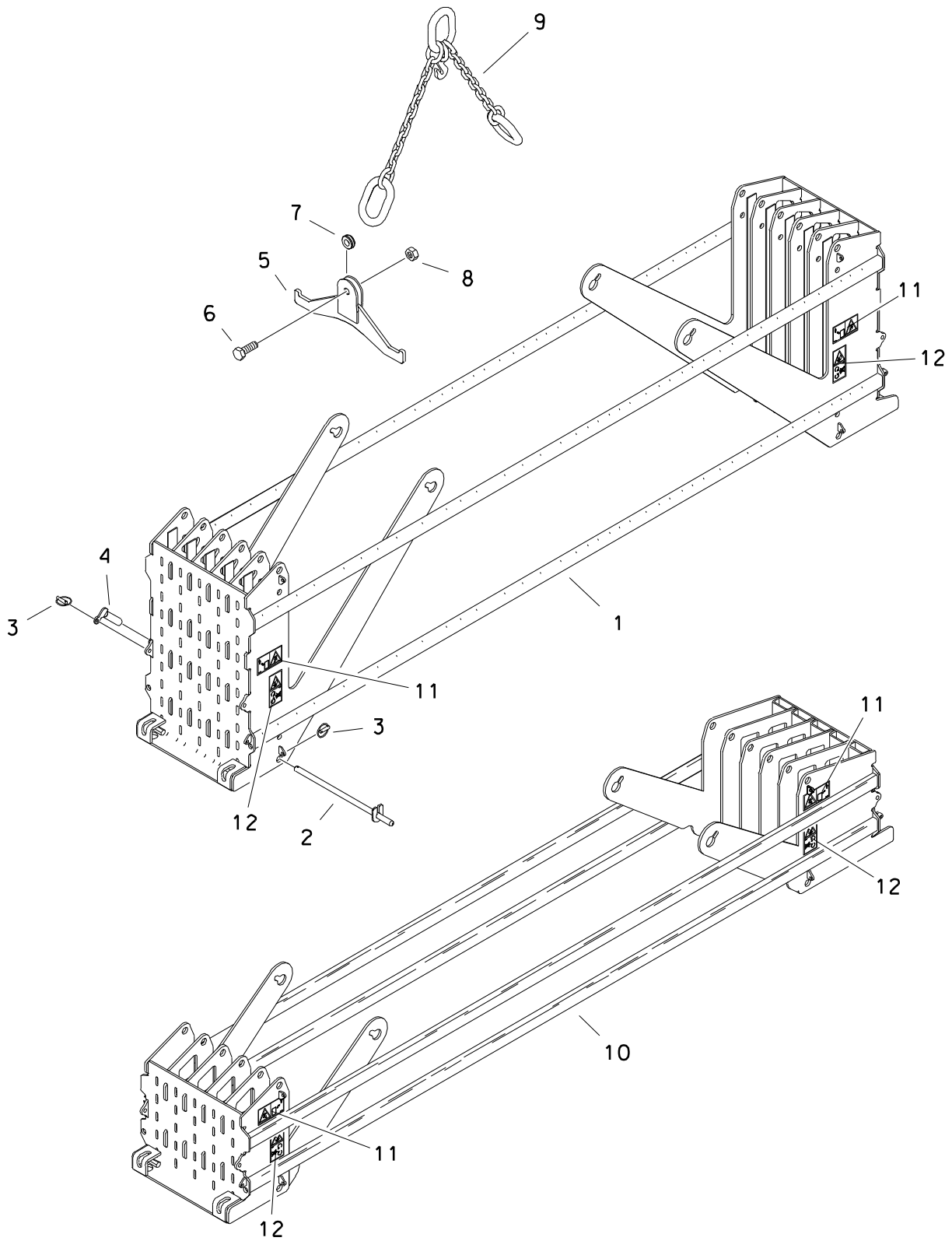

PIPE BOX  
 JT2720 MACH 1 ONLY  
 ENDS WITH S/N

REF NO.	PART NUMBER	QTY	DESCRIPTION	REMARKS
	191-083	-	PIPE BOX KIT {SHORT}	INCLUDES REF'S 2, 3, 4, 10
1.	303-717	1	PIPE BOX	
2.	303-876	4	PIPE BOX PIN	
3.	110-228	6	LYNCH PIN (7/16" X 2")	
4.	178-522	2	ROTATION PIN	
5.	308-318	2	SPREADER BAR	
6.	106-750	2	SCREW (M24-3.00 X 60MM)	
7.	178-449	2	SPACER	
8.	106-352	2	NUT (M24-3.00)	
9.	307-393	1	SLING CHAIN	
10.	309-720	1	PIPE LOADER BOX	
11.	701-326	4	WARNING CRUSHING WEIGHT	
12.	700-057	4	WARNING CRUSHING FORCE	

FOOTNOTES





# MISCELLANEOUS

## SAE Bolt and Nut Torque Value Chart

### Grade 5: UNC or UNF Thread

Size	Hex nut, or bolt tapped into hex nut, or d&t hole		Hex top deformed locknut		Flange nut, locknut, or bolt tapped into flange nut or d&t* hole	
	ft•lb	N•m	ft•lb	N•m	ft•lb	N•m
1/4	12	16	8	11	20	27
5/16	25	34	15	20	45	60
3/8	40	54	25	34	75	100
7/16	65	90	40	55	125	170
1/2	100	135	60	80	190	260
9/16	150	200	90	125	270	370
5/8	200	270	120	165	370	500
3/4	350	475	210	285	650	880
7/8	560	760	340	460	1250	1425
1	840	1140	500	680	1580	2145
1-1/8	1030	1400	320	840	1950	3645
1-1/4	1460	1980	880	1195	2760	3475

### Grade 8: UNC or UNF Thread

Size	Hex nut, or bolt tapped into hex nut, or d&t hole		Hex top deformed locknut		Flange nut, locknut, or bolt tapped into flange nut or d&t* hole	
	ft•lb	N•m	ft•lb	N•m	ft•lb	N•m
1/4	14	19	10	14	24	33
5/16	30	40	18	25	50	70
3/8	55	73	35	50	90	125
7/16	85	115	50	70	140	190
1/2	130	175	80	110	220	300
9/16	190	260	110	150	310	420
5/8	260	355	160	245	430	585
3/4	450	610	270	365	750	1015
7/8	730	990	440	600	1210	1640
1	1090	1480	650	880	1320	2465
1-1/8	1550	2100	930	1260	2580	3500
1-1/4	2180	2955	1310	1780	3640	4935

\*drilled and tapped

# Metric Bolt and Cap Screw Torque Values

Size	Class 4.8				Class 8.8 and 9.8				Class 10.9				Class 12.9			
	Lubricated		Dry		Lubricated		Dry		Lubricated		Dry		Lubricated		Dry	
	N•m	ft•lb	N•m	ft•lb	N•m	ft•lb	N•m	ft•lb	N•m	ft•lb	N•m	ft•lb	N•m	ft•lb	N•m	ft•lb
M6	4.8	3.5	6	4.5	9	6.5	11	8.5	13	9.5	17	12	15	11.5	19	14.5
M8	12	8.5	15	11	22	16	28	20	32	24	40	30	37	28	47	35
M10	23	17	29	21	43	32	55	40	63	47	80	60	75	55	95	70
M12	40	29	50	37	75	55	95	70	110	80	140	105	130	95	165	120
M14	63	47	80	60	120	88	150	110	175	130	225	165	205	150	260	190
M16	100	73	125	92	190	140	240	175	275	200	350	225	320	240	400	300
M18	135	100	175	125	260	195	330	250	375	275	475	350	440	325	560	410
M20	190	140	240	180	375	275	475	350	530	400	675	500	625	460	800	580
M22	260	190	330	250	510	375	650	475	725	540	925	675	850	625	1075	800
M24	330	250	425	310	650	475	825	600	925	675	1150	850	1075	800	1350	1000
M27	490	360	625	450	950	700	1200	875	1350	1000	1700	1250	1600	1150	2000	1500
M30	675	490	850	625	1600	950	1650	1200	1850	1350	2300	1700	2150	1600	2700	2000
M33	900	675	1150	850	1750	1300	2200	1650	2500	1850	3150	2350	2900	2150	3700	2750
M36	1150	850	1450	1075	2250	1650	2850	2100	3200	2350	4050	3000	3750	2750	4750	3500

Do not use these values if a different torque value or tightening procedure is given for specific application. Torque values listed are for general use only. Check tightness of fasteners periodically.

Shear bolts are designed to fail under predetermined loads. Always replace shear bolts with identical property class fasteners.

Fasteners should be replaced with the same or higher property class. If higher property class fasteners are used, these should only be tightened to strength of original.

Make sure fastener threads are clean and that the threads are properly started. This will prevent them from cross threading or galling when tightened.

Tighten plastic insert or crimped type steel locknuts to approximately 50% of dry torque indicated on chart. Apply torque to the nut - not the bolt head. Tighten toothed or serrated type locknuts to full torque value.

LUBRICATED means coated with lubricant. DRY means plain or zinc plated without any type of lubricant.

## Hydraulic Cylinder Bolt Torque Chart

Bolt Size (inch)	Bolt Part No.	Cylinder Repair Kit Part No.	Torque (ft•lb)	Torque (N•m)
1/2	106-096	190-165	90-100	120-135
5/8	106-097	190-166 & 190-169	180-200	245-270
3/4	106-098	190-167 & 190-170	290-325	395-440
7/8	106-122	190-172 & 190-174	410-640	550-625
1	106-145	190-175 & 190-189	630-700	855-950
1-1/8	106-146	190-177	770-850	1045-1170

As a general rule:

- 1/2-inch bolts are used in cylinders with 1-inch rods
- 5/8-inch bolts are used in cylinders with 1 1/4-inch rods
- 3/4-inch bolts are used in cylinders with 1 1/2-inch rods
- 7/8-inch bolts are used in cylinders with 1 3/4-inch rods
- 1-inch bolts are used in cylinders with 2-inch rods (one with 1 3/4-inch)
- 1-1/8-inch bolts are used in cylinders with 2-1/4-inch rods

**IMPORTANT:** Do not reuse cylinder piston bolts when rebuilding a hydraulic cylinder. Each cylinder repair kit contains a new bolt. Use it. Lubricate lightly and torque to value shown on chart.

# SAE & ORS Hydraulic Fitting Replacement O-Ring Chart

Fraction Size	Dash Size	SAE (Port Seal O-Ring)		ORS (Face Seal O-Ring)	
		Thread Size	O-Ring P/N	Thread Size	O-Ring P/N
1/16	1	NA	NA	NA	NA
1/8	2	5/16 - 24	NA	NA	NA
3/16	3	3/8 - 24	NA	NA	NA
1/4	4	7/16 - 20	155-760	9/16 - 18	157-037
5/16	5	1/2 - 20	NA	NA	NA
3/8	6	9/16 - 18	155-705	11/16 - 16	157-038
1/2	8	3/4 - 16	155-706	13/16 - 16	157-039
5/8	10	7/8 - 14	155-707	1 - 14	157-040
3/4	12	1-1/16 - 12	155-709	1-3/16 - 12	157-017
7/8	14	1-3/16 - 12	155-747	NA	NA
1	16	1-5/16 - 12	155-748	1-7/16 - 12	155-714
1-1/4	20	1-5/8 - 12	155-702	1-11/16 - 12	NA
1-1/2	24	1-7/8 - 12	157-001	2 - 12	NA
2	32	2-1/2 - 12	NA	NA	NA
2-1/2	40	3 - 12	NA	NA	NA
3	48	3-1/2 - 12	NA	NA	NA

Thread size indicates the diameter of the threaded area in fractions of an inch and number of threads per inch.

NA = not a current CMW part numbered o-ring, or dash size does not occur in current CMW applications

SAE = straight thread fitting that seals by sandwiching a hard o-ring between a shoulder on the male part and an angular surface at the mouth of the female port.

ORS = o-ring face seal; a type of fitting that seals by compressing a hard, captive o-ring between two flat parallel faces, one grooved for the o-ring and the other plain to act as the sealing surface

# AT/JT2720 Mach 1

## Related Publications

Component	Ass'y	P/N
<b>Model:</b>		
<b>JT2720 Mach 1</b>		
JT2720 Mach 1 ..... Parts Manual .....		053-081
JT2720 Mach 1 ..... Operators Manual .....		054-063
JT2720 Mach 1 ..... Repair Guide (Service Manual) .....		N/A
JT2720 Mach 1 ..... Supplementary Maint Guide - Trenchless .....		055-485
JT2720 Mach 1 ..... Special Tools Guide .....		052-901
<b>All Terrain</b>		
AT2720 Mach 1 ..... Parts Manual .....		053-081
AT2720 Mach 1 ..... Operators Manual .....		054-063
AT2720 Mach 1 ..... Repair Guide (Service Manual) .....		N/A
AT2720 Mach 1 ..... Supplementary Maint Guide - Trenchless .....		055-485
AT2720 Mach 1 ..... Special Tools Guide .....		052-901
<b>Engine:</b>		
John Deere ..... Parts Manual - 4045TF150 .....	194-020	053-059
John Deere ..... Operators Manual - 4045TF150 .....		054-049
John Deere ..... Service (Shop) Manual - 4045TF150 .....		054-049

## Filters

<b>Engine:</b>		
Air Filter Parts Ass'y .....		120-081
Element (primary) .....		194-830
Oil Filter Element (spin-on) - John Deere (4045TF150) .....		194-815
Fuel Filter Element (spin-on) - John Deere (4045TF150) .....		159-231
Fuel Strainer (04H) .....		156-268
Fuel Filter Element (water trap, clamp-on) - 3.75" x 5.00" x 3.12" .....		159-009
Element (water trap, clamp-on) - 3.75" x 5.00" x 3.25", Early Style .....		159-111
<b>Hydraulic:</b>		
Oil Filter Element (1-1/2-UNF, spin-on, Replacement) .....		159-079 **
Element (1-1/2-UNF, spin-on, Break-In) .....		149-840
Element (2-UNF, spin-on) .....		149-939 **
<b>Water {H2O}:</b>		
Water Strainer (2.250" x 7.0") - Y-Strainer .....		159-239

## Optional Kits

O-ring Repair Kit - FLG, ORS & SAE (15 different O-rings) .....	190-051
O-ring Repair Kit - Field Service (46 different O-rings) .....	190-052



**Ditch  
Witch**

# Parts Manual Change Request

(Please print clearly)

Date: \_\_\_\_\_ Dealer No. (required): \_\_\_\_\_

Your Name: \_\_\_\_\_ Position: \_\_\_\_\_

Phone: \_\_\_\_\_ Fax: \_\_\_\_\_ E-mail: \_\_\_\_\_

## Publication Information:

Parts Manual No.: \_\_\_\_\_ - \_\_\_\_\_ Model: \_\_\_\_\_

Illustration Part No.:	Manual Page No.:
1. _____ - _____ .....	1. _____
2. _____ - _____ .....	2. _____
3. _____ - _____ .....	3. _____

Nature of Change Request:

- Text
- Graphics
- Missing Information

Describe change requested (if possible, include copy of publication page with changes marked.):

---



---



---



---



---



---

**Please fax completed form to  
Parts Manual Department (580) 572-3525**

*Thank you for taking the time to submit this request. We will contact you if further information is needed to process your request.*





**A Note To  
Ditch Witch  
Equipment Owners:**

If your equipment was purchased through a Ditch Witch dealer, there is no need to read further.

However, if you purchased from any other source, please fill out the form on the reverse side and return it to us.

This will enable you to receive updates on this equipment as well as information on new products of interest.

Thanks for using Ditch Witch equipment.

(Please Fold Along This Line And Seal At Bottom With Tape)

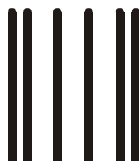

**NO POSTAGE  
NECESSARY  
IF MAILED  
IN THE  
UNITED STATES**

**BUSINESS REPLY MAIL**  
FIRST CLASS      PERMIT NO 23      PERRY OKLAHOMA

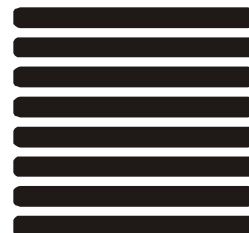

POSTAGE WILL BE PAID BY

**The Charles Machine Works, Inc.  
P.O. Box 66  
Perry, Oklahoma 73077-9989**



# Ditch Witch® Registration Card

Please Type or Print All Information

---

Purchaser's Company Name

---

Attention

---

Street Address or P.O. Box

---

City

County

---

State

Zip

Nation

(      )

---

Phone Number With Area Code

---

Model

Serial Number

---

Attachments/Accessories

Serial Numbers

---

Attachments/Accessories

Serial Numbers

---

Attachments/Accessories

Serial Numbers

---

Name of Ditch Witch Dealership

---

Your Signature